

536634
Factory Simulation 24V

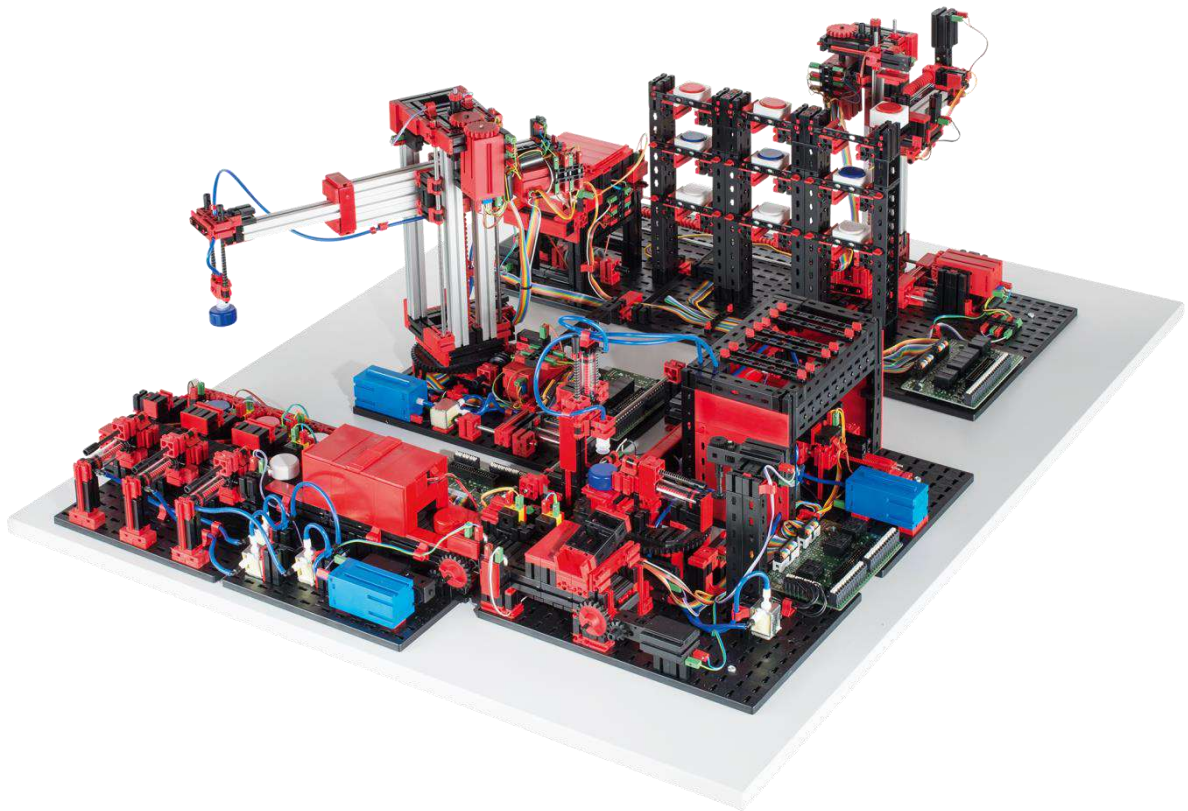

Contents

- Introduction..... 2
- First Steps 2
- Circuit layout for the Factory Simulation 24V 3
 - Circuit layout for Vacuum Gripper Robot 24V 3
 - Circuit layout for Automated High-Bay Warehouse 24V 4
 - Circuit layout for Multi Processing Station with Oven 24V 5
 - Circuit layout for Sorting Line with Detection 24V..... 6
- PLC input and output configuration 7
- Component description..... 8
- Models..... 12
 - Vacuum gripper robot (VSG) 12
 - Automated high-bay warehouse (HRL) 22
 - Multi processing station with oven 30
 - Sorting line with detection 35

Introduction

Factory simulation from fischertechnik is a training model, consisting of fischertechnik modules, which simulate a small factory. This consists of several individual models, such as the "automated high-bay warehouse", a "multi processing station with oven", a "vacuum gripper robot" and a "sorting line with detection". By linking several stations the processes can illustrate a machining line.

The model has four 24 Volt printed circuit boards and can be controlled via any conventional PLC. This way you can create a completely unique program and with the aid of the assignment plan directly control the inputs and outputs. However, the individual programs must be matched to each other, so that it does not lead to a collision.

The process of the following sequence is provided through the structure of the model. The vacuum gripper robot loads the rack feeder of the automated high-bay warehouse with workpieces. This stores the workpieces in the high-bay warehouse, sorted according to color. Finally, the workpieces are taken out of storage again, brought to the multi processing station and machined there. After this the machined workpieces are sorted in the sorting line according to color and conveyed into storage locations. From there the workpieces are picked up again by the vacuum gripper robot and transported back to the high-bay warehouse.

First Steps

After you have unpacked the "Factory Simulation" and removed the transport locks, perform a visual inspection to see whether components have come loose or been damaged during transport. If necessary, put loose components back in the correct place. Compare your model with the comparison pictures of the "Factory simulation", which is stored on the eLearning portal. Check whether all cables and hoses are connected. Using the assignment plan, the unconnected cable can be connected correctly.

Now insert the workpiece carrier in the high-bay warehouse, making sure that the recesses are pointed forwards (cf. Figure 1). Place the workpieces in the provided storage locations at the sorting line (cf. Figure 2).

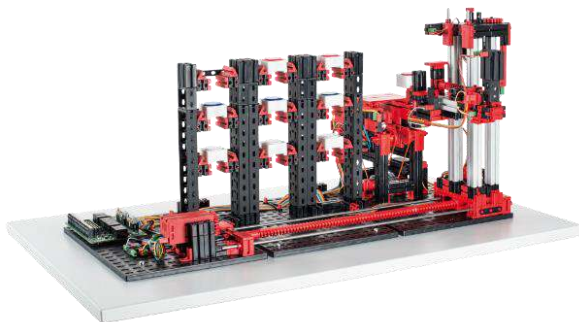

Figure 1: Workpiece carrier in high-bay warehouse

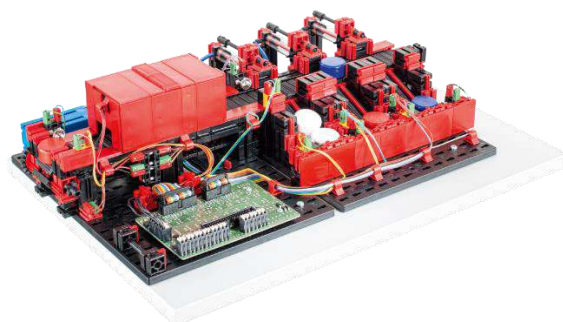
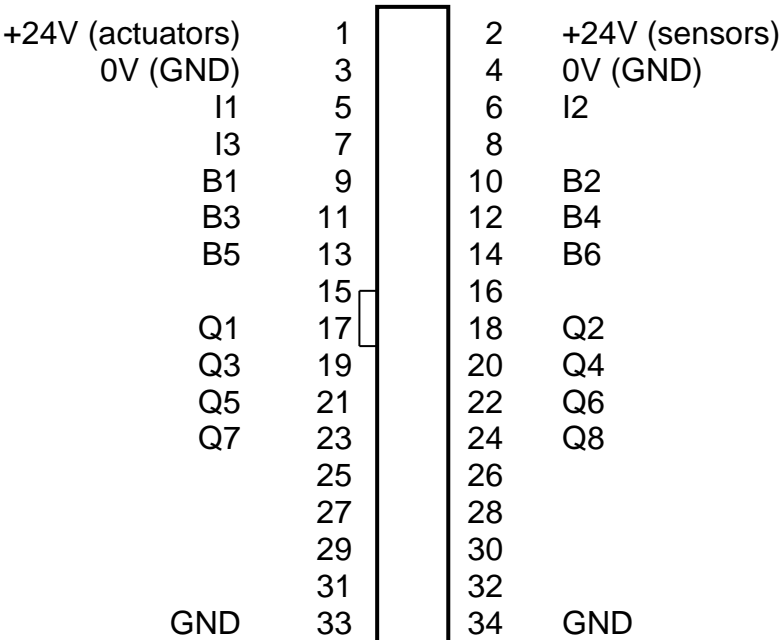

Figure 2: Workpieces in the storage locations

Circuit layout for the Factory Simulation 24V

Circuit layout for Vacuum Gripper Robot 24V

Terminal no.	Function	Input/Output
1	power supply (+) actuators	24V DC
2	power supply (+) sensors	24V DC
3	power supply (-)	0V
4	power supply (-)	0V
5	reference switch vertical axis	I1
6	reference switch horizontal axis	I2
7	reference switch rotate	I3
8	Not used	
9	encoder vertical axis impulse 1	B1
10	encoder vertical axis impulse 2	B2
11	encoder horizontal axis impulse 1	B3
12	encoder horizontal axis impulse 2	B4
13	encoder rotate impulse 1	B5
14	encoder rotate impulse 2	B6
17	motor vertical axis up	Q1 (M1)
18	motor vertical axis down	Q2 (M1)
19	motor horizontal axis backward	Q3 (M2)
20	motor horizontal axis forward	Q4 (M2)
21	motor rotate clockwise	Q5 (M3)
22	motor rotate counterclockwise	Q6(M3)
23	Compressor	Q7
24	Valve vacuum	Q8



Circuit layout for Automated High-Bay Warehouse 24V

Terminal no.	Function	Input/Output
1	power supply (+) actuators	24V DC
2	power supply (+) sensors	24V DC
3	power supply (-)	0V
4	power supply (-)	0V
5	reference switch horizontal axis	I1
6	light barrier inside	I2
7	light barrier outside	I3
8	reference switch vertical axis	I4
9	trail sensor (signal 1, bottom)	A1
10	trail sensor (signal 2, top)	A2
11	encoder horizontal axis impulse 1	B1
12	encoder horizontal axis impulse 2	B2
13	encoder vertical axis impulse 1	B3
14	encoder vertical axis impulse 2	B4
15	reference switch cantilever front	I5
16	reference switch cantilever back	I6
17	motor conveyor belt forward	Q1 (M1)
18	motor conveyor belt backward	Q2 (M1)
19	Motor horizontal to the shelf	Q3 (M2)
20	Motor horizontal to the conveyor belt	Q4 (M2)
21	motor vertical axis down	Q5 (M3)
22	motor vertical axis up	Q6 (M3)
23	motor cantilever forward	Q7 (M4)
24	motor cantilever backward	Q8 (M4)

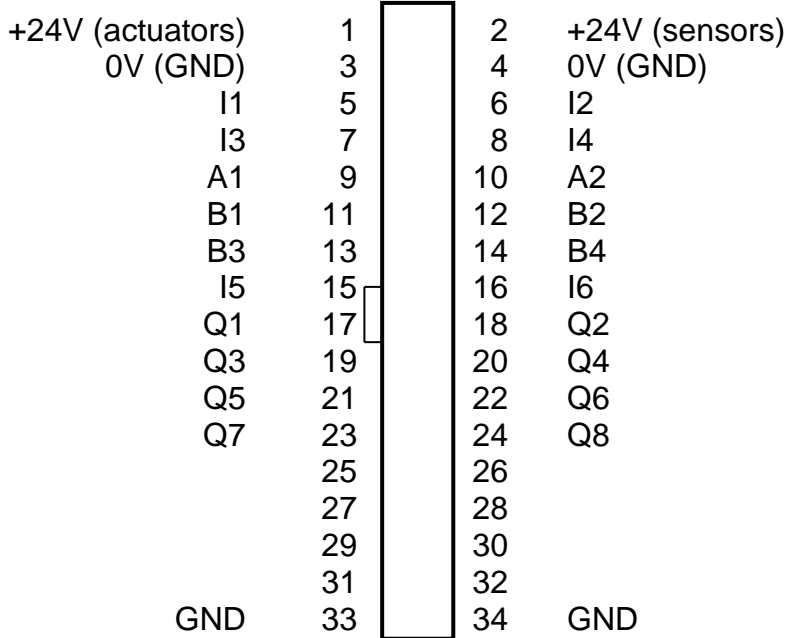

Circuit layout for Multi Processing Station with Oven 24V

Terminal no.	Function	Input/Output
1	power supply (+) actuators	24V DC
2	power supply (+) sensors	24V DC
3	power supply (-)	0V
4	power supply (-)	0V
5	reference switch turn-table (position vacuum)	I1
6	reference switch turn-table (position belt)	I2
7	light-barrier end of conveyor belt	I3
8	reference switch turn-table (position saw)	I4
9	reference switch vacuum (position turn-table)	I5
10	reference switch oven feeder inside	I6
11	reference switch oven feeder outside	I7
12	reference switch vacuum (position oven)	I8
13	light-barrier oven	I9
17	motor turn-table counterclockwise	Q1 (M1)
18	motor turn-table counterclockwise	Q2 (M1)
19	motor conveyor belt forward	Q3 (M2)
20	motor saw	Q4 (M3)
21	motor oven feeder retract	Q5 (M4)
22	motor oven feeder extend	Q6 (M4)
23	motor vacuum towards oven	Q7 (M5)
24	motor vacuum towards turn-table	Q8 (M5)
25	light oven	Q9
26	Compressor	Q10
27	Valve vacuum	Q11
28	valve lowering	Q12
29	valve oven door	Q13
30	valve feeder	Q14

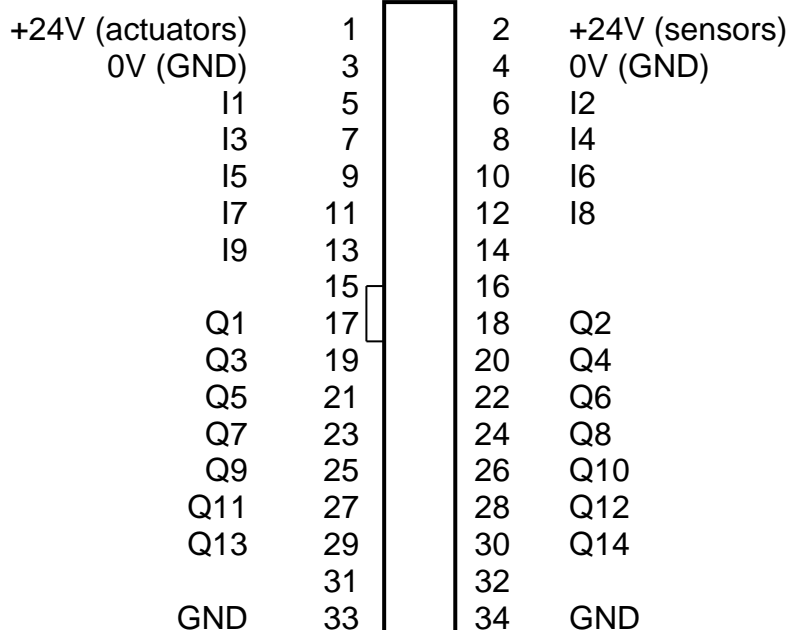

Circuit layout for Sorting Line with Detection 24V

Terminal no.	Function	Input/Output
1	power supply (+) actuators	24V DC
2	power supply (+) sensors	24V DC
3	power supply (-)	0V
4	power supply (-)	0V
5	pulse counter	I1
6	light-barrier inlet	I2
7	light-barrier behind color sensor	I3
8	Not used	
9	color sensor	I4
10	light-barrier white	I5
11	light-barrier red	I6
12	light-barrier blue	I7
17	motor conveyor belt	Q1
18	Compressor	Q2
19	Not used	
20	valve first ejector (white)	Q3
21	valve second ejector (red)	Q4
22	valve third ejector (blue)	Q5

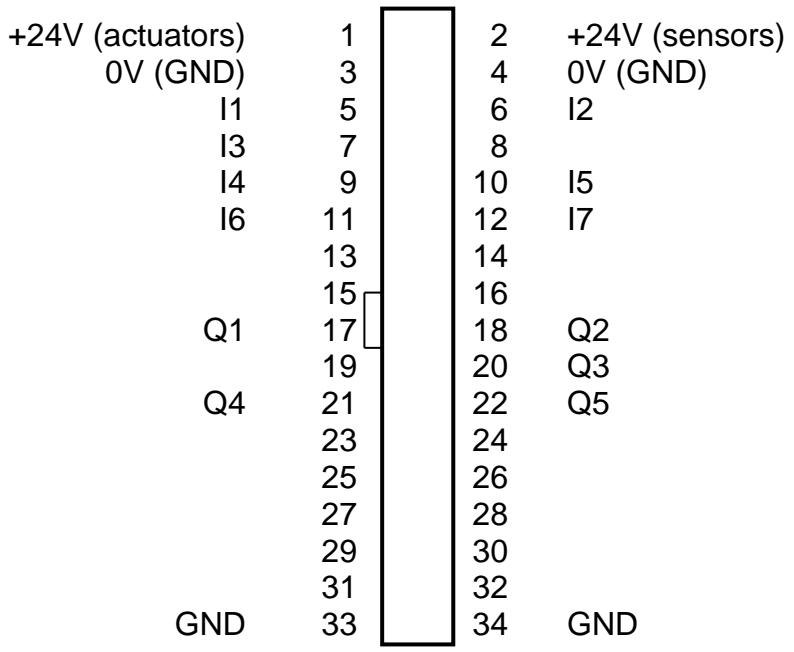

PLC input and output configuration

	Inputs	Outputs
Type	Sinking input	Sourcing output
Switching		

Component description

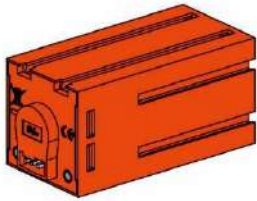

Encoder motor:

The vacuum gripper robot and the vertical and horizontal axes of the automated high-bay warehouse are driven with so-called encoder motors. This is possible through permanent magnet DC motors, which enable the incremental measurement of angles with the help of Hall effect sensors. The encoder motors have a rated voltage of 24 V and a maximum output of 2.03 W at 214 rpm. The current input at maximum power is 320 mA. The integrated gearbox gear ratio is 25:1. This means that the encoder produces three pulses per motor shaft rotation or 75 pulses per rotation of the gearbox output shaft. Since two phase shifted pulses are indexed, the encoder is able to distinguish the direction in which the motor is rotating.

The connection is made via a four core cable with a red wire for the 24 V output and a green wire for the ground connection. The black and yellow wires transmit the pulse (push-pull output, 1 kHz max., 10 mA max.).



Phototransistor:

Phototransistors are used as light barriers in the factory simulation. A phototransistor conducts electricity from a certain level of brightness. However, if this luminescence threshold is exceeded, the phototransistor loses its conductivity. Together with a lens tip lamp, which faces the phototransistor, the phototransistor can be used as a light barrier. If the cone of light from an object is interrupted, the light barrier no longer conducts electricity. A stray light hood can be used to reduce the effects of ambient light.

Caution: When connecting the phototransistor to the power supply, pay particular attention to correct polarity. Connect the positive pole at the red marking on the phototransistor.

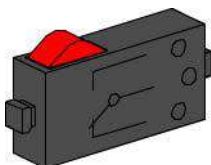

Mini-switch:

With the factory simulation the mini-switches are frequently used as reference switches. When using incremental measuring methods, a

reference switch is used to determine the absolute position or absolute angle. The mini-switch used for this purpose includes a changeover switch and can be used both as a normally closed contact and as a normally open contact. When the switch is actuated, equipotential bonding occurs between contact 1 and contact 3, while the connection between contact 1 and contact 2 is separated. Figure 3 shows the schematic circuit diagram of the mini-switch.

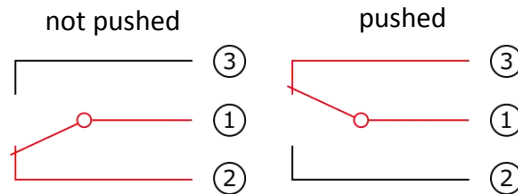
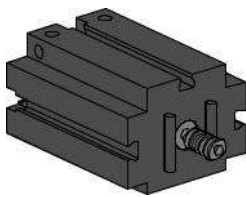
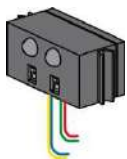

Figure 3: Mini-switch circuit diagram

S motor 24V:



Mechanical components, for example the conveyor belts, can be driven using the S-motor. This compact motor is a permanent magnet DC motor that can be used together with an attachable motor reducing gearbox. The motor is operated at a rated voltage of 24V DC and the maximum current input is 300 mA. The result is a maximum torque of 5 mNm and an idling speed of 10.700 rpm. The motor reducing gearbox has a gear ratio of 64.8:1 and a lateral output.



IR trail sensor:

The IR trail sensor is a digital infrared sensor, which can detect a black trail on a white background at a distance of 5 – 30 mm. It consists of two transmission and two receiver elements. The signals are output as push-pull outputs. The connection is made using four cables. The red cable must be connected to the 9V DC and the green cable must be connected to ground. The black and yellow cables transmit the signals. The adapter board converts the voltage and adjusts the level from 24V DC to 9V DC.

Compressor:

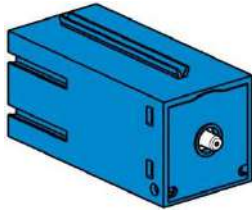

Diaphragm pumps are used as compressed air source for the pneumatic controls. This type of diaphragm pump consists of two chambers separated by a diaphragm (see Figure 4). A cam moves a piston in one of the two chambers up and down, causing the air in the other chamber to be drawn in or pressed out. If the piston moves to the right, the diaphragm is pulled back, causing air to be pulled into the second chamber through the inlet valve. If the piston moves to the left, the diaphragm presses the air out of the pumphead through the outlet valve. The compressor used in this case operates at a rated voltage of 24V DC and produces an overpressure of approximately 0.7 bar. The maximum current input of the compressor is 70 mA.

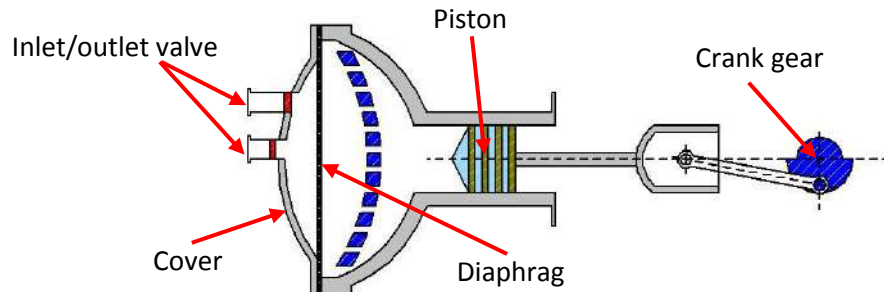
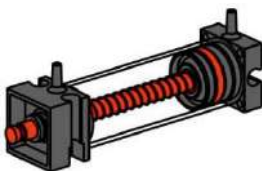

Figure 4: Schematic drawing of the diaphragm pump

Pneumatic cylinders:



Two pneumatic cylinders handle the suction function of the vacuum gripper robot and are controlled with the help of a 3/2 way solenoid valve. In the case of the pneumatic cylinders, a piston divides the volume of the cylinder into two chambers. Differing pressure between these two chambers results in force placed on the piston, causing the piston to move. This movement corresponds to a change in volume in both chambers. Two cylinders are then mechanically connected in order to create a vacuum, which is pressure that is lower than the ambient pressure. If a cylinder is then supplied with excess pressure, the two piston rods extend, causing the volume to increase in the chamber closed by the suction cup. This increase in volume is accompanied by a drop in pressure in this chamber.

color sensor

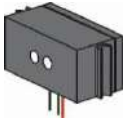

color sensors are mostly used in automation technology, for instance. During this process, for example, the color or a color imprint is to be examined to ensure that the correct components are installed. The fischertechnik color sensor transmits red light, which is reflected with a different intensity from different colored surfaces. The intensity of the reflected light is measured by the phototransistor and output as a voltage value between 0 V and 9 V. The measured value is dependent on the ambient brightness and the distance of the sensor from the colored surface. The connection is made using three cables. The red cable is connected to the 9V DC, the green cable is connected to ground and the black cable is connected to a universal input. The adapter board converts the voltage from 24V DC to 9V DC.

3/2 way solenoid valve:

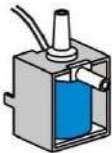

3/2 way solenoid valves are used to control the pneumatic cylinders. These control valves have three connection points and two control states. The switching operations are carried out by a solenoid coil (a), which operates against a spring (c). When voltage is applied to the solenoid, the movable core (b) of the coil moves against the spring as a result of Lorentz force, causing the valve to open. Open in this case means that the compressed air connection (current description: 1, previous description: P) is connected with the cylinder connection (2, previously A). If this voltage drops, the spring pushes the core back again, and the valve closes again. In this position, the cylinder connection (2, previously A) is connected with the air vent (3, previously R). Figure 5 shows a schematic drawing of the 3/2 way solenoid valve. The solenoid valve connection is made using two cables: one connected to the PLC output and the other connected to ground.

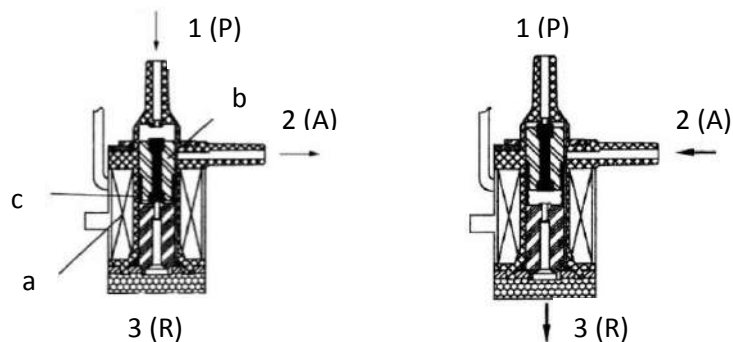

Figure 5: 3/2 way solenoid valve

Models

Vacuum gripper robot (VSG)

What are robots?

The Society of German Engineers (VDI) defines industrial robots in VDI guideline 2860 as follows:

“Industrial robots are universal handling systems with several axes whose motions with respect to movement sequence and paths or angles are freely programmable (i.e. with no mechanical or human intervention) or sensor-guided. They can be equipped with grippers, tools or other means of production and can perform handling and/or production tasks.”

The 3D vacuum gripper robot is therefore an industrial robot that can be used for handling tasks. A workpiece can be picked up with the help of the vacuum gripper robot and moved within a workspace. This workspace is the result of the kinematic arrangement of the robot, and it defines the area that can be reached by the robot's effector. In the case of the vacuum gripper robot, the suction cup of the effector and the workspace correspond to a hollow cylinder whose vertical axis coincides with the robot's axis of rotation.

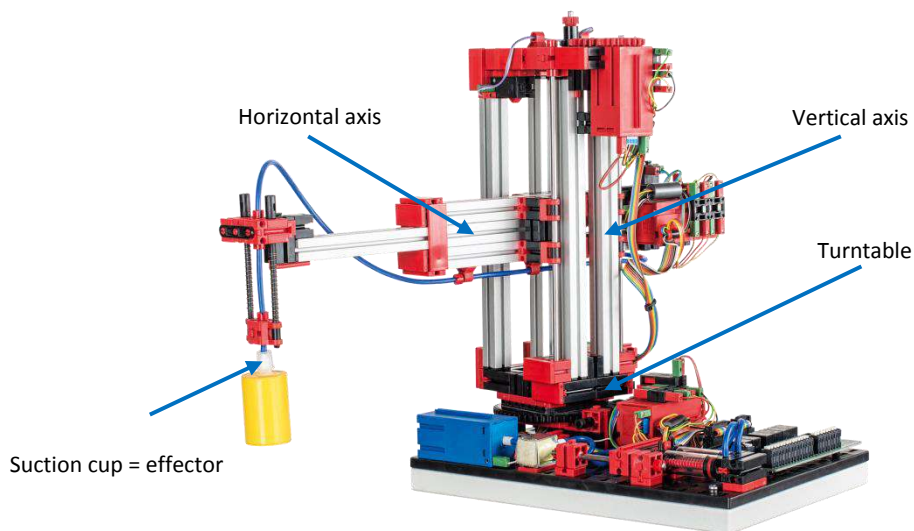

Figure 6: kinematic arrangement of the 3D vacuum gripper robot

The geometry of the workspace is the result of the kinematic setup shown in Figure 4 and comprises one rotary axis and two linear axes.

The typical job for this type of robot can be broken down into the following work steps:

- Positioning the vacuum gripper at the workpiece location
- Picking up the workpiece

- Transporting the workpiece within the workspace
- Setting down the workpiece

Positioning the vacuum gripper or transporting the workpiece can be defined as a point-to-point motion or as a continuous path. The individual axes can be controlled sequentially and/or parallel. This is significantly influenced by the obstacles or predefined intermediate stations present in the workspace.

It is practical to first integrate a reference run in the program in order to establish the absolute position or the absolute angle. To do this, the three axes of the robot are moved to their reference positions and then their positions or angles are set to zero. Now the position of the workpiece can be approached and the workpiece picked up.

The following steps can now be carried out sequentially:

- The gripper robot moves to the alternate position.
- Set the workpiece down.
- The gripper robot pauses at this position.
- Pick up the workpiece again.

For the position control the pulse count of the encoder and the direction of rotation of the motor is combined and can thus, since this is a monotonous movement, approach positions or angles precisely. During this the three axes can be controlled parallel, as long as there is no obstacle present in the workspace.

For this purpose the following measurement and set point values are required:

- Target position or target angle
- Actual position or actual angle
- State of reference switch
- Motor direction of rotation
- Measured encoder pulse

During the suction process of a workpiece the suction cup must first be lowered, in order to create an airtight connection between the workpiece and the suction cup. Then a vacuum must be created in order to temporarily fasten the workpiece on the suction cup. Now the suction cup can be lifted with the workpiece. The function for setting down the workpiece can also be divided into three sections. First the suction cup is lowered, then the air is removed from the cylinder, eliminating the vacuum, and finally the suction cup is raised again.

In the factory simulation the vacuum gripper robot (VSG) is the interface to the other models. Here the vacuum gripper robot should pick up the workpieces from the storage locations of the sorting line with detection and transport them to the "Conveyor system with identification" of the automated high-bay warehouse (HRL). The VSG should first pick up the workpieces from the first storage location (white), until the light barrier located there indicates that there is no more workpiece in the storage location. After this the other workpieces should be picked up in the same manner. It should now place the workpieces in the ready standing workpiece carrier on the conveyor system with identification. If all 9 workpieces (3 white, 3 red, 3 blue) are stored in the high-bay warehouse, these should be taken out of storage sequentially and brought to the multi processing station. For this the VSG should remove the workpieces from the standing ready workpiece carries, transported to the "oven" of the multi processing station and there placed on the extended oven slider. After the workpieces in the sorting line have been sorted according to color, the vacuum gripper robot should transport these back to the high-bay warehouse.

Industrial robots – definition and characteristics

Name five key words that describe an industrial robot according to VDI guideline 2860.

What tasks can the vacuum gripper robot be used for?

What is considered a robot workspace and how is this space defined?

What is the shape of the vacuum gripper robot workspace?

What is the kinematic arrangement of the vacuum gripper robot?

Industrial robots – definition and characteristics

ANSWER

Name five key words that describe an industrial robot according to VDI guideline 2860.

- *Universal handling systems with several axes*
- *Freely programmable with respect to movement sequence and paths or angles*
- *Possibly sensor-guided*
- *Can be equipped with grippers, tools or other means of production*
- *Can perform handling and/or production tasks*

What tasks can the vacuum gripper robot be used for?

The vacuum gripper robot can be used for handling tasks.

What is considered a robot workspace and how is this space defined?

The workspace of an industrial robot is the area that can be reached by the robot's effector. The workspace is defined by the kinematic arrangement of the robot, which is determined by the type and arrangement of the movable axes.

What is the shape of the vacuum gripper robot workspace?

The workspace of the vacuum gripper robot can be described as a hollow cylinder.

What is the kinematic arrangement of the vacuum gripper robot?

The kinematic arrangement of the vacuum gripper robot consists of a turntable and two linear axes.

Kinematic arrangement of the vacuum gripper robot

Identify and name the movable axes and effector of the vacuum gripper robot.

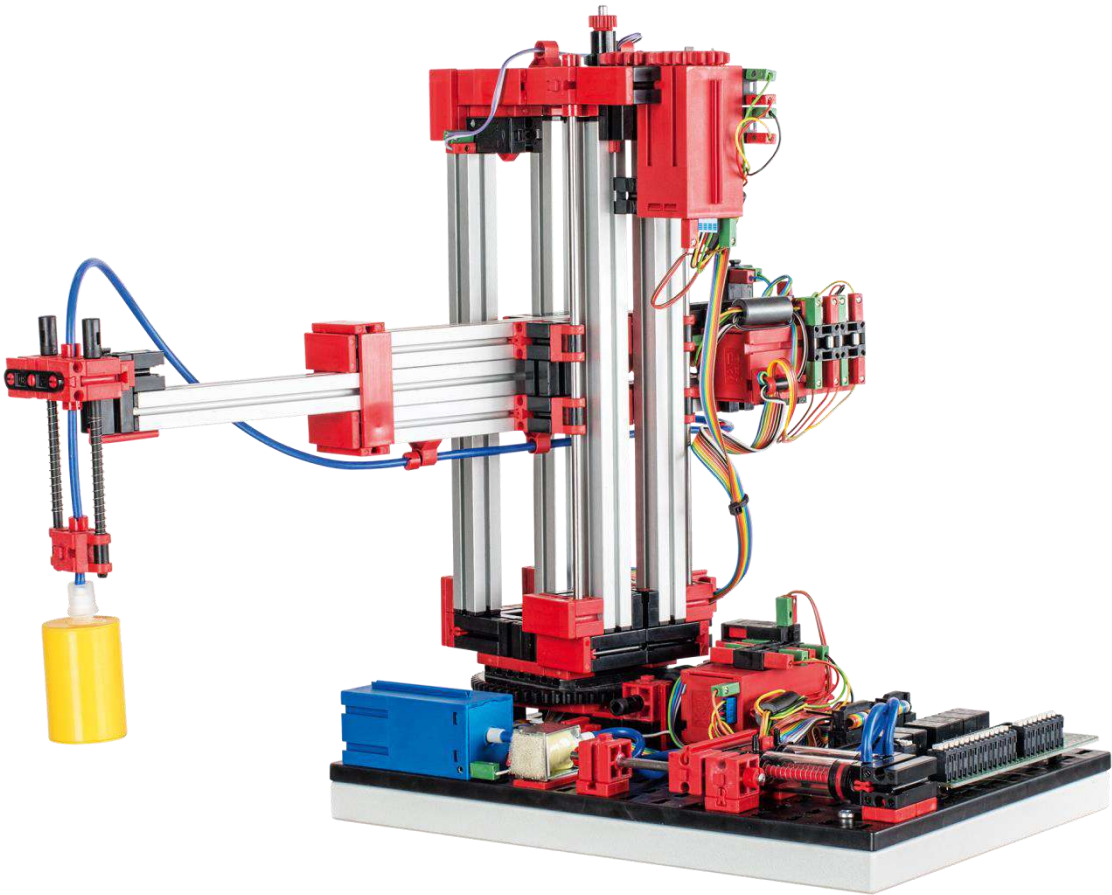

Kinematic arrangement of the vacuum gripper robot

ANSWER

Identify and name the movable axes and effector of the vacuum gripper robot.

1 Turntable

2 Horizontal axis

3 Vertical axis

4 Suction cup

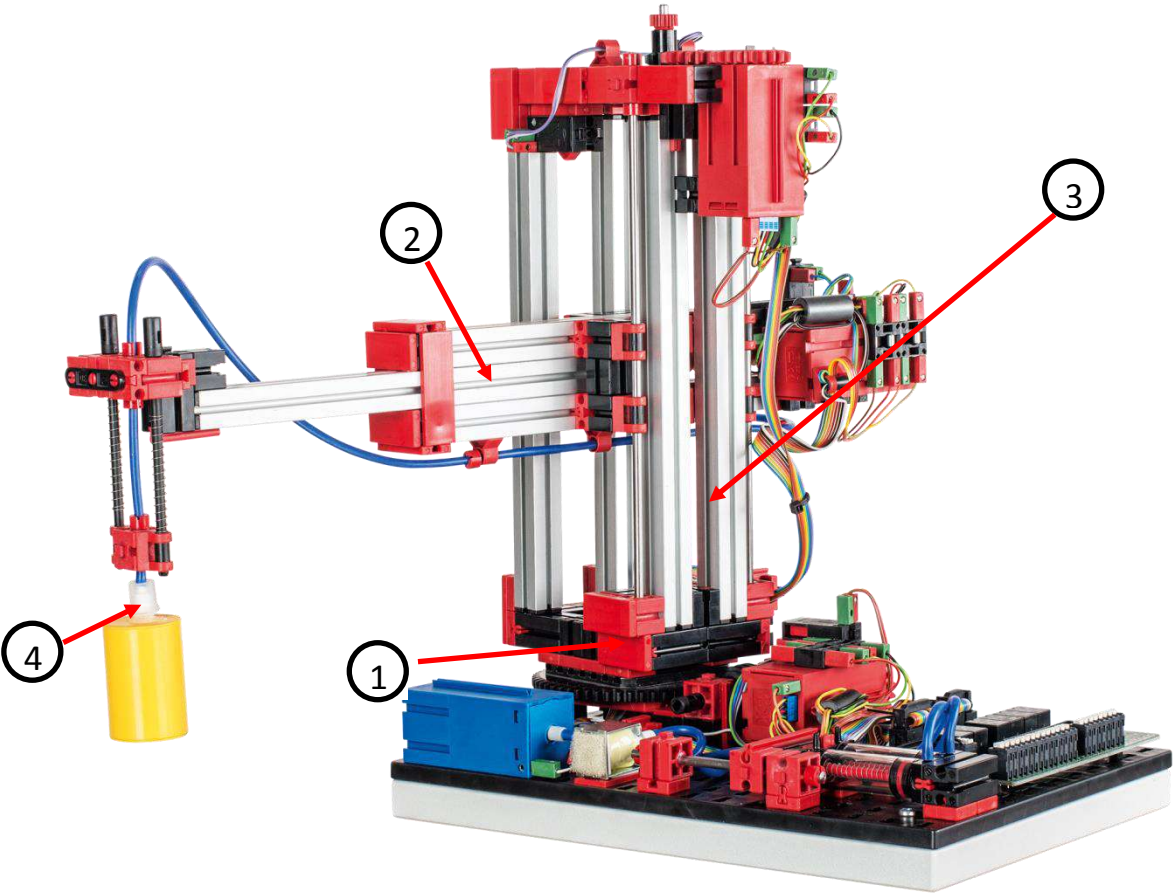

Handling tasks

Name the four typical jobs of the vacuum gripper robot.

For which two job types can positioning jobs be defined?

What controls the individual axes of the robot? What significantly influences actuation?

Why are reference runs necessary? Which measuring method requires reference runs?

Handling tasks

ANSWER

Name the four typical jobs of the vacuum gripper robot.

- *Positioning the vacuum gripper at the workpiece location*
- *Picking up the workpiece*
- *Transporting the workpiece within the workspace*
- *Setting down the workpiece*

For which two job types can positioning jobs be defined?

- *Point-to-point motions*
- *Continuous path*

What controls the individual axes of the robot? What significantly influences actuation?

The axes of the vacuum gripper robot can be actuated sequentially and/or in parallel.

Actuation is significantly affected by obstacles in the workspace and by predefined intermediate stations.

Why are reference runs necessary? Which measuring method requires reference runs?

Reference runs help to define the absolute position or absolute angle.

They are used for incremental measuring.

Maintenance and troubleshooting

The vacuum gripper robot is generally maintenance free. It may be necessary to re-grease the worm or worm screw nut. Keep in mind that it is possible to avoid a friction-type connection by applying a thin layer of grease at specific locations.

Problem: One of the three motors/axes is no longer moving.

Solution: Visually inspect the robot. Specifically check the cabling of the failed motor. If necessary, use a multimeter to check if there is a broken cable.

Problem: One of the three motors/axes no longer moves to the positions correctly and pauses briefly in front of the desired position.

Solution: Verify that the robot chucks and chuck nuts are secured tightly. If not, it is possible that there could be slippage between the friction lock parts.

Problem: The suction cup loses the workpiece during transport.

Solution: Visually inspect the hose system. Make sure that the two connected pneumatic cylinders can extend freely and, if necessary, moisten the suction cup. Make sure that the workpieces are not dirty in order to ensure an air-tight connection between the suction cup and workpiece.

Automated high-bay warehouse (HRL)

What is a high-bay warehouse?

A high-bay warehouse is a space-saving storage area for storing and retrieving goods. In most cases high-bay warehouses are designed as pallet rack storage systems. This standardization provides for a high level of automation and connection to an ERP (Enterprise Resource Planning) system. High-bay warehouses are characterized by superior space utilization and high initial capital costs.

Storing and retrieving goods is handled by rack feeders that move in a lane between two rows of racks. This area is part of the receiving station, where identification of goods also takes place. Using conveyor systems, such as chain, roller or vertical conveyors, the goods arrive and are transferred to the rack feeders. If the rack feeders are automated, no one is allowed to enter this area. In the case of the automated high-bay warehouse, the goods are provided on a conveyor belt. The goods are identified by a barcode, which is ready by the trail sensor.

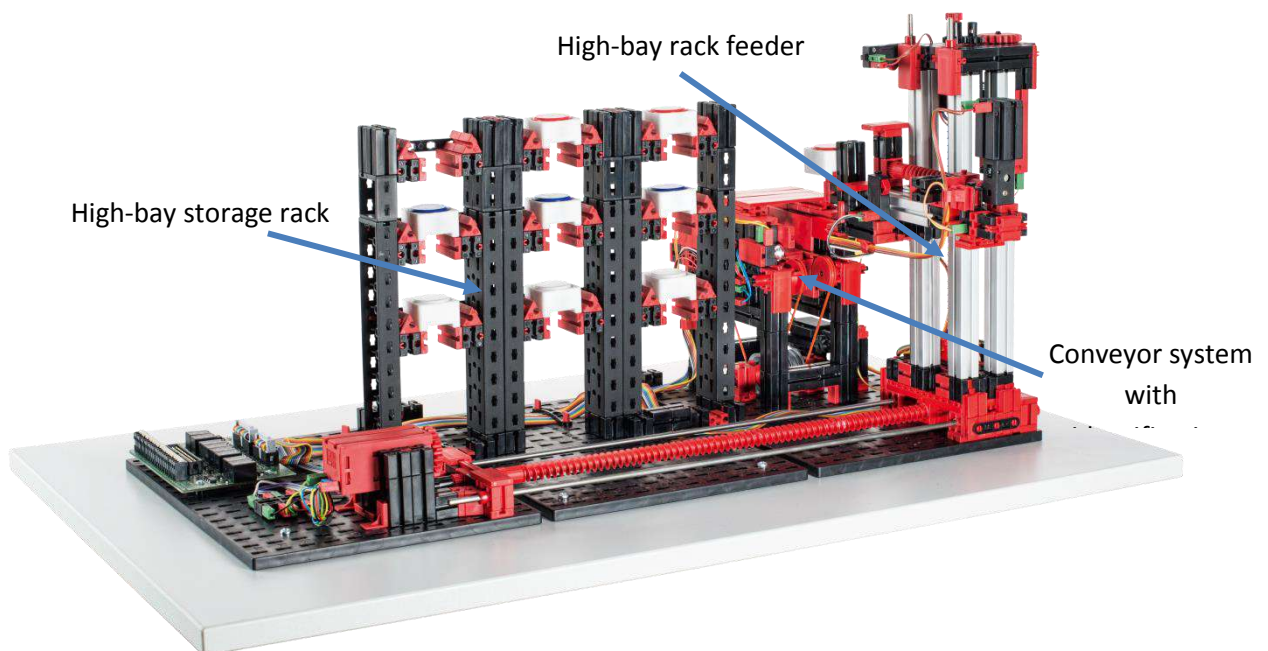

Figure 7: High-bay warehouse areas

Goods are frequently stored based on the dynamic warehousing principle. There is no fixed arrangement between storage position and goods, so the goods to be stored are placed in any free spot. This promises path efficiency. The warehouse management system saves the position of the stored goods, making them available. A (partly) automated identification of goods, which is usually done using FRID chips or barcodes at a central location called the identification site, and standardization of storage areas (same external dimensions, same permitted unit weights) are indispensable.

The ABC strategy in which the warehouse is divided into three zones at varying distances from the storage/retrieval area, is used to further streamline the pathways. Frequently required goods are

placed in the A zone, which is directly next to the storage/retrieval area. Rarely needed goods are correspondingly stored in the C zone, which is far away from the storage/retrieval area.

With the automated high-bay warehouse you can demonstrate both the dynamic and the static storage. In the case of static warehousing, for instance, each row is assigned a color. For instance, the top row is assigned the color white, the middle row is assigned red and the bottom row is assigned blue. The individual colored rows are filled from the position closest to the pre-loading zone to the position farthest away from the pre-loading zone.

Regardless of whether you want to use the static or dynamic warehousing, it is practical to first integrate a reference run of the high-bay rack feeder. To do this move the vertical and horizontal axes to their reference positions and then set their positions to zero.

For the factory simulation the static warehouses is suitable, since the workpiece carrier is already in the high-bay warehouse and the workpieces are sorted from the sorting line. If the rack management is now designed so that the high-bay warehouse is filled in sequence, the workpieces are automatically stored sorted by color, since the VSG picks up the sorted workpieces from the storage locations of the sorting line. Thus the white workpieces are stored in the top row, the red workpieces in the center row and the blue workpieces in bottom row. For this no signals of the track sensor are required and simplifies the program.

While the vacuum gripper robot transports a workpiece from the storage locations to the HRL, the rack feeder simultaneously picks up an empty workpiece carrier from the high-bay warehouse and places on the conveyor belt of the "conveyor system with identification". The conveyor belt should now transport the workpiece carriers to the other end of the conveyor belt. When the VSG has placed the workpiece in the workpiece carrier, the workpiece carrier including the workpiece should be conveyed by the track sensor and place on the extension of the rack feeder. Then the rack feeder should store the workpiece on the corresponding storage location. To remove from storage the rack feeder should remove the loaded workpiece carriers and transport to the conveyor system with identification. From there the vacuum gripper robot can remove the workpiece again.

However, if a dynamic warehousing is desired, the signal of the track sensor must be implemented. In addition the barcodes shown in Figure 8 must be placed on the workpiece carriers, so that it can be differentiated between the three colors (white, red and blue).

The workpiece is identified by the automated high-bay warehouse using a simple barcode. The workpiece carriers have a code on them, which is assigned the color white, red or blue. This code is analyzed by a trail sensor. Here the track sensor registered light/dark differences and now these must be assigned a color.

The time interval is limited through the two light barriers before and after the identification unit. Since undesirable reflections can occur on the edges of the workpiece carriers, these must be dismissed in order to avoid false interpretations. This can be dealt with if the width of the light areas (reflective points) or the number of sequential time increments are interpreted as light. So then, for example, the light areas which include more than five sequential time steps can be evaluated as marking and those which have less than five sequential time steps as reflection. This thus defined minimum width limits the number of patterns to be distinguished which can be used to identify the workpiece, but it is sufficient for coding the three colors.

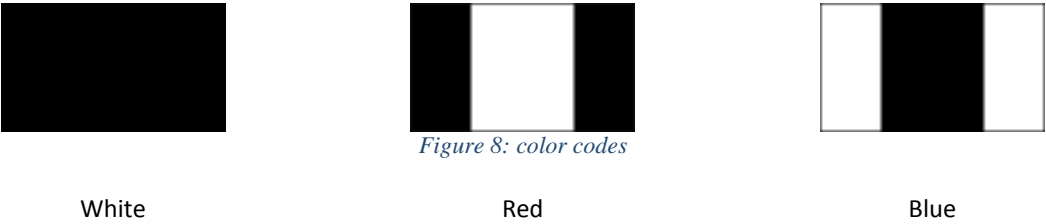

Figure 8 shows the assignment between the codes used and the respective colors. These marks are applied to the workpiece carrier side facing the trail sensor, thus allowing assignment of a workpiece carrier to a colored workpiece.

High-bay warehouse – definition and characteristics

What is a high-bay warehouse?

What is the pre-loading zone?

Identify and label the important areas of the automated high-bay warehouse.

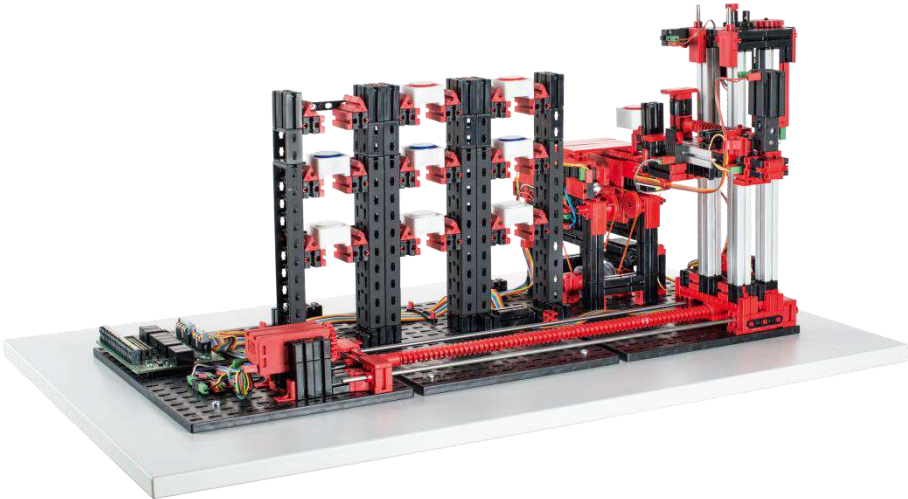

High-bay warehouse – definition and characteristics

ANSWER

What is a high-bay warehouse?

A high-bay warehouse is a space-saving storage area for computer-assisted storage and retrieval of goods and as a result of high standardization provides for a high level of automation.

What is the pre-loading zone?

The pre-loading zone is the high-bay warehouse area where the goods are prepared and identified. The pre-loading zone also includes the high-bay rack feeder and conveyor system.

Identify and label the important areas of the automated high-bay warehouse.

1 High-bay storage rack

2 Conveyor system with identification

3 High-bay rack feeder

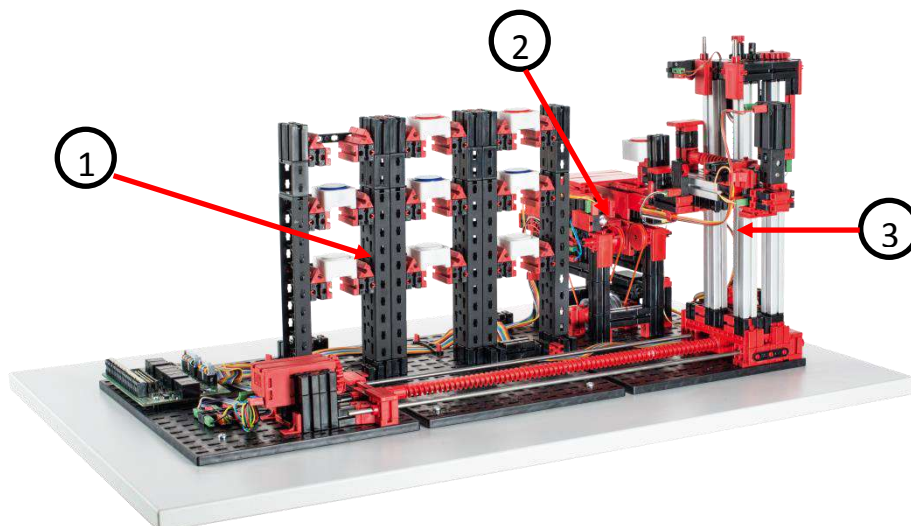

Dynamic warehousing

What are the two requirements for using dynamic warehousing?

What does dynamic warehousing promise?

How can dynamic warehousing be streamlined further?

Use the ABC strategy on the automated high-bay warehouse.

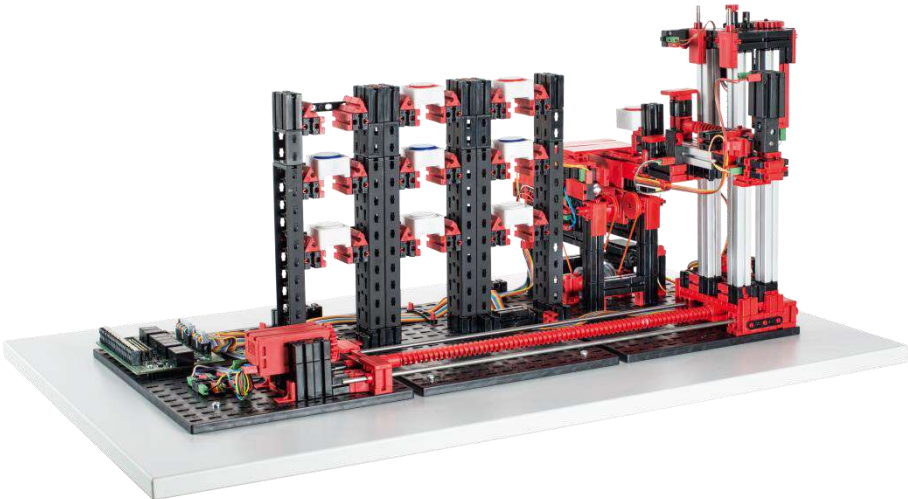

Dynamic warehousing

ANSWER

What are the two requirements for using dynamic warehousing?

- *(Partially) automated identification of goods*
- *Standardization of storage areas*

What does dynamic warehousing promise?

- *Streamlined pathways*
- *Efficient utilization of storage space*

How can dynamic warehousing be streamlined further?

By using the ABC strategy in which frequently required goods are placed close to the storage and retrieval area and rarely needed goods are placed far away from the storage and retrieval area.

Use the ABC strategy on the automated high-bay warehouse.

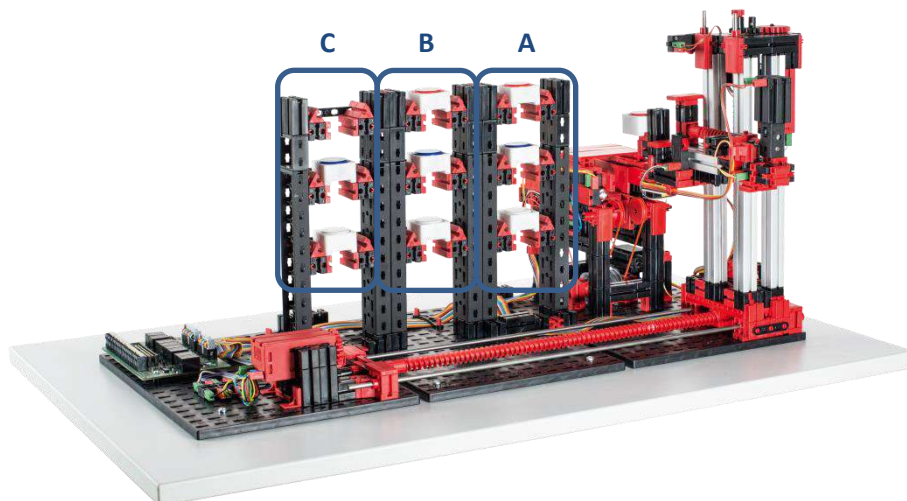

Maintenance and troubleshooting

The automated high-bay warehouse is generally maintenance free. If necessary the grease on the worms and worm screw nuts can be replaced. Keep in mind that it is possible to avoid a friction-type connection by applying a thin layer of grease at specific locations.

Problem: One of the three motors/axes is no longer moving.

Solution: Visually inspect the high-bay rack feeder. Specifically check the cabling of the failed motor. If necessary, use a multimeter to check if there is a broken cable.

Problem: One of the three motors/axes no longer moves to the positions correctly and pauses briefly in front of the desired position.

Solution: Verify that the robot chucks and chuck nuts are secured tightly. If not, it is possible that there could be slippage between the friction lock parts.

Problem: The conveyor belt does not move or does not move far enough even though there is a workpiece on it.

Solution: One of the two conveyor belt light barriers is not working. Check the light barrier cables and make sure that they are not covered by shifting components.

Multi processing station with oven

In the case of the multi processing station with oven, the workpiece automatically runs through several stations that simulate different processes. These processes use different conveyor systems, such as a conveyor belt, a turntable and a vacuum gripper robot. Processing begins with the oven. The processing starts as soon as the vacuum gripper robot places the workpiece on the oven feeder. The light barrier is interrupted when this happens, thus opening the oven door and drawing in the oven feeder. At the same time, the vacuum gripper is called, which brings the workpiece to the turntable after the firing process. Following the firing process, the door of the oven should be opened again and the oven feeder move outward again. The already positioned gripper robot should pick up the workpiece as with the VSG, transport it to the turntable and set it down there. Provisions are made that the turntable positions the workpiece under the saw, waits there for the duration of processing and then moves to the position on the conveyor belt. There the pneumatic actuated ejector should push the workpiece onto the conveyor belt, which conveys the workpiece to a light barrier and then transfers it to the sorting line with detection. Crossing the light barrier should cause the turntable to return to its starting position and the conveyor belt to come to a delayed stop.

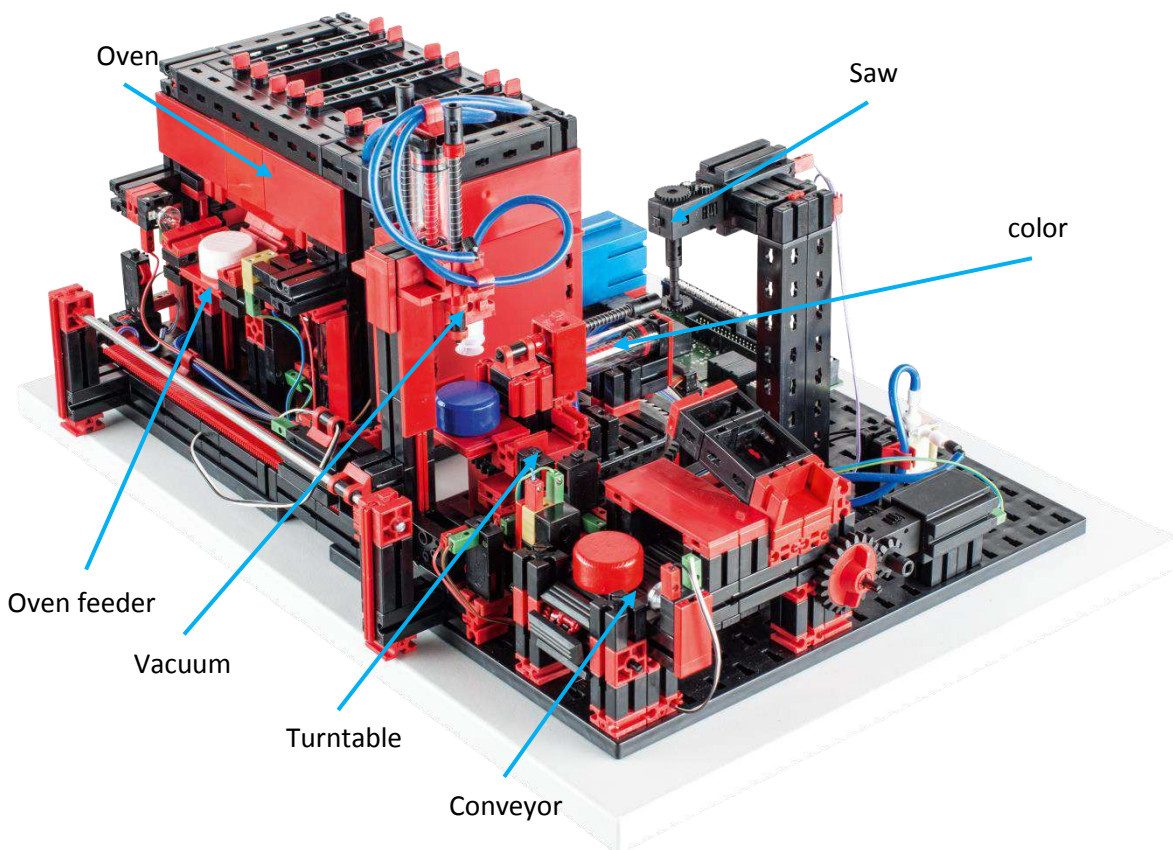

Figure 9: Areas of the multi processing station with oven

The program sequence can be controlled due to the many inputs and outputs present. Therefore it is practical here to divide the program into three units: oven, vacuum gripper robot and turntable. The

particular processes should communicate with each other and thereby ensure that no collisions occur.

Multi processing station with oven

Identify the “oven”, “vacuum gripper robot”, “turntable” and “conveyor belt” components.

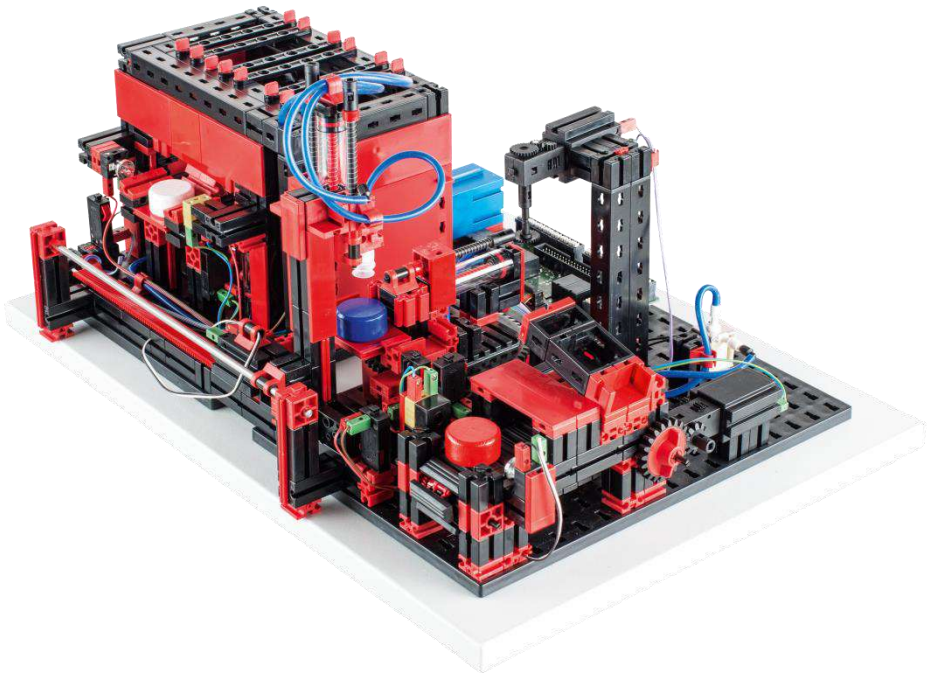

Which three conveyor systems are used with the multi processing station with oven?

Multi processing station with oven

ANSWER

Identify the “oven”, “vacuum gripper robot”, “turntable” and “conveyor belt” components.

1. *Oven*
2. *Vacuum gripper robot*
3. *Turntable*
4. *Conveyor belt*

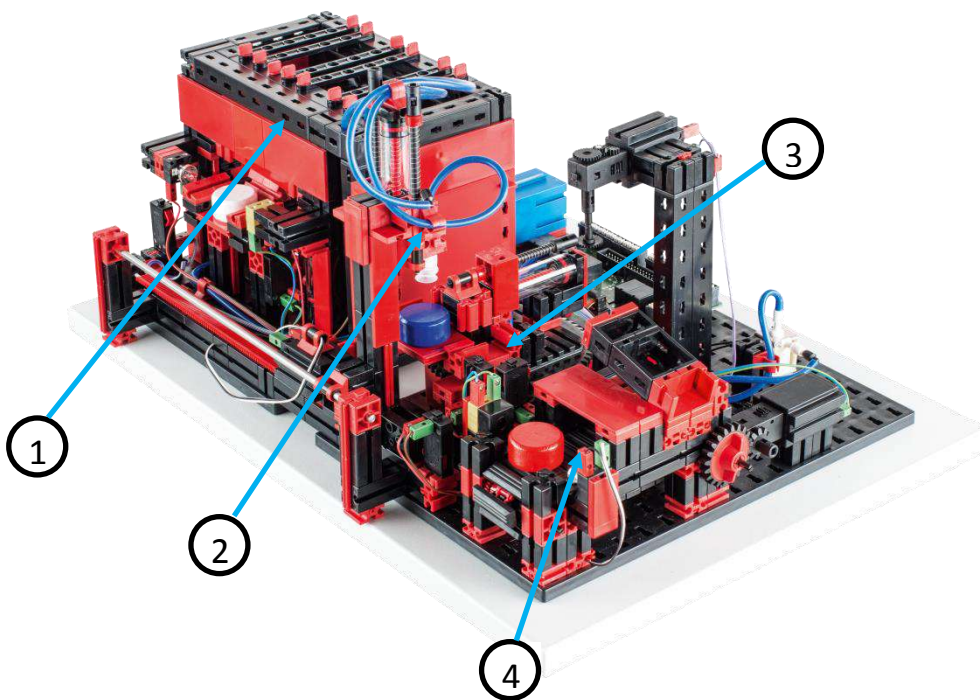

Which three conveyor systems are used with the multi processing station with oven?

- Conveyor belt*
- Turntable*
- Vacuum gripper robot*

Maintenance and troubleshooting

The multi processing station with oven is generally maintenance free.

Problem: **The vacuum gripper robot loses workpieces during transport.**

Solution: Make sure that the hose connection (Art. No. 35328) end is flush with the top edge of the suction cup. Make sure that the surface of the workpiece is free of contaminants. It may help to moisten the vacuum gripper robot.

Problem: **The light barrier on the oven does not detect that a workpiece is on the feeder.**

Solution: The light barrier detects that the workpiece has been set down, but does not detect the presence of the workpiece. To start the processing, you can manually interrupt the light barrier. Also make sure that phototransistor will not be triggered by the ambient light.

Problem: **The door of the oven does not open/close, or the workpiece is no longer pushed off the turntable.**

Solution: Verify that all pneumatic hoses are connected correctly and that the compressor is working properly.

Sorting line with detection

The sorting line with detection is used for the automated separation of different colored building blocks. In this process, a conveyor belt conveys geometrically identical, yet different colored components to a color sensor, where they are separated according to their color. The conveyor belt is powered by an S motor and the transport route is measured with the help of a pulse switch. The ejection of workpieces is handled by pneumatic cylinders, which are assigned to the appropriate storage locations and are actuated by solenoid valves. Several light barriers control the flow of the workpieces and whether the workpieces are in the storage locations.

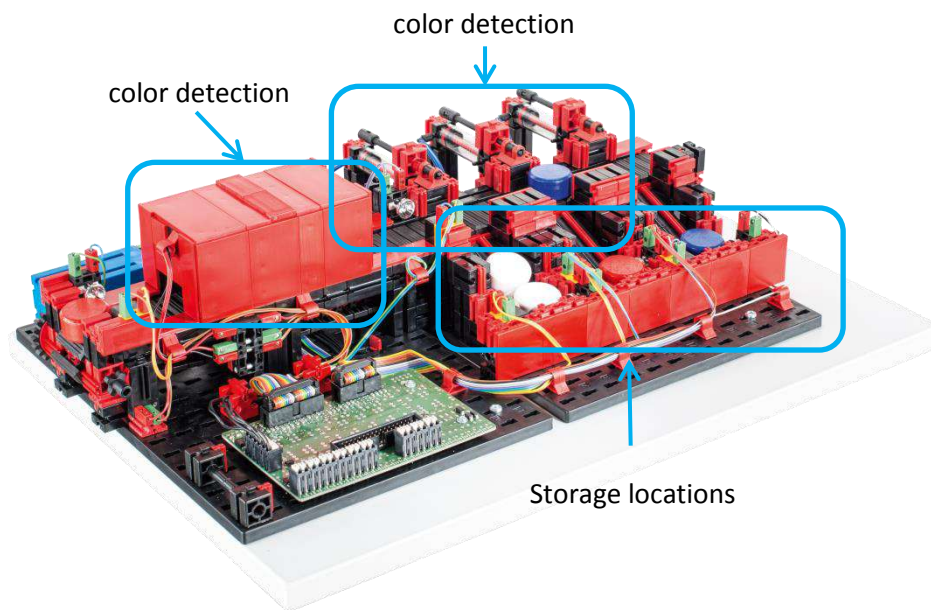

Figure 10: Areas of the sorting line with detection

During this process, color detection is handled by an optical color sensor, which emits a red light and can detect their color based on a surface reflection. Technically speaking the color sensor is therefore a reflective sensor which indicates how well a surface reflects light. The sensor's measured value is therefore not proportional to the wavelength of the measured color and even the assignment of color coordinates or color spaces (e.g. RGB or CMYK) is not possible. In addition to the object's color, ambient light, the surface of the object and the distance of the object from the sensor influence the quality of the reflection. For this reason, it is imperative that the color sensor is protected from ambient light and the surface of the objects are similar. In addition, it is important that the sensor is installed perpendicularly to the object's surface. Threshold values that limit the measured values of individual colors make a distinction between the colored workpieces. Since the value ranges of different color sensors differ, these limit values must absolutely be determined.

The process should be started and the conveyor belt switched on as soon as a workpiece is transferred from the processing station to the conveyor belt of the sorting line and in the process interrupts the light barrier. For the color detection the workpiece runs through a darkened sluice, in

which a color sensor is installed. During this time interval the color should be measured and the workpiece assigned. During this the measured value should be compared with two limit values to assign the workpiece the colors white, red or blue. While the first limit value (for example "limit1") can be used to distinguish between white and red, the second limit value (for example "limit2") can be used to distinguish between red and blue. These limit values must be determined with the aid of tests. Ejection can be controlled with the help of the light barrier located before the first ejector. Depending on the color value detected, the corresponding pneumatic cylinder can be triggered with a delay after the light barrier is halted by the workpiece. This is where the pulse switch comes in, which senses the rotation of the gear wheel driving the conveyor belt. Unlike a time-dependent delay, this approach can withstand disruptions in the conveyor belt speed. The ejected workpieces are fed through three chutes to the particular storage locations. During this the storage location, which is found closest to the detection is assigned the color white, the center the color red and the furthest away the color blue. The storage locations are equipped with light barriers that detect whether the storage location is filled or not. However, the light barriers cannot tell how many workpieces are in the storage location.

From this storage location the vacuum gripper robot can now again pick up the workpiece and transport it to the high-bay warehouse to store it there again.

color detection

Briefly describe how the color sensor, which is used in the sorting line, works.

Which interference factors can affect the measured value of the color sensor?

What are the physical requirements to ensure fault-free operation of the color sensor?

Name two common color spaces.

What might a color sensor look like that consists of reflective sensors and outputs an actual color value?

color detection

ANSWER

Briefly describe how the color sensor, which is used in the sorting line, works.

The color sensor used is a reflective sensor. It measures the reflection of red light, which is reflected by the object to be measured.

Which interference factors can affect the measured value of the color sensor?

Ambient light

Surface of the detected object

Reflection angle

What are the physical requirements to ensure fault-free operation of the color sensor?

The color sensor must be protected from ambient light (e.g. housing)

The surface of the objects to be measured must be similar.

Name two common color spaces and name their basic colors.

RGB (red - green - blue)

CMYK (cyan - magenta - yellow - key (black))

What might a color sensor look like that consists of reflective sensors and outputs an actual color value?

A color sensor that outputs an actual color value must consist of three reflective sensors. In the RGB color space, these sensors must emit red, green and blue light sequentially and then measure each reflection.

Sorting line with detection

Identify the “color detection”, “ejector” and “storage location” areas.

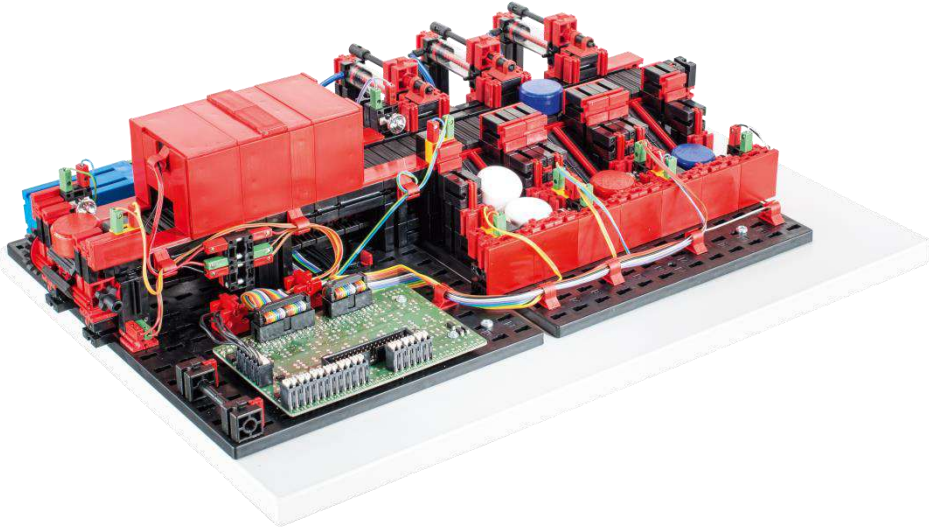

Sorting line with detection

ANSWER

Identify the “color detection”, “ejector” and “storage location” areas.

1. *color detection*
2. *color detection*
3. *Storage locations*

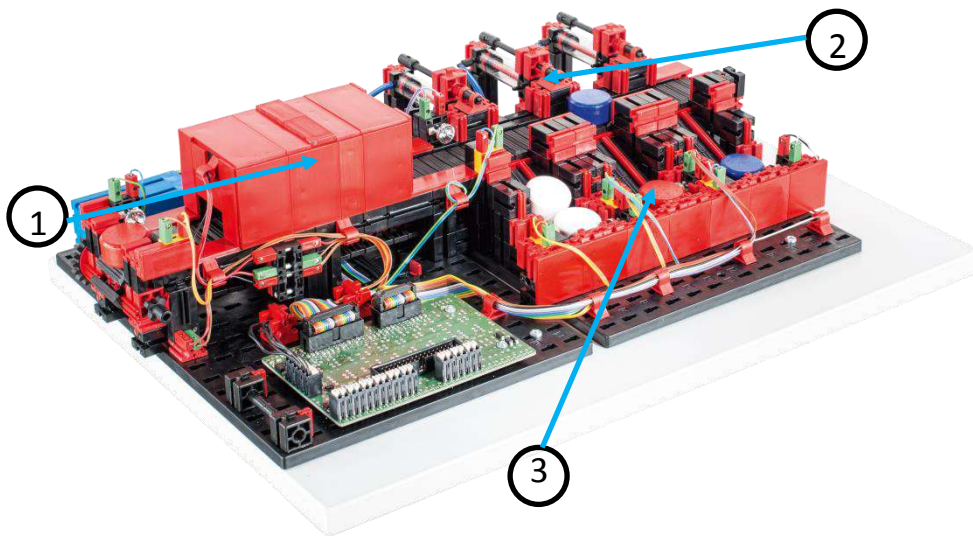

Maintenance and troubleshooting

The sorting line is generally maintenance free.

Problem: **The sorting line is not sorting the colored workpieces correctly.**

Solution: Adapt the limit values. Also make sure that ambient light is not interfering with the color sensor.

Problem: **The workpieces are not being pushed off, but the conveyor is still in the correct location.**

Solution: Make sure that the pneumatic hoses are connected correctly and that the compressor is running correctly.

Problem: **The conveyor belt is not starting or is stopping too soon.**

Solution: Verify that the light barriers in front of the color detector and in front of the ejector are working correctly and that they are connected properly. When doing so, make sure the polarity of the phototransistor is correct.