

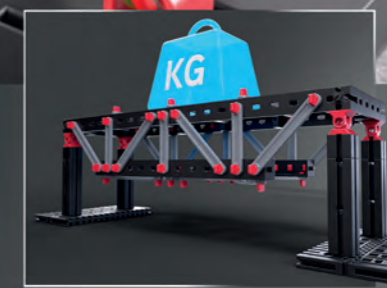

160982 - 02/23 - Co - Printed in Germany - Technische Änderungen vorbehalten - Subject to technical modifications



# PROFI Mechanic & Static 2

**fischertechnik GmbH**  
Klaus-Fischer-Str. 1  
72178 Waldachtal  
Germany

Phone: +4974 43/12-43 69  
Fax: +4974 43/12-45 91

info@fischertechnik.de  
www.fischertechnik.de

[www.fischertechnik.de](http://www.fischertechnik.de)

Bauanleitung  
Assembly instruction  
Instructions de montage  
Bouwhandleiding  
Instrucciones de construcción

Manual de montagem  
Istruzioni di montaggio  
Инструкция по сборке  
安装说明书

# PROFI Mechanic & Static 2

MODELS

**30**





- Mit dem fischertechnik eLearning Portal geben wir dir die Möglichkeit, noch mehr Hintergrundwissen zum Thema des Baukastens zu erhalten. Über <https://www.fischertechnik.de/elearning-mechanicstatic2> gelangst du direkt zum Portal.
- The fischertechnik eLearning Portal provides even more background knowledge on the topic of the building set. You can access the portal directly at <https://www.fischertechnik.de/elearning-mechanicstatic2>.
- Avec le portail e-learning fischertechnik, nous t'offrons la possibilité d'acquérir encore plus de connaissances de base au sujet du kit de construction. Tu peux accéder directement au portail via le lien <https://www.fischertechnik.de/elearning-mechanicstatic2>.

- Met het fischertechnik eLearning portaal geven wij jou de mogelijkheid, om meer achtergrondkennis over het thema van de bouwdoos te verkrijgen. Via <https://www.fischertechnik.de/elearning-mechanicstatic2> kom je rechtstreeks op het portaal.
- Con el portal de eLearning de fischertechnik, te damos la posibilidad de obtener aún más conocimientos básicos sobre el tema del kit de montaje. Para acceder al portal, accede en <https://www.fischertechnik.de/elearning-mechanicstatic2>.
- Com o portal de aprendizagem virtual da fischertechnik, oferecemos a oportunidade de obter conhecimentos adicionais sobre os tópicos do kit de montagem. Acesse o portal diretamente através do endereço <https://www.fischertechnik.de/elearning-mechanicstatic2>.
- Con il portale di eLearning fischertechnik, offriamo la possibilità di ottenere ancora maggiori conoscenze specifiche sul tema delle costruzioni. Dalla pagina <https://www.fischertechnik.de/elearning-mechanicstatic2> puoi accedere direttamente al portale.
- На обучающем интернет-портале компании fischertechnik вы получите еще больше базовых знаний по теме конструирования. Ссылка <https://www.fischertechnik.de/elearning-mechanicstatic2> ведет прямо на портал.
- 通过 fischertechnik 线上学习门户，我们让您能有机会了解更多有关该模块主题的背景知识。可通过 <https://www.fischertechnik.de/elearning-mechanicstatic2> 直接前往该门户。



- Werde Mitglied im kostenlosen fischertechnik Fan Club und nutze die Vorteile. Melde dich hierzu einfach unter [www.fischertechnik.de/FanClub](http://www.fischertechnik.de/FanClub) an.
- Become a member of the free fischertechnik fan club and take advantage of the benefits. Simply register at [www.fischertechnik.de/FanClub](http://www.fischertechnik.de/FanClub)
- Deviens membre du Fan club fischertechnik gratuit et profite de nombreux avantages. Il suffit de t'inscrire sur [www.fischertechnik.de/FanClub](http://www.fischertechnik.de/FanClub).
- Word lid van de gratis fischertechnik Fan Club en maak gebruik van de voordelen. Meldt u hiervoor aan op [www.fischertechnik.de/FanClub](http://www.fischertechnik.de/FanClub).
- Hazte miembro del club de aficionados gratuito de fischertechnik y disfruta de todas las ventajas. Regístrate en [www.fischertechnik.de/FanClub](http://www.fischertechnik.de/FanClub).
- Torne-se um membro do fã-clube da Fischertechnik gratuitamente e desfrute de todas as vantagens. Basta registrar-se em [www.fischertechnik.de/FanClub](http://www.fischertechnik.de/FanClub).
- Diventa membro del fan club gratuito di fischertechnik e sfrutta tutti i vantaggi. Basta registrarsi a [www.fischertechnik.de/FanClub](http://www.fischertechnik.de/FanClub).
- Стань членом бесплатного фан-клуба fischertechnik и пользуйся преимуществами. Для этого просто зарегистрируйся по адресу [www.fischertechnik.de/FanClub](http://www.fischertechnik.de/FanClub).
- x免费加入慧鱼粉丝俱乐部 (fischertechnik Fan Club) 会员，即刻享受会员福利。只需前往 [www.fischertechnik.de/FanClub](http://www.fischertechnik.de/FanClub) 完成注册即可。

**Inhalt**  
**Contents**  
**Contenu**

Einzelteilübersicht / Spare parts list / Liste des pièces détachées / Onderdelenoverzicht / Lista da piezas / Resumo de peça individual / Singoli componenti / Перечень деталей / 零件概览 ..... 4

Montagetipps / Tips for assembly / Tuyaux pour le montage / Montagetips / Consejos para el montaje / "Dicas" para montagem / Consigli per il montaggio / Советы по сборке / 装配建议 ..... 6



Schranke / Bar / Barrière / Slagboom / Barrera / Barriera / Barreira / Шлагбаум / 栅栏 ..... 8



Drehtisch / Turntable / Plateau rotatif / Draaitafel / Mesa giratoria / Mesa rotatória / Tavola rotante / Поворотный стол / 转台 ..... 11



Kurbelgetriebe 1 / Crank gear 1 / Mécanisme à manivelle 1 / Krukasoverbrenging 1 / Mecanismo de manivela 1 / Engrenagem de manivela 1 / Ingranaggio a manovella 1 / Кривошипный механизм 1 / 曲柄传动机构 1 ..... 15



Kurbelgetriebe 2 / Crank gear 2 / Mécanisme à manivelle 2 / Krukasoverbrenging 2 / Mecanismo de manivela 2 / Engrenagem de manivela 2 / Ingranaggio a manovella 2 / Кривошипный механизм 2 / 曲柄传动机构 2 ..... 16



Schiefe Ebene mit Fahrzeug / Inclined plane with vehicle / Plan incliné avec véhicule / Helling met voertuig / Plano inclinado con vehículo / Rampa com veículo / Piano inclinato con veicolo / Наклонный пандус с автомобилем / 配备车辆的斜面 ..... 17



Fahrzeug 1 / Vehicle 1 / Véhicule 1 / Voertuig 1 / Vehículo 1 / Veículo 1 / Veicolo 1 / Автомобиль 1 / 1号汽车 ..... 23



Fahrzeug 2 / Vehicle 2 / Véhicule 2 / Voertuig 2 / Vehículo 2 / Veículo 2 / Veicolo 2 / Автомобиль 2 / 2号汽车 ..... 25



Fahrzeug 3 / Vehicle 3 / Véhicule 3 / Voertuig 3 / Vehículo 3 / Veículo 3 / Veicolo 3 / Автомобиль 3 / 3号汽车 ..... 27



Fahrzeug 4 / Vehicle 4 / Véhicule 4 / Voertuig 4 / Vehículo 4 / Veículo 4 / Veicolo 4 / Автомобиль 4 / 4号汽车 ..... 29



Bollerwagen / Handcart / Chariot à main / Bolderkar / Carro / Carrinho de puxar / Carretto / Тележка / 儿童手拉车 ..... 31

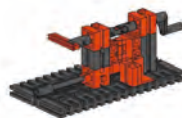

Kardangelenk / Cardan joint / Joint de cardan / Cardano-verbrenging / Articulación cardán / Junta universal / Giunto cardanico / Карданный шарнир / 万向节 ..... 33

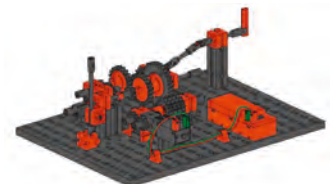

Schaltgetriebe / Gearbox / Mécanisme intermittent / Schakeloverbrenging / Cambio de velocidades / Caixa de câmbio / Cambio meccanico / Коробка передач / 变速器 ..... 35

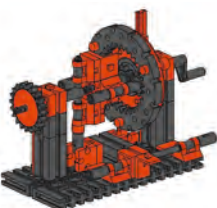

Planetengetriebe / Planetary gear / Engrenage planétaire / Planeetwieloverbrenging / Engranaje planetario / Engrenagem planetária / Rotismo epicicloidal / Планетарный редуктор / 行星齿轮机构 ..... 40



Kegelradgetriebe / Bevel gear / Engrenage à pignon conique / Conische tandwieloverbrenging / Engranaje de ruedas cónicas / Engrenagem cônica / Ingranaggio conico / Конический редуктор / 锥齿轮传动机构 ..... 43

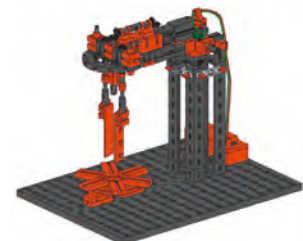

Küchenmaschine / Kitchen appliance / Robot ménager / Keukenmachine / Máquina de cocina / Máquinas de cozinha / Robot da cucina / Кухонный комбайн / 电动厨具 ..... 44

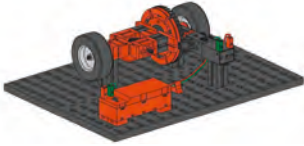

Differentialgetriebe / Differential gear / Engrenage différentiel / Differentieel / Engranaje diferencial / Transmissão diferencial / Differenziale / Дифференциал / 差速机构 ..... 49



Scherenhubtisch mit Lenkung / Scissor lift table with steering system / Table élévatrice à ciseaux avec renvoi de direction / Schaarheftafel met stuur / Mesa elevadora de tijera con dirección / Mesa elevatória de tesouras com direção / Elevatore a pantografo con sterzo / Ножничный подъёмный стол на тележке / 带转向机构的剪式升降台 ..... 52

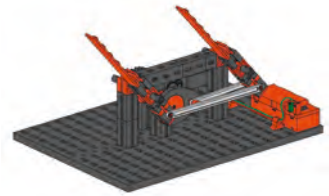

Scheibenwischer / Windshield wiper / Essuie-glace / Ruitenwischer / Limpiaparabrisas / Para-brisas / Tergicristallo / Стеклоочистители / 刮雨器 ..... 56



Viergelenkette / Four-bar chain / Chaîne cinématique à quatre joints articulés / Vierscharniersmechanisme / Mecanismo de cuatro articulaciones / Corrente de quatro articulações / Catena a quattro articolazioni / Четырехзвенный шарнирный механизм / 四活节链 ..... 60

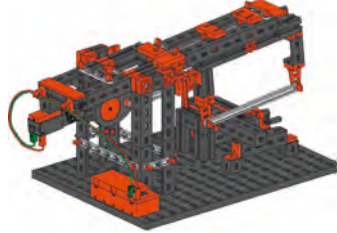

Bügelsäge / Power hacksaw machine / Scie à archet / Beugelzaag / Sierra de arco / Serra de arco / Seghetto ad arco / Ножовка / 弓锯 ..... 61

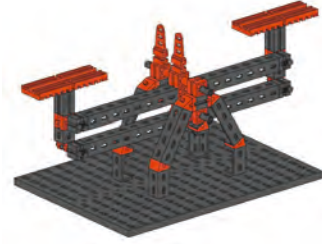

Balkenwaage / Beam and scales / Crochet-basculé / Balansweegschaal / Balanza de brazos / Balança de pratos / Bilancia a braccio / Весы с коромыслом / 天平 ..... 68



Waage mit Laufgewicht / Scales with sliding weight / Balance à poids mobile / Weegschaal met schuifgewicht / Balanza con pesa corrediza / Balança com peso cursor / Bilancia con cursore / Весы с подвижным грузом / 带滑动秤锤的天平 ..... 72

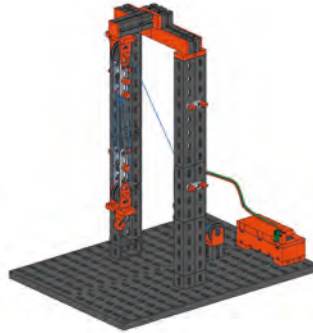

Flaschenzug / Lifting tackle / Palan / Takel / Polipasto / Talha / Paranco / Таль / 滑轮组 ..... 77



Tisch / Table / Table / Tafel / Mesa / Mesa / Tavola / Стол / 工作台 ..... 87



Bockleiter / Double ladder / Echelle double / Trapladder / Escalera de tijera / Escada de cavalete / Scala a libro / Стремянка / 人字梯 ..... 90



Balkenbrücke / Girder Bridge / Pont à poutres droites / Balkenbrug / Puente de vigas / Ponte de travessa / Ponte a trave / Балочный мост / 梁式桥 ..... 93



Brücke mit Unterzug / Bridge with Underbeam / Pont avec solive transversale / Brug met onderlagbalken / Puente con viga maestra / Ponte com viga de sustentação inferior / Ponte con trave inferiore / Мост с нижней рамой / 带下托梁的桥 ..... 95



Brücke mit Oberzug / Bridge with Upperbeam / Pont à membrure supérieure transversale / Brug met bovenslagbalken / Puente con viga testera / Ponte com viga de sustentação superior / Ponte con trave superiore / Мост с верхней рамой / 带上托梁的桥 ..... 97



Schrägseilbrücke / Cable-stayed bridge / Pont à haubans / Tuibrug / Puente atirantado / Ponte estaiada / Ponte con funi di sospensione / Вантовый мост / 斜拉桥 101

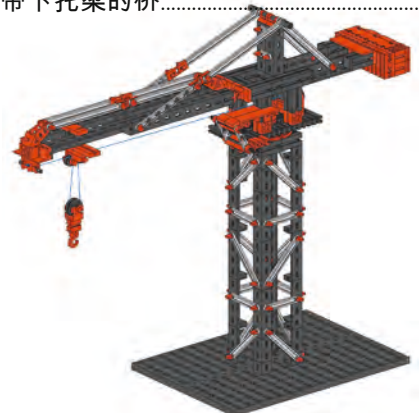











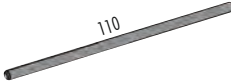













Kran / Crane / Grue / Kraan / Grúa / Guindaste / Gru / Кран / 起重机 ..... 105

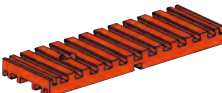





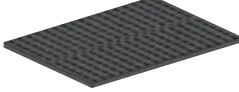







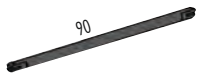

**Einzelteilübersicht**  
**Spare parts list**  
**Liste des pièces détachées**

**Onderdelenoverzicht**  
**Lista da piezas**  
**Lista de peças**

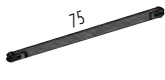































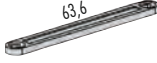



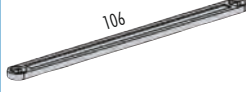

**Singoli componenti**  
**Перечень деталей**  
**零件概览**

	31 010 4 x
	31 011 4 x
	31 019 1 x
	31 021 2 x
	31 022 1 x
	31 031 2 x
	31 058 3 x
	31 060 10 x
	31 061 3 x
	31 078 1 x
	31 082 1 x
	31 426 5 x
	31 436 11 x
	31 597 6 x
	31 667 4 x
	31 690 5 x
	31 843 2 x

	31848 3 x
	31 915 1 x
	31 916 1 x
	31 982 13 x
	31 983 2 x
	32 064 11 x
	32 085 1 x
	32 859 2 x
	32 869 1 x
	32 870 4 x
	32 879 13 x
	32 881 10 x
	32 882 4 x
	32 913 4 x
	32 985 1 x
	35 031 3 x
	35 033 2 x

	35 049 6 x
	35 061 2 x
	35 062 2 x
	35 063 4 x
	35 064 2 x
	35 065 3 x
	35 066 2 x
	35 069 1 x
	35 070 1 x
	35 073 6 x
	35 087 3 x
	35 088 1 x
	35 113 1 x
	35 129 2 x
	35 466 1 x
	35 694 1 x
	35 695 4 x

	35 797 2 x
	35 945 6 x
	35 969 2 x
	35 971 4 x
	35 972 2 x
	35 998 2 x
	36 227 2 x
	36 248 38 x
	36 264 1 x
	36 293 4 x
	36 323 60 x
	36 324 6 x
	36 334 3 x
	36 819 7 x
	36 920 8 x
	36 921 16 x
	36 922 5 x

	36 950 7 x		37 926 3 x		38 428 5 x		160 542 8 x
	36 977 1 x		38 225 1 x		38 464 4 x		160 543 12 x
	37 237 12 x		38 240 4 x		38 472 1 x		160 544 2 x
	37 238 2 x		38 242 1 x		68 535 1 x		160 545 4 x
	37 468 8 x		38 245 2 x		116 913 4 x		160 546 4 x
	37 527 1 x		38 246 3 x		135 719 1 x		160 547 12 x
	37 636 2 x		38 258 2 x		137 096 1 x		160 548 12 x
	37 679 7 x		38 260 4 x		153 669 2 x		181 583 2 x
	37 858 1 x		38 414 2 x		156 105 4 x		181 584 2 x
	37 925 1 x		38 423 2 x		160 541 4 x		

**Montagetipps**  
**Tips for assembly**  
**Tuyaux pour le montage**

**Montagetips**  
**Consejos para el montaje**  
**"Dicas" para montagem**

**Consigli per il montaggio**  
**Советы по сборке**  
**装配建议**

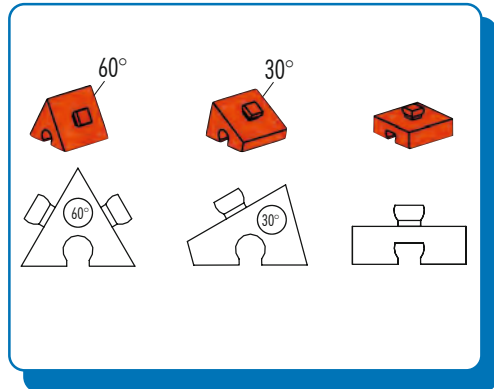
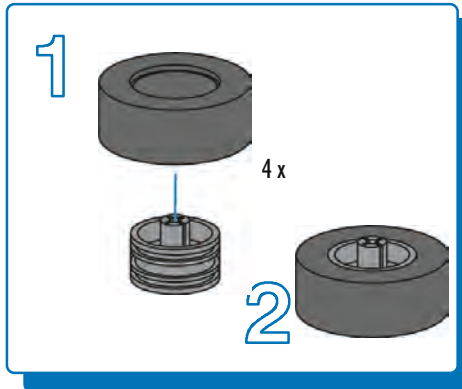
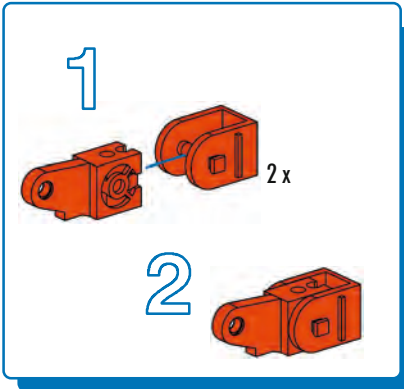
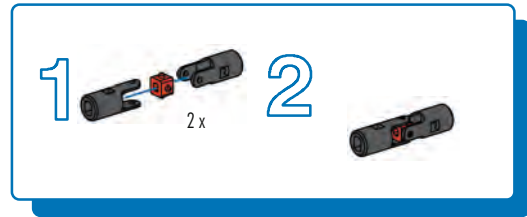
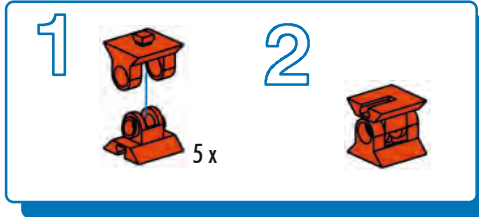
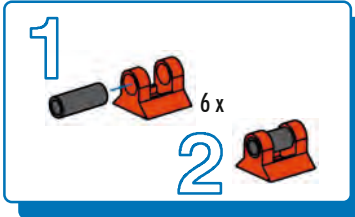

Kabel und Stecker  
Plugs and cables  
Fiches et des câbles

Stekkers en cables  
Enchufes en cables  
Cabos e contatos

Cavi e connettori  
Провода и штекеры  
电缆和插头

0 3 cm

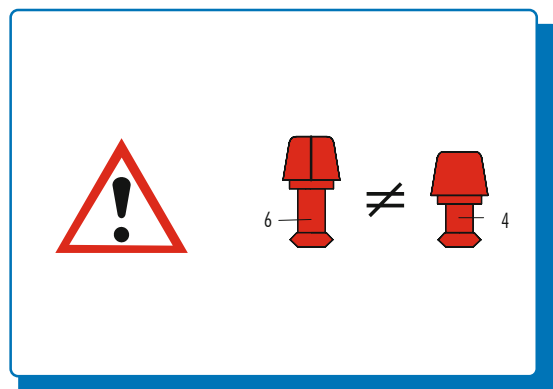
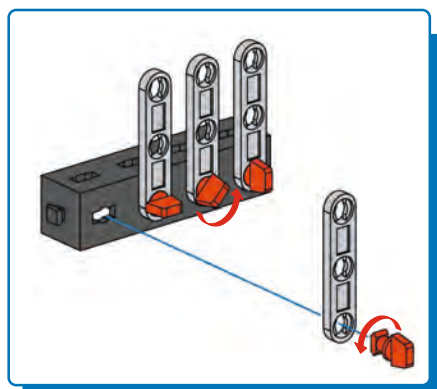
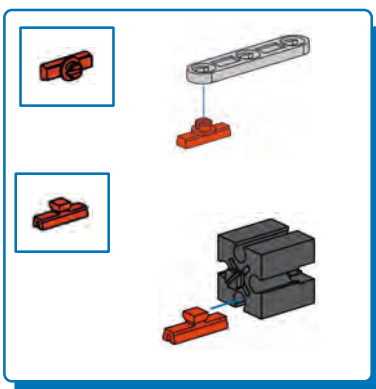

**Sicherheitshinweise**  
**Safety Information**  
**Consignes de sécurité**

**Veiligheidsrichtlijnen**  
**Indicaciones de seguridad**  
**Observações sobre segurança**

**Informazioni per la sicurezza**  
**Указания по технике безопасности**  
**安全指南**

- Alle Einzelteile, insbesondere bewegliche Teile sind falls notwendig zu warten und zu reinigen.
- All components, especially moving parts, should be maintained and cleaned as necessary.
- Toutes les pièces détachées et en particulier les pièces mobiles, sont, si nécessaire, à entretenir et à nettoyer.
- Alle onderdelen, vooral de bewegende delen, kunnen, indien noodzakelijk, onderhouden en gereinigd worden.
- Es necesario limpiar y mantener en buen estado todas las diferentes piezas - especialmente las piezas móviles.
- Caso necessário, todas as peças individuais, especialmente peças móveis, tem que ser submetidas à manutenção e ser limpas.
- Se necessario, tutti i singoli componenti, soprattutto le parti mobili, si devono eventualmente sottoporre a manutenzione e pulizia.
- Все детали, особенно подвижные, требуют ухода и чистки.
- 必要时应保养和清洁所有零件，尤指运动部件。



# Sicherheitshinweise Safety Information Consignes de sécurité

# Veiligheidsrichtlijnen Indicaciones de seguridad Observações sobre segurança

# Informazioni per la sicurezza Указания по технике безопасности 安全指南

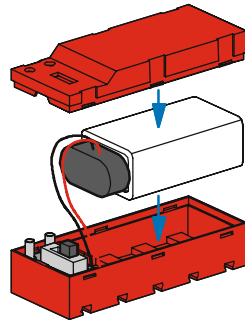

Batterie ist nicht Inhalt der Packung  
Battery not included  
Batterie non comprise  
De batterij wordt niet meegeleverd  
La batería no está incluida en el suministro  
A bateria não é o conteúdo da embalagem  
La batteria non è inclusa nella confezione  
Батарея в комплект не входит  
包装中不含电池

## 1 Batterie 9Volt-Block Alkaline

- Nicht wiederaufladbare Batterien dürfen nicht geladen werden
- Aufladbare Batterien dürfen nur von Erwachsenen geladen werden
- Aufladbare Batterien sind aus dem Batteriehalter herauszunehmen, bevor sie geladen werden.
- Batterien müssen mit der richtigen Polarität eingelegt werden.
- Leere Batterien müssen aus dem Spielzeug herausgenommen werden
- Die Anschlussklemmen dürfen nicht kurzgeschlossen werden.
- Verbrauchte Batterien dem Sondermüll zuführen.
- Drähte nicht in Steckdose einführen!
- Ladegerät regelmäßig auf Schäden überprüfen. Bei einem Schaden darf das Ladegerät bis zur vollständigen Reparatur nicht mehr verwendet werden.

## 9V rechargeable battery

- Do not attempt to charge NON-rechargeable batteries.
- Rechargeable batteries are only to be charged by adults.
- Take rechargeable batteries out of the battery tray before charging them.
- Insert batteries with the correct polarity.
- Remove dead batteries from the toy.
- Do not short circuit the connecting terminals!
- Discard spent dry cells at special waste disposal centre.
- Do not insert the wires into an outlet!
- Regularly inspect battery charger for damage. If the battery charger has been damaged, it should not be used further until fully repaired.

## pile 9V

- Il est interdit de recharger des piles qui ne sont pas des accumulateurs
- Le chargement des accumulateurs doit toujours se faire par des adultes
- Retirer les accumulateurs du support de pile avant de les recharger.
- Veiller à la polarité correcte lors de la mise en place des piles.
- Retirer impérativement les piles ou accumulateurs vides du jouet.
- Il est interdit de court-circuiter les bornes de raccordement.
- Jeter les piles usagées dans un conteneur spécial réservé à cet effet.
- Ne pas introduire les fils dans une prise !
- Contrôlez régulièrement le chargeur en vue d'éventuelles détériorations
- En cas de détérioration, il est interdit d'utiliser le chargeur jusqu'à ce qu'il ait été intégralement réparé

## alkaline batterije

- Niet-oplaadbare batterijen mogen niet worden opgeladen.
- Oplaadbare batterijen mogen uitsluitend door volwassenen worden opgeladen.
- Oplaadbare batterijen moeten uit de batterijhouder worden verwijderd, voordat deze worden opgeladen.
- De batterijen moeten met de juiste polariteit worden geplaatst.
- Lege batterijen moeten uit het speelgoed worden verwijderd.
- De aansluitklemmen mogen niet worden kortgesloten.
- Afgevoeren gebruikte batterijen bij het klein chemisch afval (KCA).
- Geen draden in de contactdoos steken!
- Laadtoestel regelmatig controleren op schade. Bij schade mag het laadtoestel niet meer gebruikt worden tot het volledig hersteld is.

## pila alcalina bloque de 9 Voltios

- Las pilas no recargables no pueden ser cargadas
- Las pilas recargables sólo pueden ser cargadas por un adulto
- Las pilas recargables deben ser extraídas del compartimiento de pilas antes de que sean cargadas.
- Las pilas deben ser colocadas con la polaridad correcta.
- Las pilas descargadas deben ser extraídas del juguete
- Los bornes de conexión no pueden ser puestos en cortocircuito.
- Retirar las baterías viejas, desechándolas en un depósito de basuras especiales.
- No introducir hilos en la toma de corriente!
- Comprobar con regularidad si el cargador presenta daños. En caso de presentar daños, el cargador no debe volver a ser utilizado hasta que esté completamente reparado.

## Bateria alcalina de bloco de 9 V

- Pilhas não recarregáveis não devem ser novamente carregadas.
- Pilhas recarregáveis somente devem ser recarregadas por adultos.
- Pilhas recarregáveis devem ser retiradas do compartimento de pilhas antes de serem carregadas.
- As pilhas devem ser colocadas com a polaridade correta.
- As pilhas descarregadas devem ser retiradas do brinquedo.
- Os terminais de conexão não devem ser curto-circuitados.
- Eliminar as baterias esgotadas como desperdício perigoso
- Nunca introduzir fios na tomada!
- Verificar regularmente se o carregador apresenta danos. Em caso de dano, o carregador não deverá ser utilizado enquanto não estiver plenamente consertado.

## 1 batteria alcalina da 9 V

- Le batterie non ricaricabili non devono essere ricaricate
- Le batterie ricaricabili devono essere ricaricate da persone adulte
- Le batterie ricaricabili si devono estrarre dal supporto prima di ricaricarle.
- Le batterie si devono inserire rispettando la polarità.
- Togliere le batterie dal giocattolo quando sono scariche
- I morsetti di allacciamento non devono essere cortocircuitati.
- Smaltire le batterie usate negli appositi contenitori per la raccolta differenziata.
- Non inserire i fili nella presa elettrica.
- Controllare periodicamente se il caricabatterie presenta dei danni. In caso di danni, il caricabatterie non deve più essere utilizzato fino alla riparazione.

## 1 алкалиновая батарейка на 9 В

- Не пытайтесь заряжать перезаряжаемые батарейки.
- Зарядку перезаряжаемых аккумуляторов разрешается выполнять только взрослым.
- Перед зарядкой перезаряжаемых аккумуляторов извлеките их из аккумуляторного отсека.
- При установке аккумуляторов на место соблюдайте полярность.
- Разряженные батарейки необходимо извлечь из игрушки.
- Не замыкайте накоротко соединительные клеммы.
- Использованные батареи утилизировать как спецотходы.
- Не вставляйте в розетку провода!
- Регулярно проверяйте зарядное устройство на отсутствие повреждений. При наличии повреждений использовать зарядное устройство до выполнения его полного ремонта не разрешается.

## 1 个 9V 的碱性方电池或

- 不得给非充电电池充电
- 只允许由成年人给充电电池充电
- 在充电前必须将充电电池从电池夹中取出。
- 必须按照正负极正确放入电池。
- 必须从玩具中取出没有电的电池
- 接线柱不允许被短路。
- 用完了的电池应作为特种垃圾处理。
- 禁止将金属丝插入插座！
- 经常检查充电器是否有损坏情况。如果充电器有损，直到完全修好为止不可以再使用。

Das Spielzeug darf nur mit einer der folgenden fischertechnik Energiequellen benutzt werden:  
Art-Nr.: 135719 Batteriehalter 9V oder Art.-Nr.: 35537 Accu Pack 8,4V.

The toy may only be used with one of the following fischertechnik energy sources:

Art No.: 135719 battery tray 9V or Art No.: 35537 Accu Pack 8.4V. You are not allowed to use 9V NiMH accu packs in this product.

L'utilisation de ce jouet n'est permis qu'avec l'une des sources d'énergie fischertechnik suivantes:  
Art. n° : 135719 support de pile 9 volts ou Art. n° : 35537 pack d'accumulateurs 8,4 volts.

Het speelgoed mag uitsluitend met een van de volgende fischertechnik energiebronnen worden gebruikt: art.nr.: 135719 batterijhouder 9V of art.nr.: 35537 accupack 8,4V

El juguete se debe utilizar únicamente con una de las siguientes fuentes de energía:  
Art. No. 135719 soporte de pila de 9V o Art. No. 35537 paquete acumulador de 8,4V.

O brinquedo somente pode ser utilizado com uma das seguintes fontes de energia da fischertechnik: art. n°: 135719 Suporte de bateria de 9 V ou art. n°: 35537 Bloco de bateria de 8,4V.

Questo giocattolo può essere utilizzato solo con le seguenti fonti di energia fischertechnik: cod. prod.: 135719 portabatteria da 9V oppure cod. prod.: 35537 confezione batterie da 8,4V.

Игрушку можно использовать только с одним из следующих источников энергии от fischertechnik: арт. №: 135719 держатель батареек 9В или арт. №: 35537 Accu Pack 8,4В

该玩具只允许使用如下的慧鱼 (fischertechnik) 能量源：商品号：135719，9V 电池夹，或者商品号：35537，8,4V 电池套件 (Accu Pack)

Achtung! Verletzungsgefahr an Bauteilen mit funktionsbedingten scharfen Kanten und Spitzen!

Caution! Be careful not to hurt yourself on components with sharp or pointed edges!

Attention! Risque de blessure sur les éléments comportant des arêtes et o pointes vives indispensables au bon fonctionnement!

Let op! U kunt zich bezeren aan bouwstenen met scherpe randen of punten!

Atención! ¡Cuidado, no te hagas daño con los componentes con bordes afilados o puntiagudos!

Atenção! Perigo de ferimentos em peças componentes com cantos vivos e pontas obrigatórios para o funcionamento !

Attenzione! Pericolo di lesioni dovute a componenti con spigoli vivi e punte per motivi funzionali!

Будьте осторожны! Об острые края деталей и и наконечники можно порезаться!

注意！因功能需要而带有锋利的棱边和尖角的部件可能会带来受伤危险！

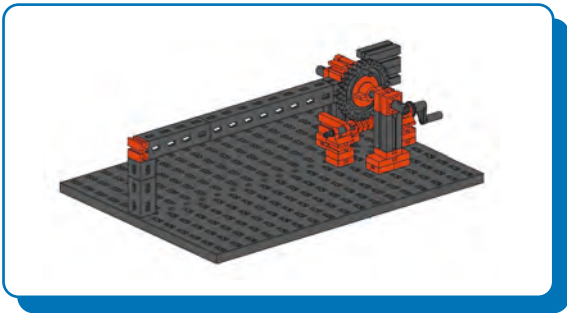

Schranke  
Bar  
Barrière

Slagboom  
Barrera  
Barriera

Barreira  
Шлагбаум  
栅栏

**1**

1x

6x

4x

1x

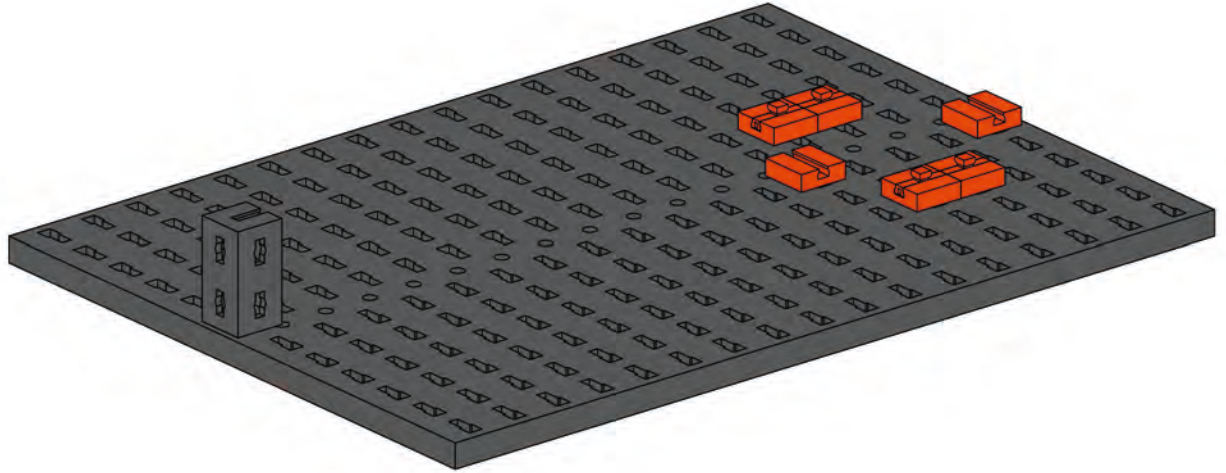

**2**

1x

1x

2x

1x

2x

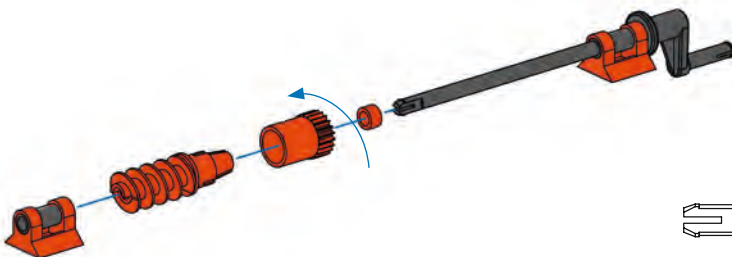
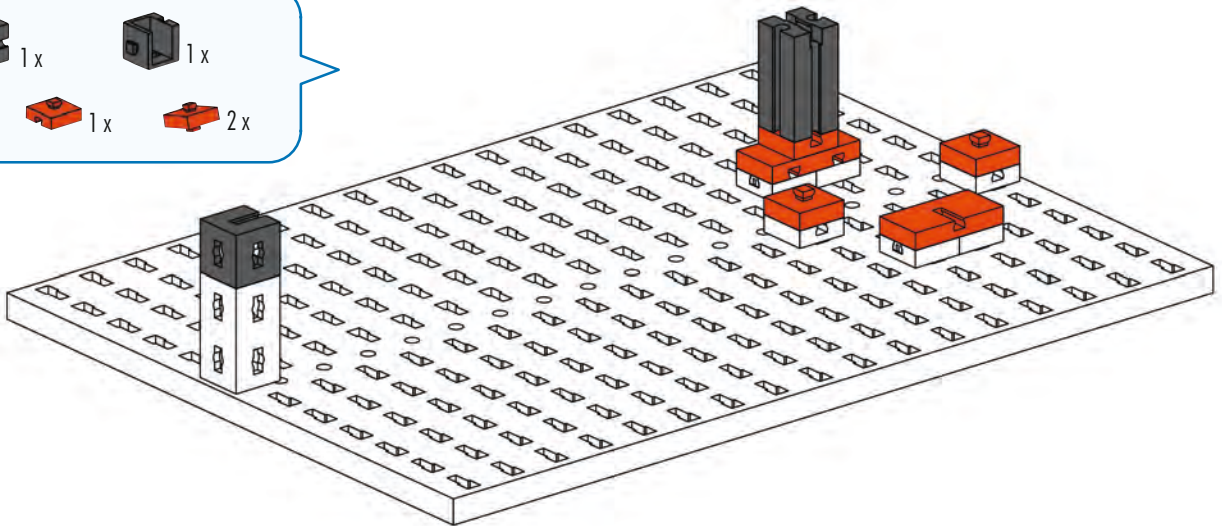

**3**

90

1x

2x

1x



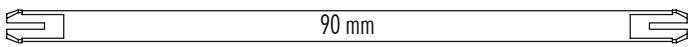

1x

1x

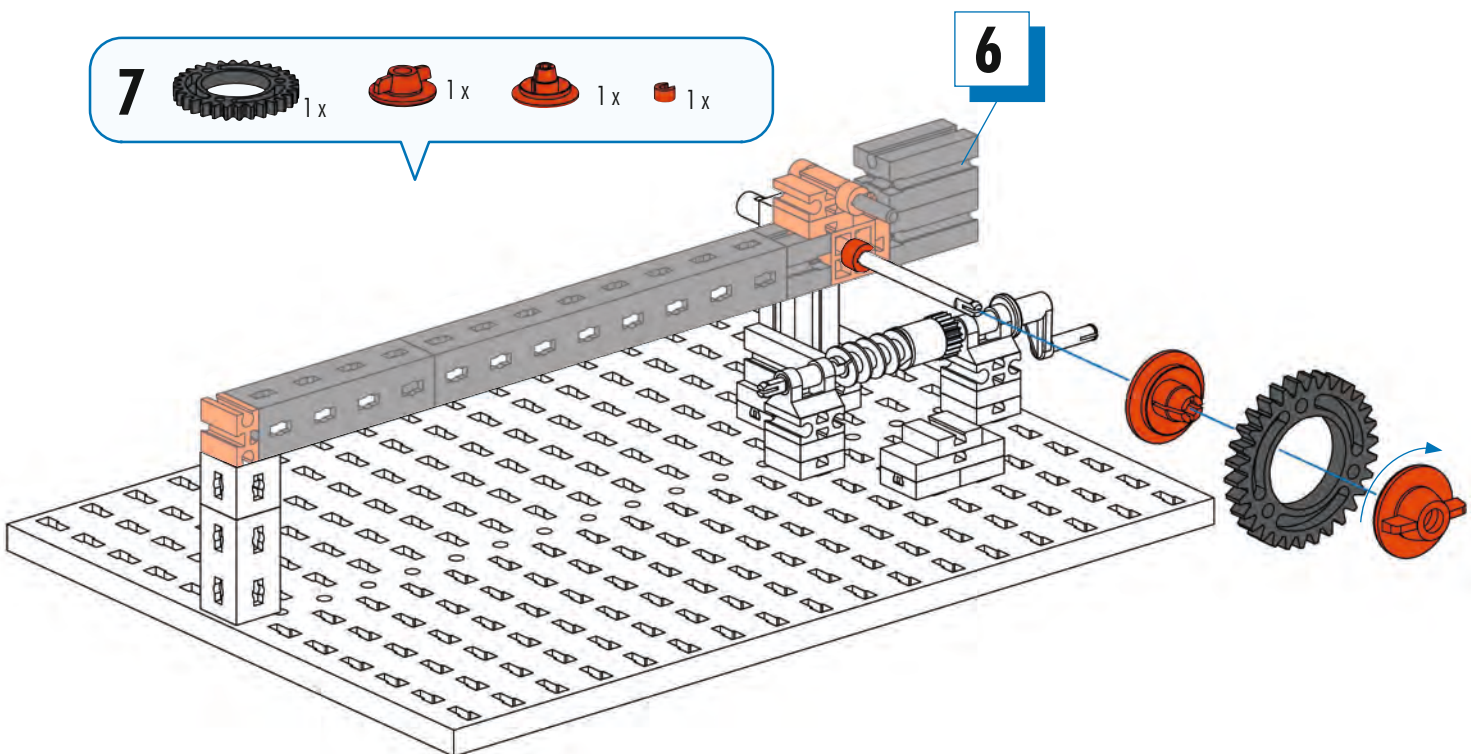
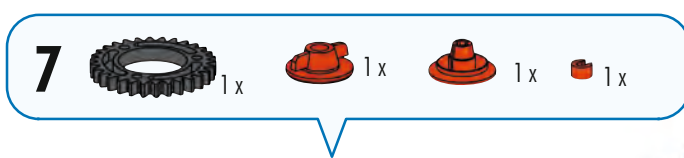
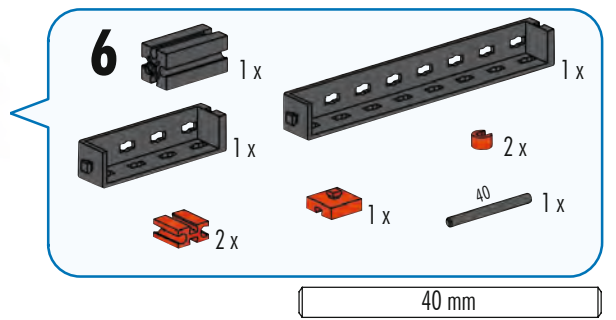
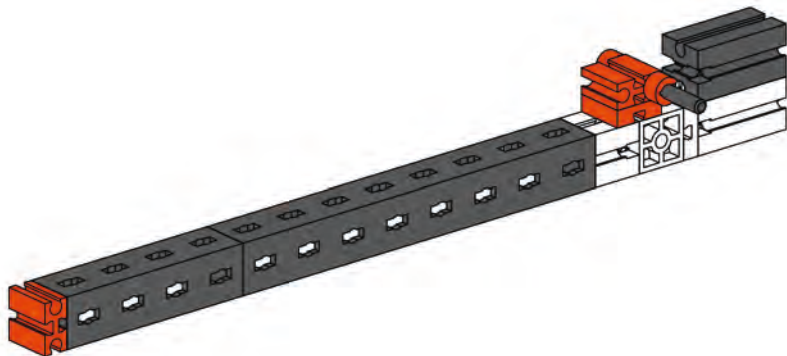
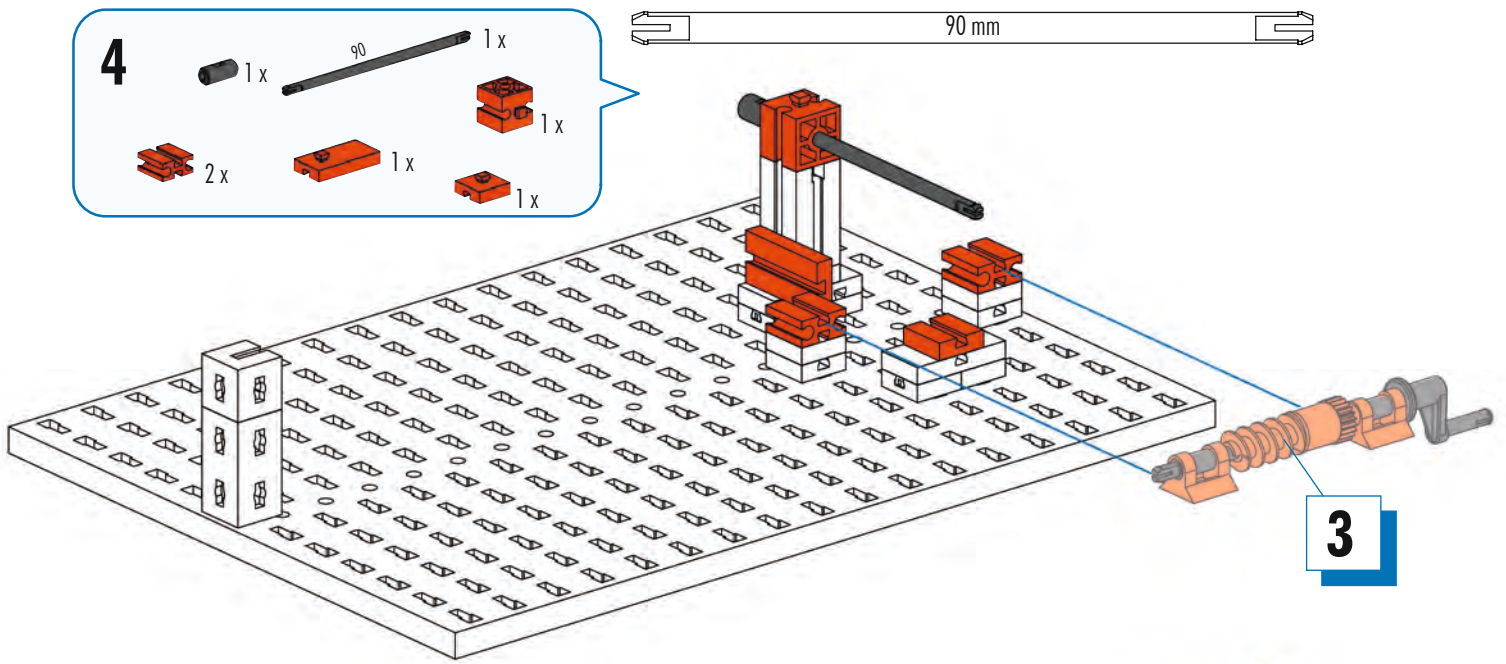
1x





- 8  1x  1x  1x  1x

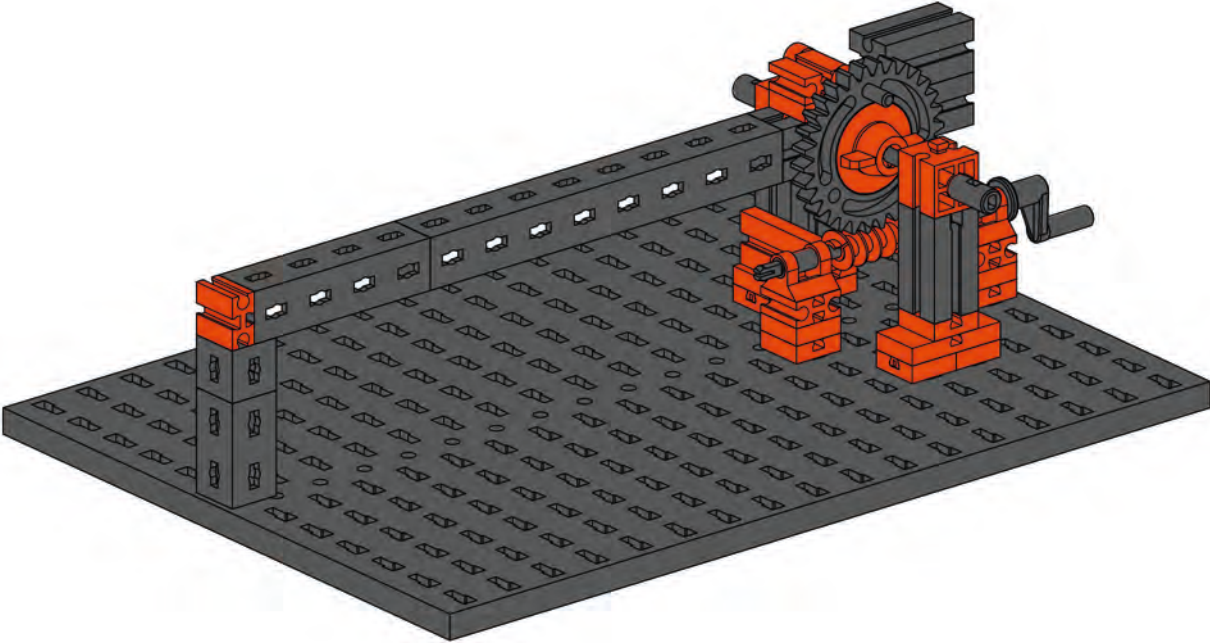
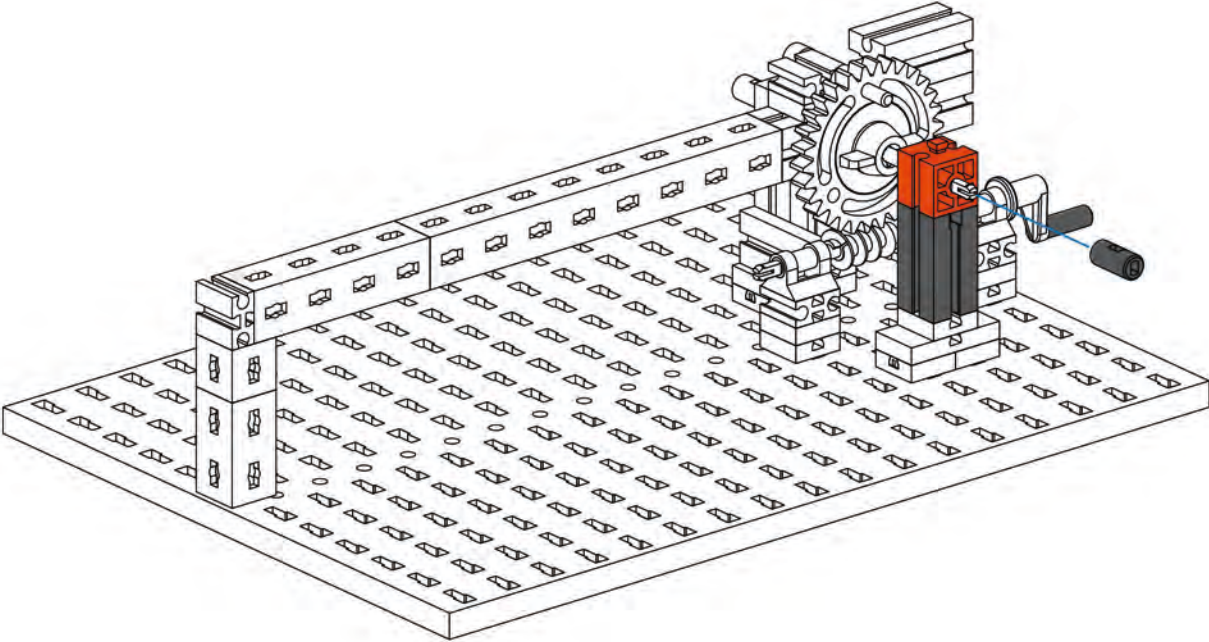

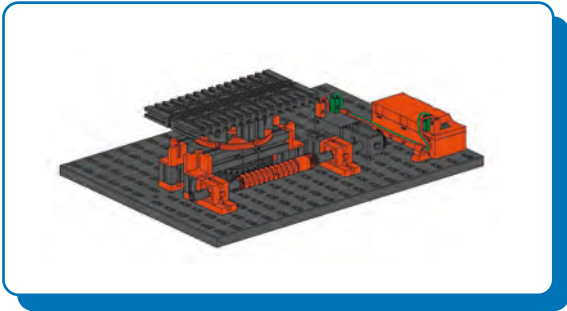

**Drehtisch**  
**Turntable**  
**Plateau rotatif**

**Draaitafel**  
**Mesa giratoria**  
**Tavola rotante**

**Mesa rotatória**  
**Поворотный стол**  
**转台**

**1**

1x  
 5x  
 2x  
 1x

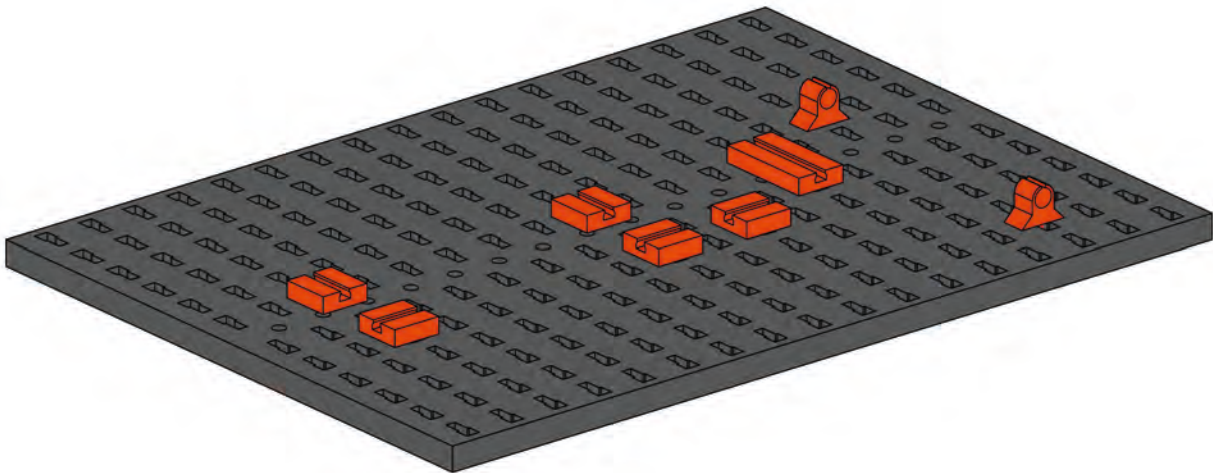

**2**

1x  
 1x

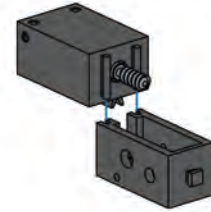

**3**

4x  
 1x  
 2x  
 1x  
 1x

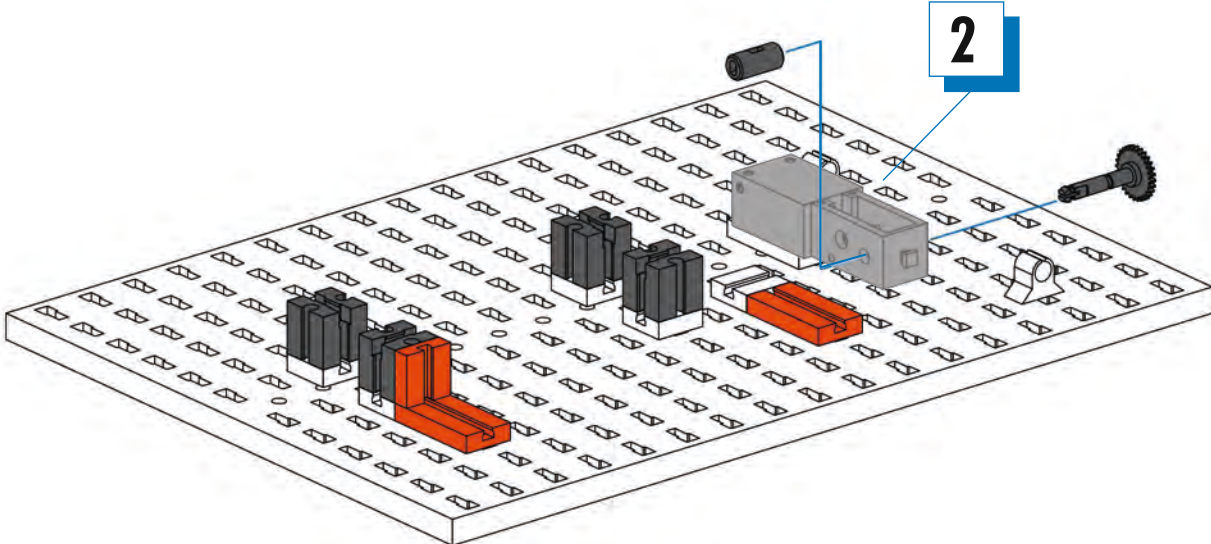

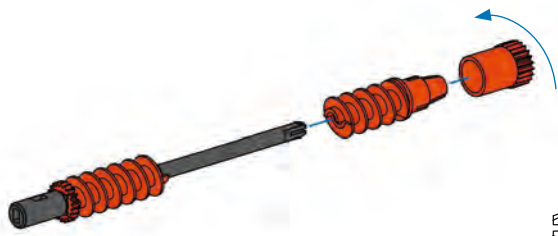

4

- 90 1x
- 1x
- 1x
- 1x
- 1x
- 1x
- 1x

90 mm

5

- 1x
- 1x
- 1x
- 4x
- 30 1x
- 1x

30 mm

4

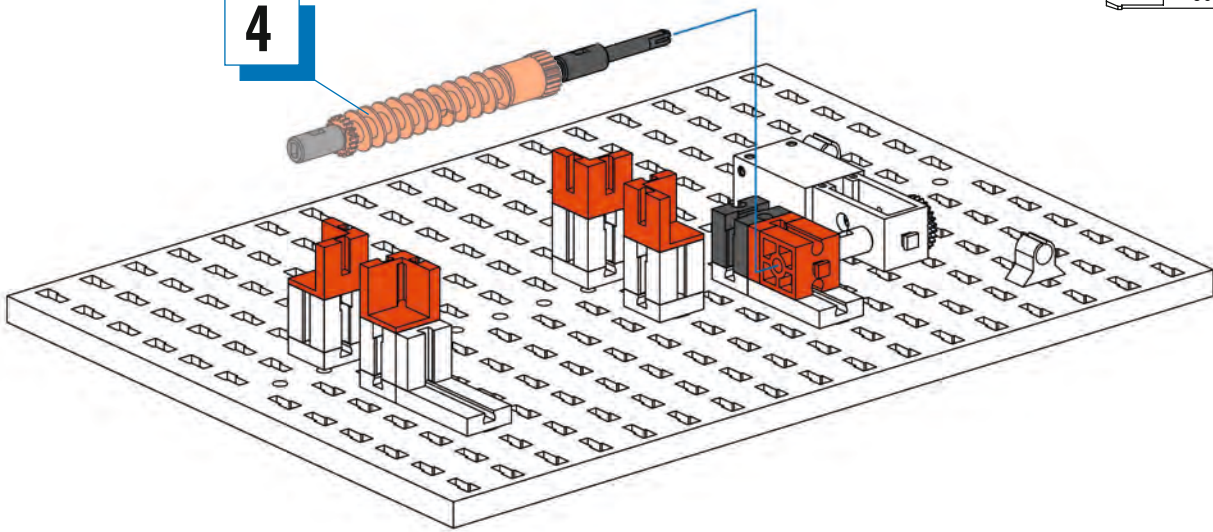

6

- 60 1x
- 1x
- 1x
- 1x

60 mm

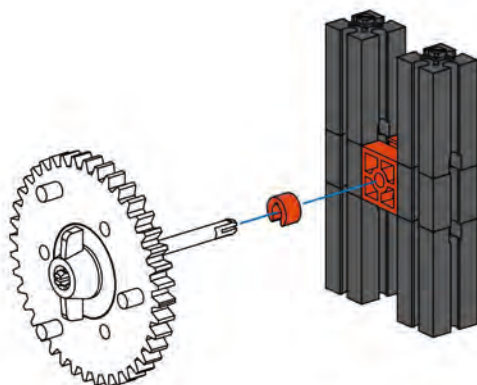
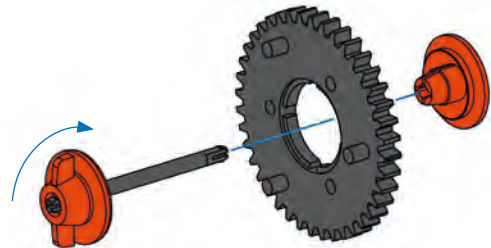



7

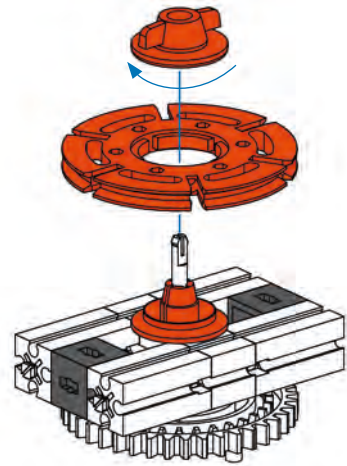

- 4x
- 2x
- 1x
- 1x

**8**  2x  1x  1x  1x

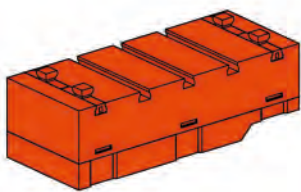
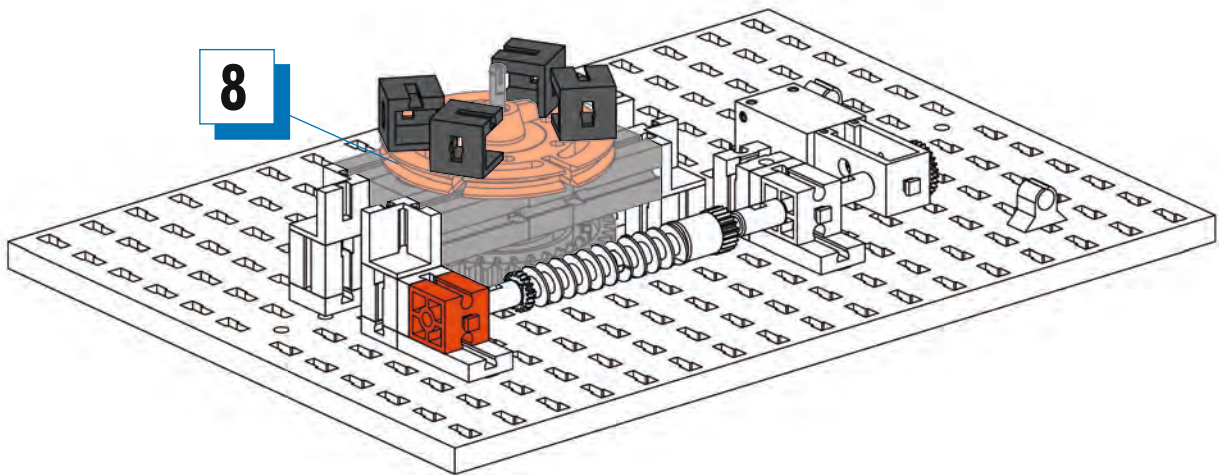

**9**  4x  1x

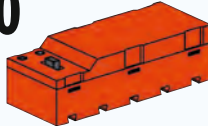

**10**  1x  4x

**11**

1 x

2 x

15 2 x

30 1 x

1 x

1 x

30 mm

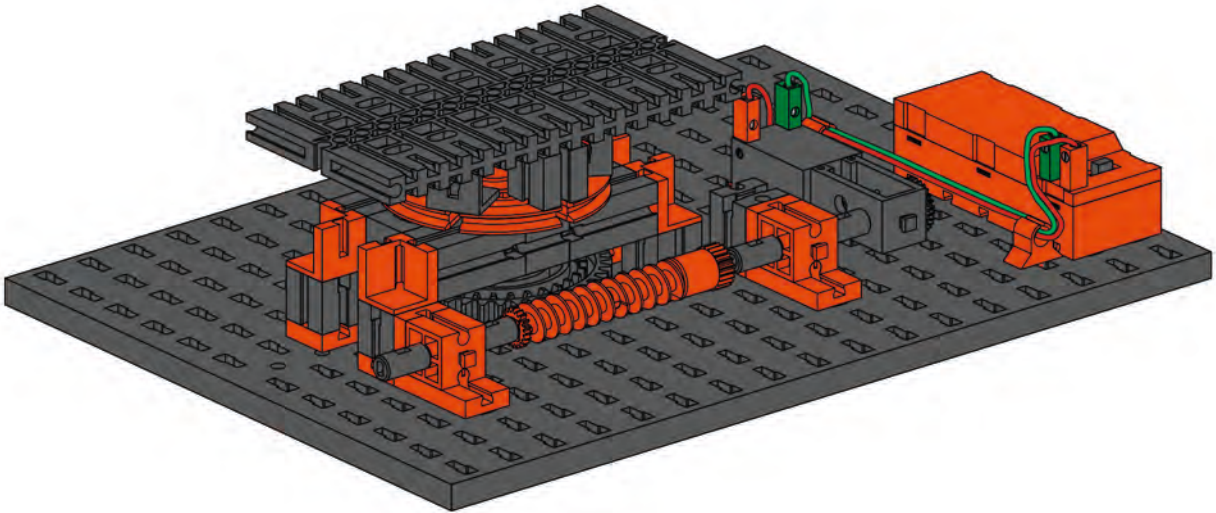
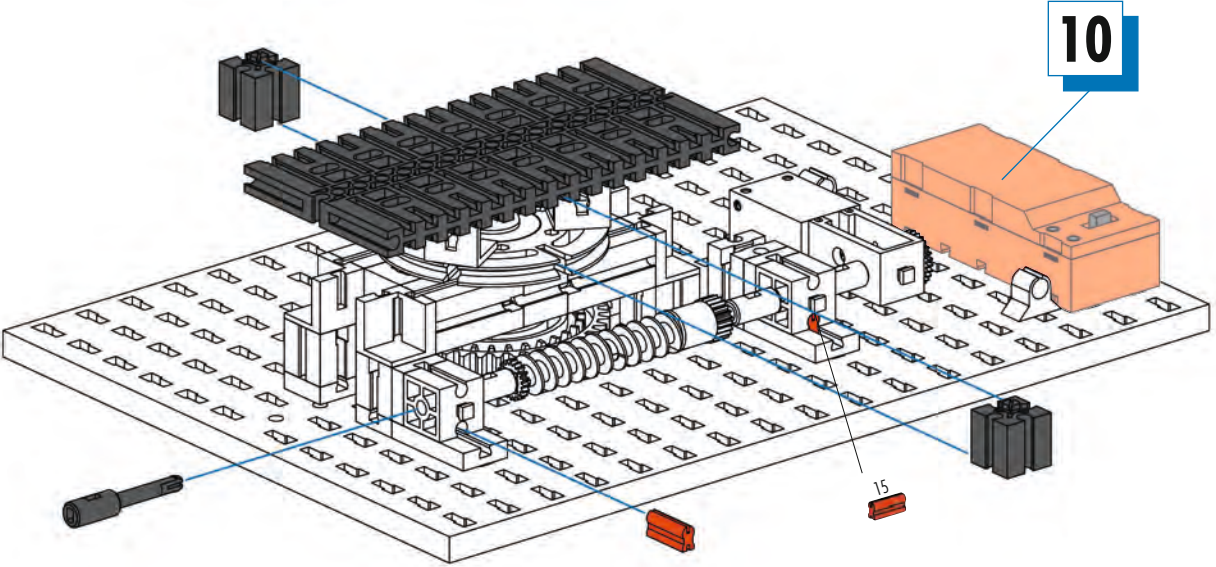



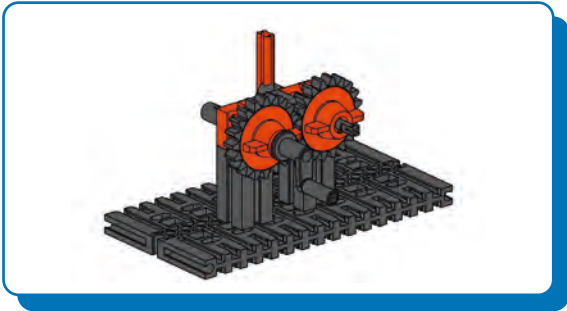

**Kurbelgetriebe 1**  
**Crank gear 1**  
**Mécanisme à manivelle 1**

**Krukasoverbrenging 1**  
**Mecanismo de manivela 1**  
**Engrenagem de manivela 1**

**Ingranaggio a manovella 1**  
**Кривошипный механизм 1**  
**曲柄传动机构 1**

**1**

30 1x      2x      1x      1x      1x      1x

45 2x      1x      1x

45 mm

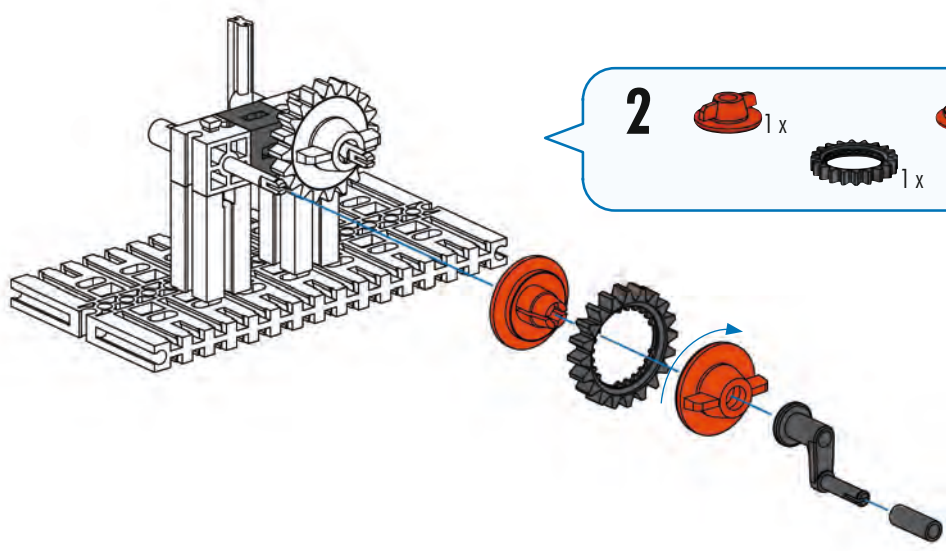
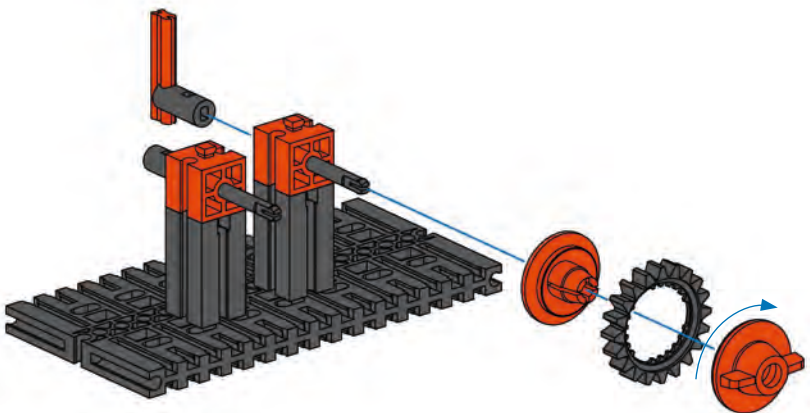

**2**

1x      1x      1x      1x      1x      1x      1x

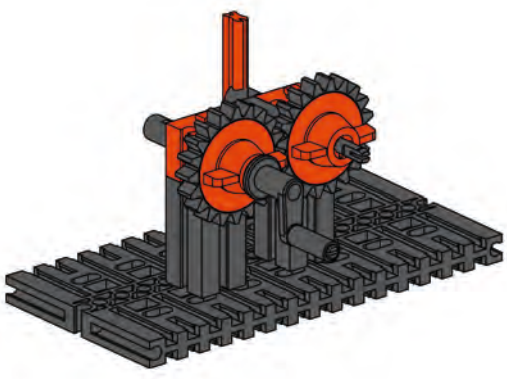

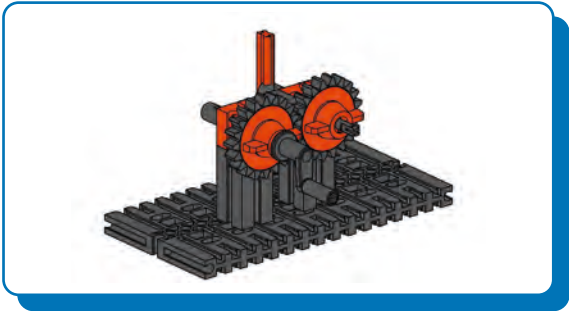

Kurbelgetriebe 2  
Crank gear 2  
Mécanisme à manivelle 2

Krukasoverbrenging 2  
Mecanismo de manivela 2  
Engrenagem de manivela 2

Ingranaggio a manovella 2  
Кривошипный механизм 2  
曲柄传动机构 2

**1**

30 1 x  
45 2 x  
45 2 x

45 mm

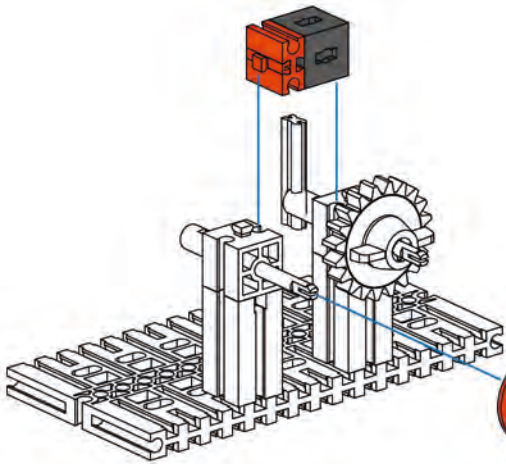
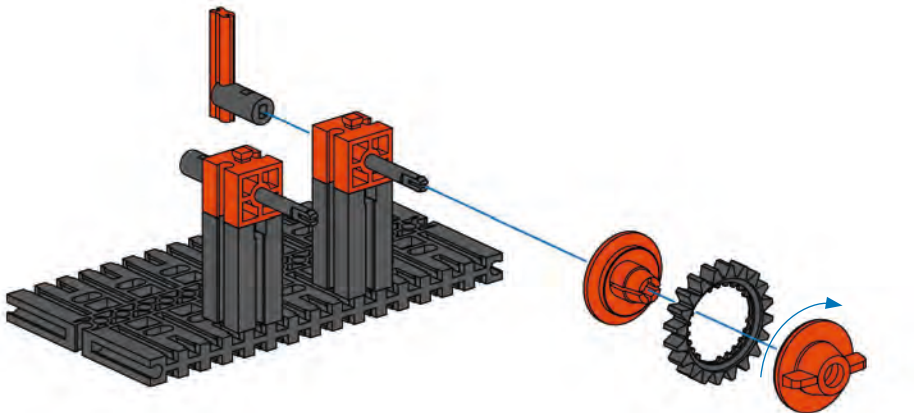

**2**

1 x  
1 x  
1 x  
1 x  
1 x  
1 x  
1 x

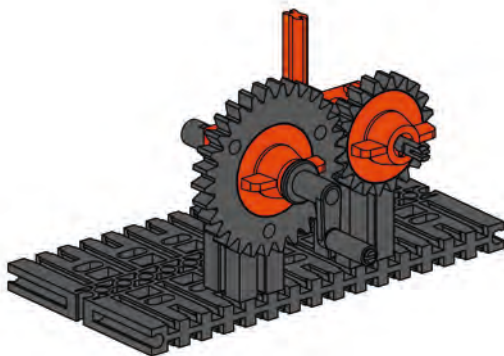
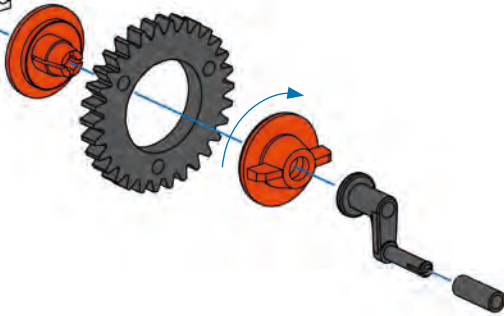

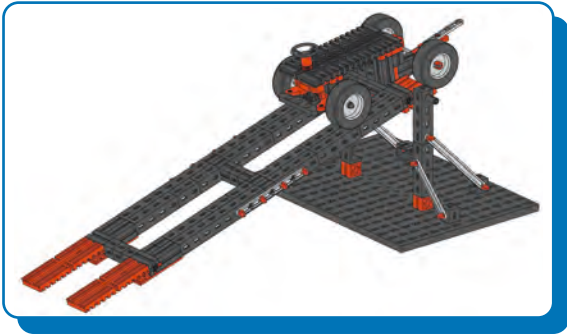

Schiefe Ebene mit Fahrzeug  
Inclined plane with vehicle  
Plan incliné avec véhicule

Helling met voertuig  
Plano inclinado con vehículo  
Rampa com veículo

Piano inclinato con veicolo  
Наклонный пандус с автомобилем  
配备车辆的斜面

**1**

- 1 x (grey Technic beam 1x15)
- 2 x (grey Technic pin)
- 2 x (orange Technic pin)
- 6 x (orange Technic pin)
- 2 x (orange Technic brick 1x2)
- 2 x (orange Technic brick 1x2 with hole)

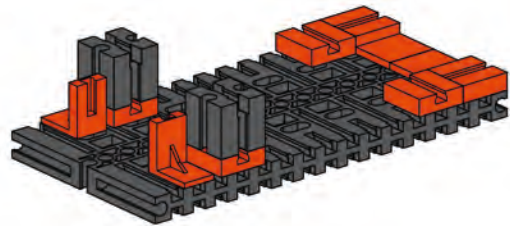

**2**

- 2 x (grey Technic beam 1x5)
- 2 x (grey Technic pin)
- 15 (grey Technic pin)
- 2 x (orange Technic pin)
- 2 x (orange Technic brick 1x2)
- 1 x (orange Technic brick 1x2 with hole)
- 2 x (orange Technic brick 1x2)

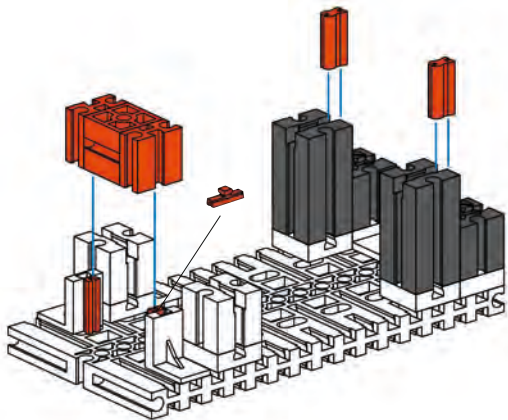

**3**

- 2 x (grey Technic beam 1x5)
- 2 x (orange Technic pin)
- 2 x (orange Technic brick 1x2)
- 1 x (grey axle 45)
- 1 x (grey bush)
- 1 x (grey steering wheel)
- 1 x (orange bush)

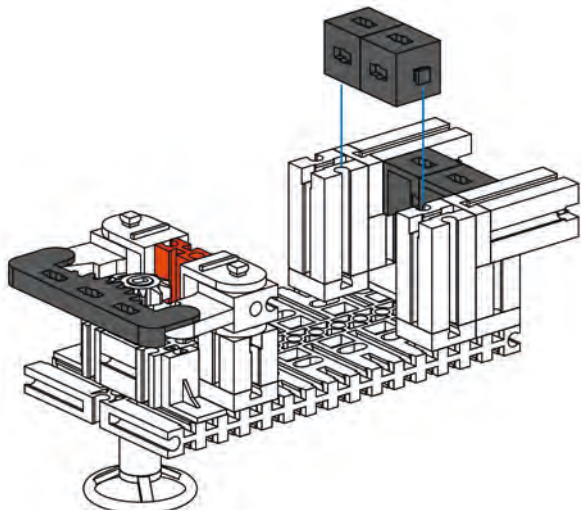
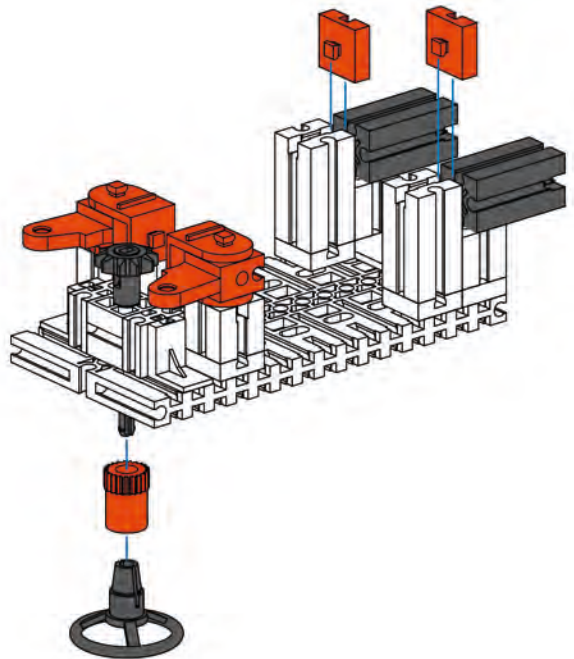
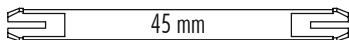

**4**

- 2 x (grey Technic pin)
- 2 x (orange Technic pin)
- 1 x (grey Technic beam 1x5)
- 1 x (orange Technic brick 1x2)

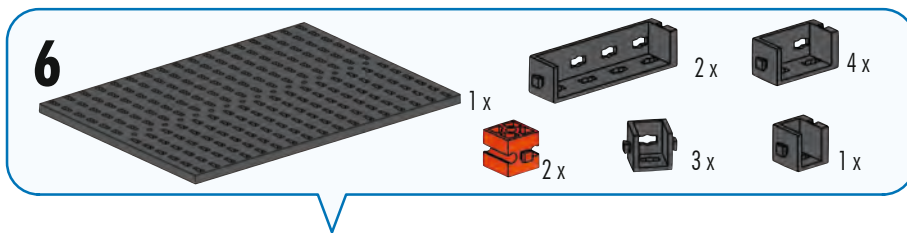
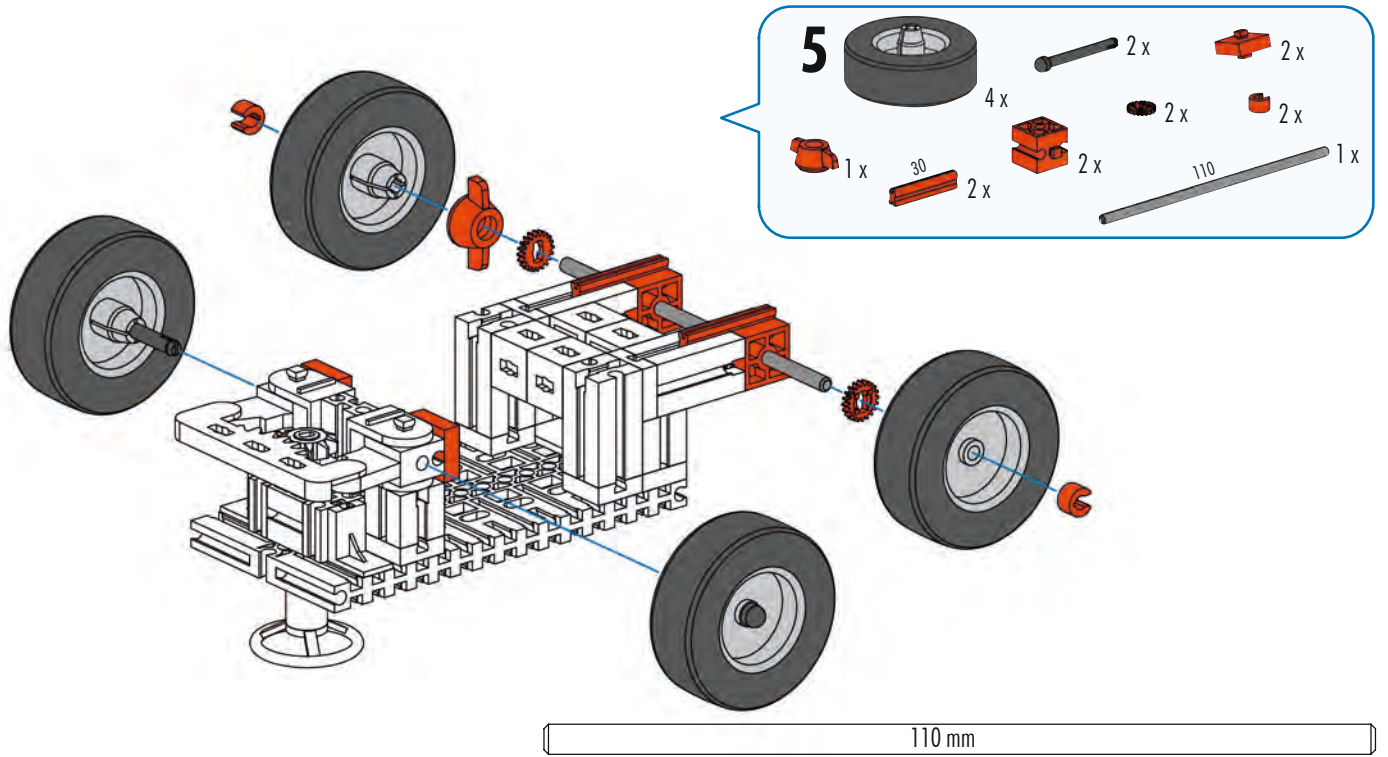

**7**

- 63,6 2x
- 106 2x
- 8x

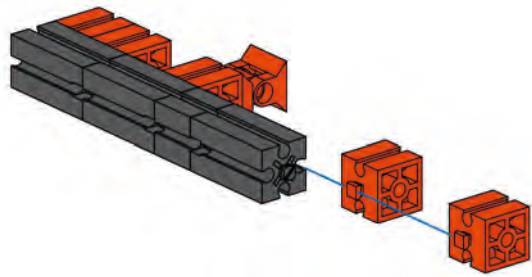
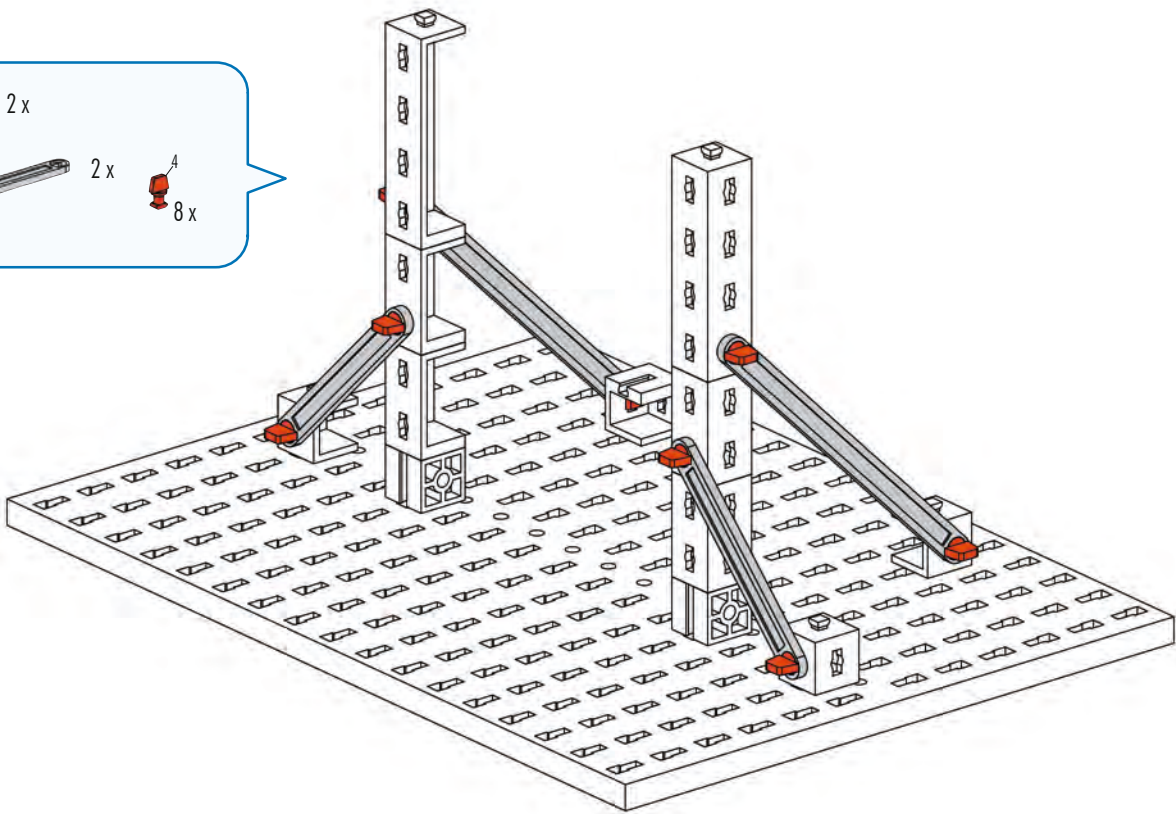

**8**

- 3x
- 1x
- 5x
- 1x

**9**

- 2x
- 8x
- 4x
- 5x
- 1x

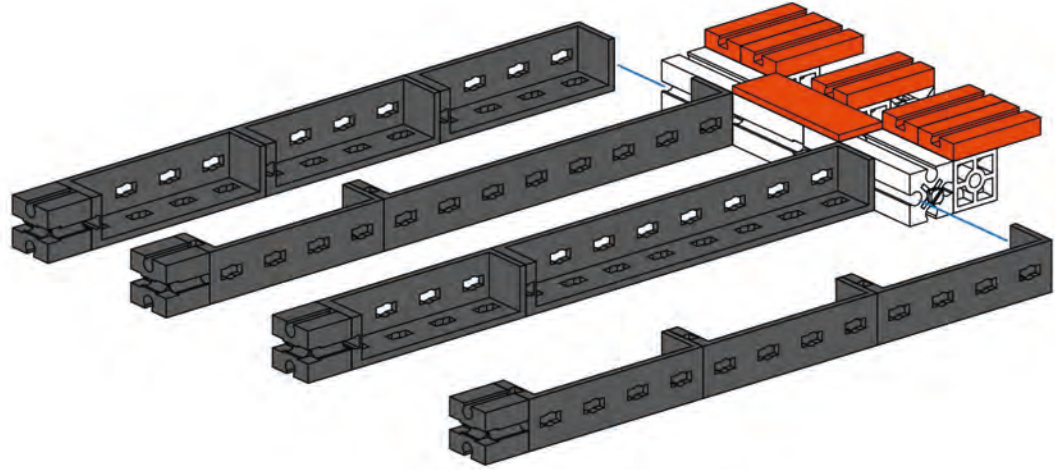

10

2x 1x 4x 15 2x

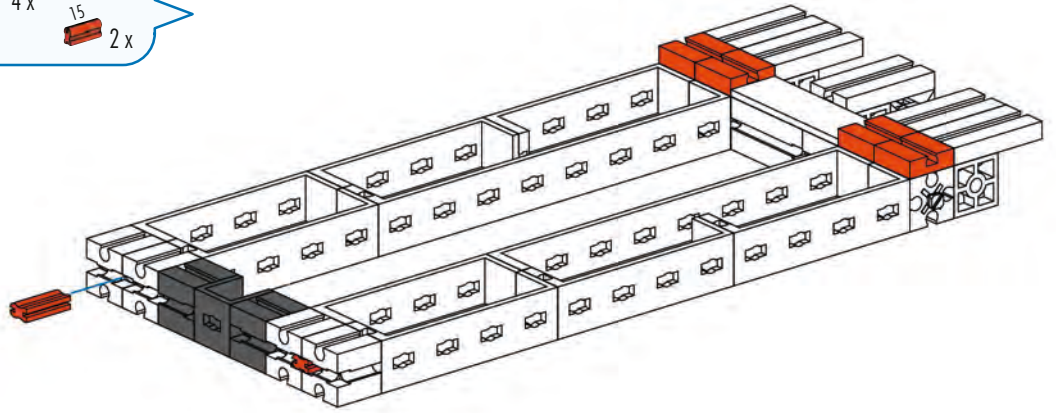

11

2x 4x 2x 2x 1x 1x

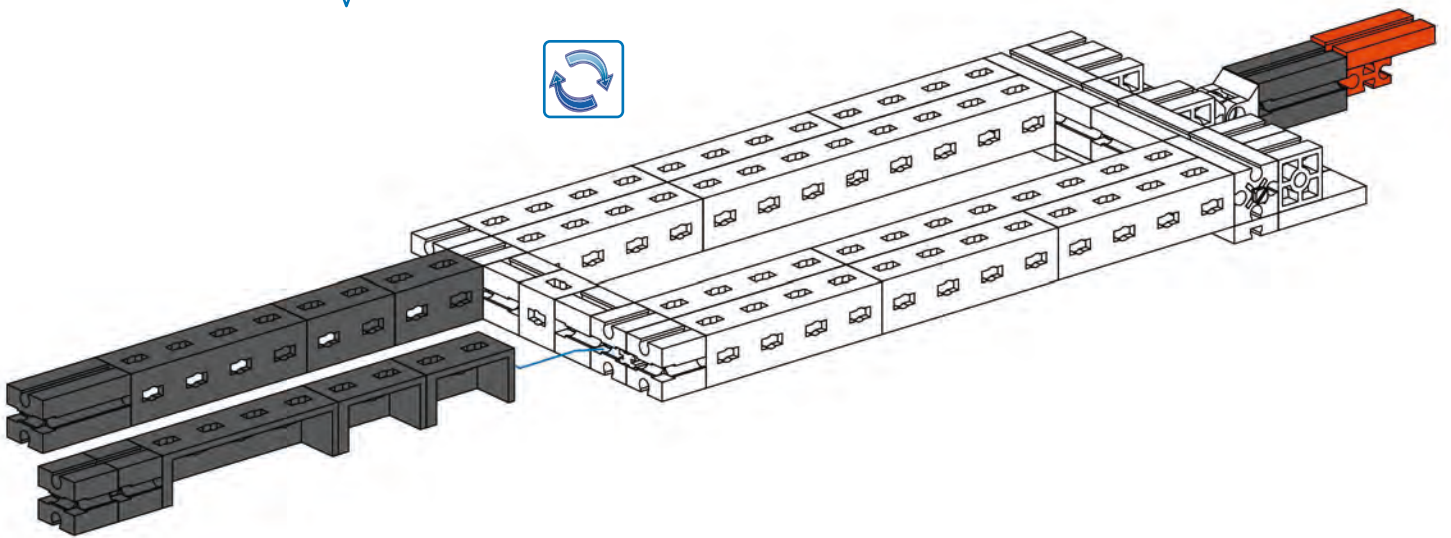

12

2x 2x 15 2x 2x

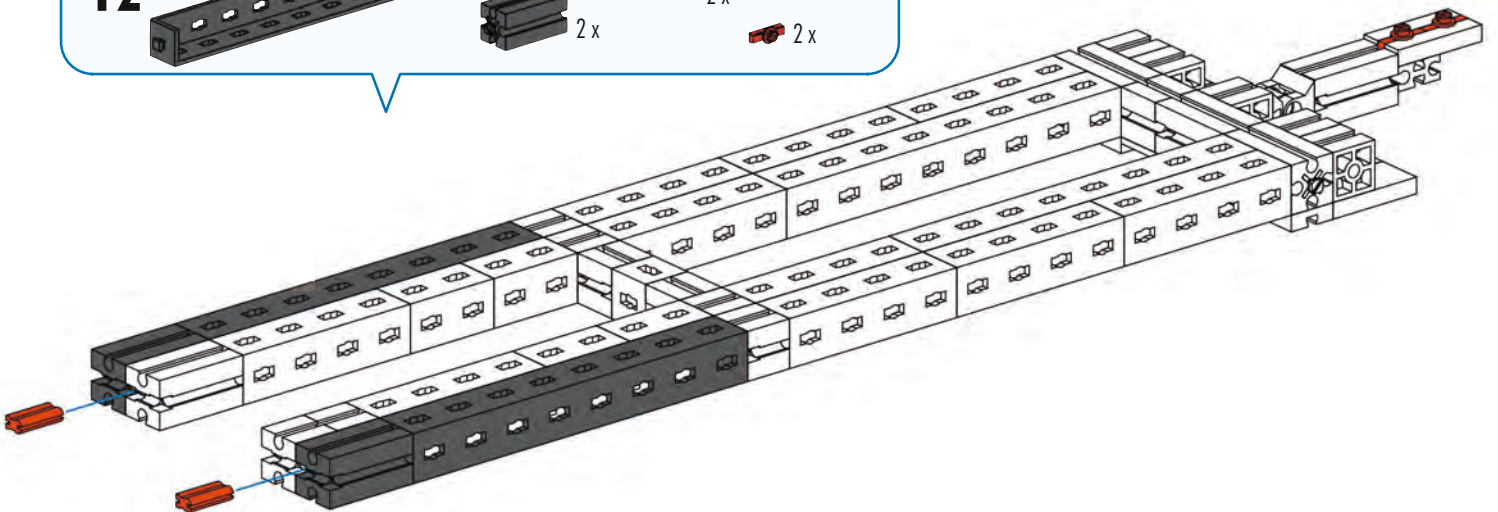

13

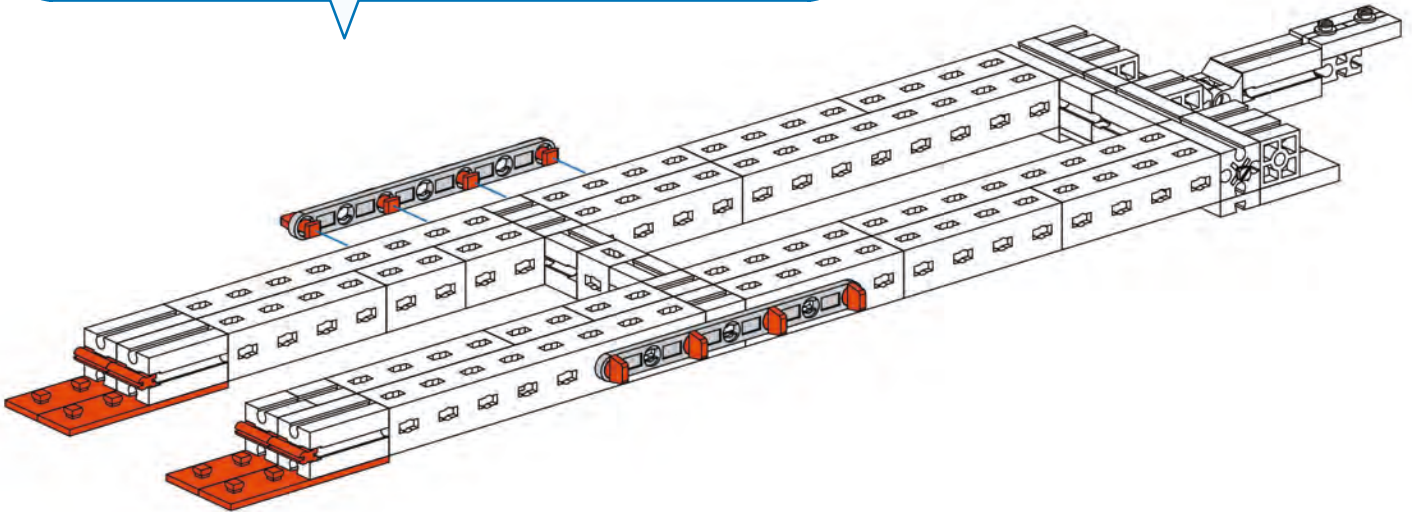

14

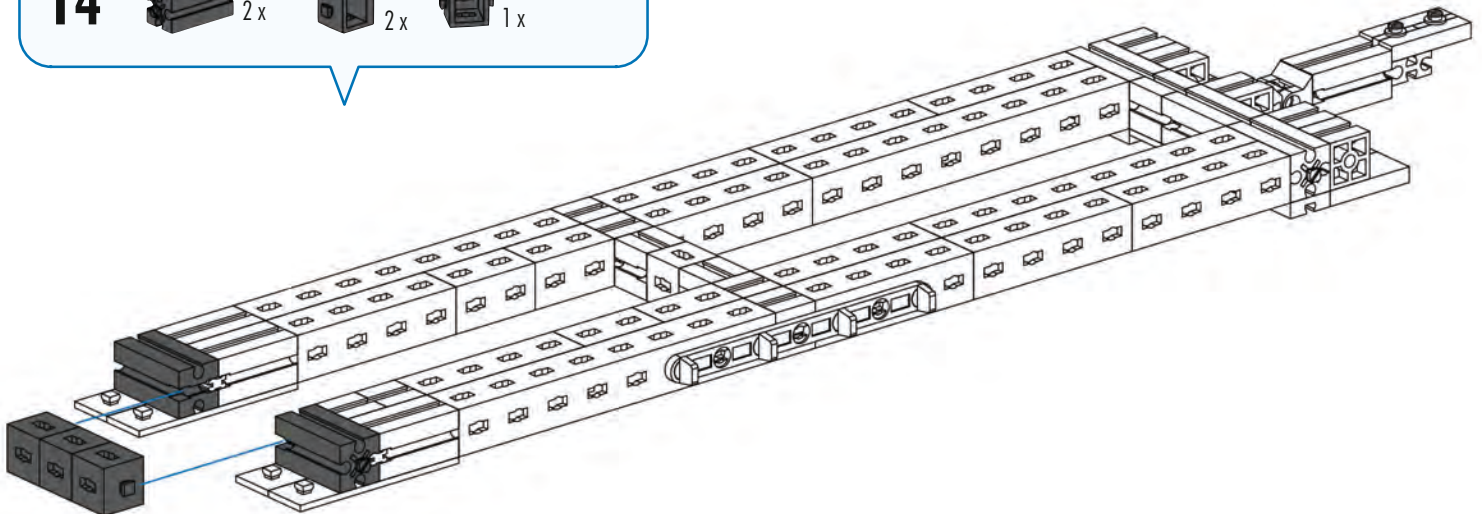

15

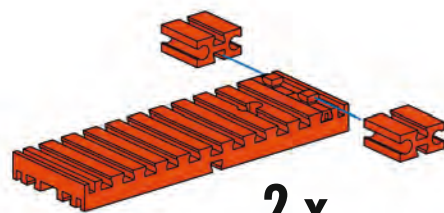
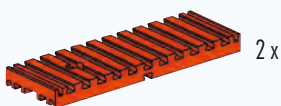

2 x

16

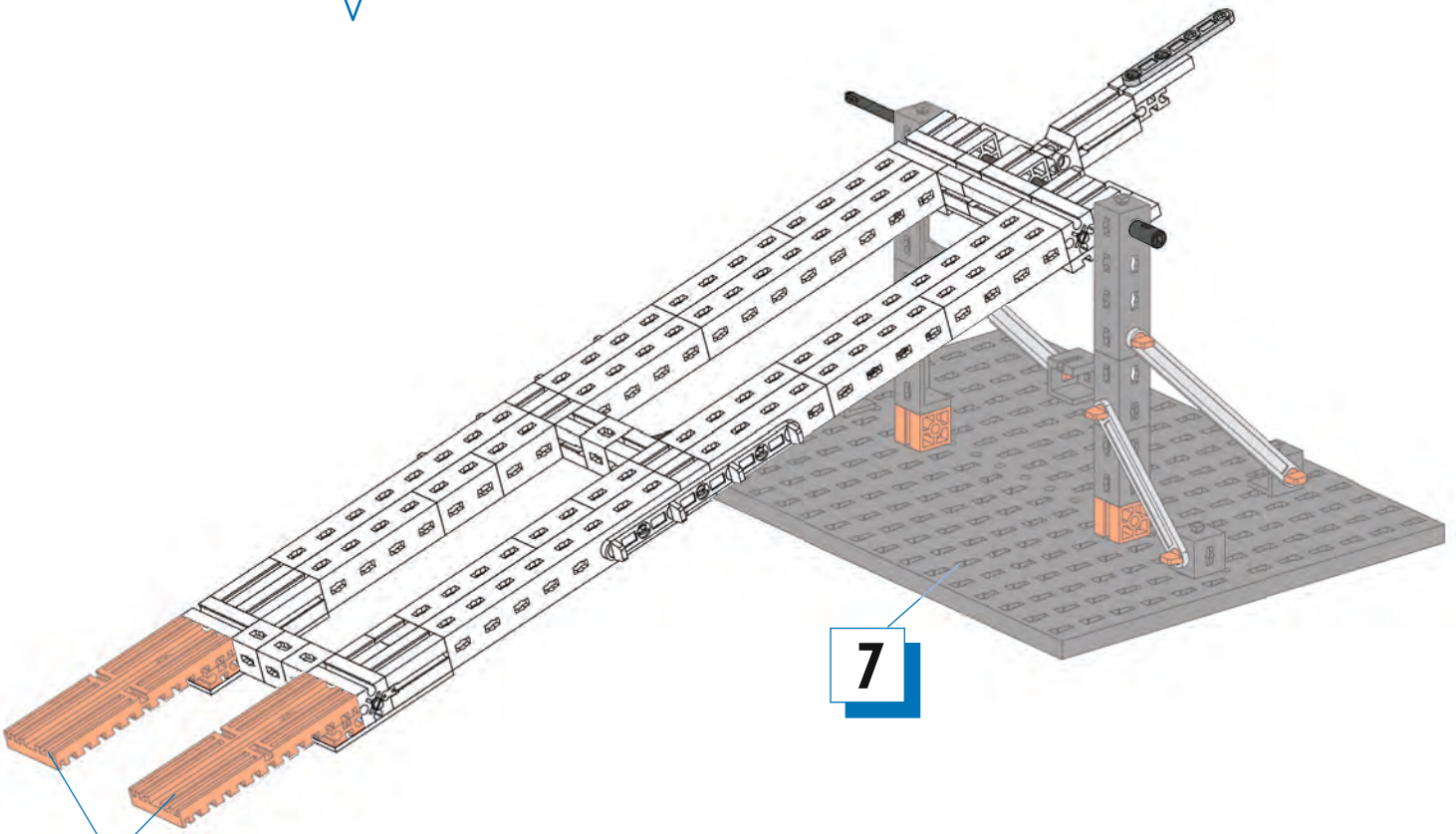

15

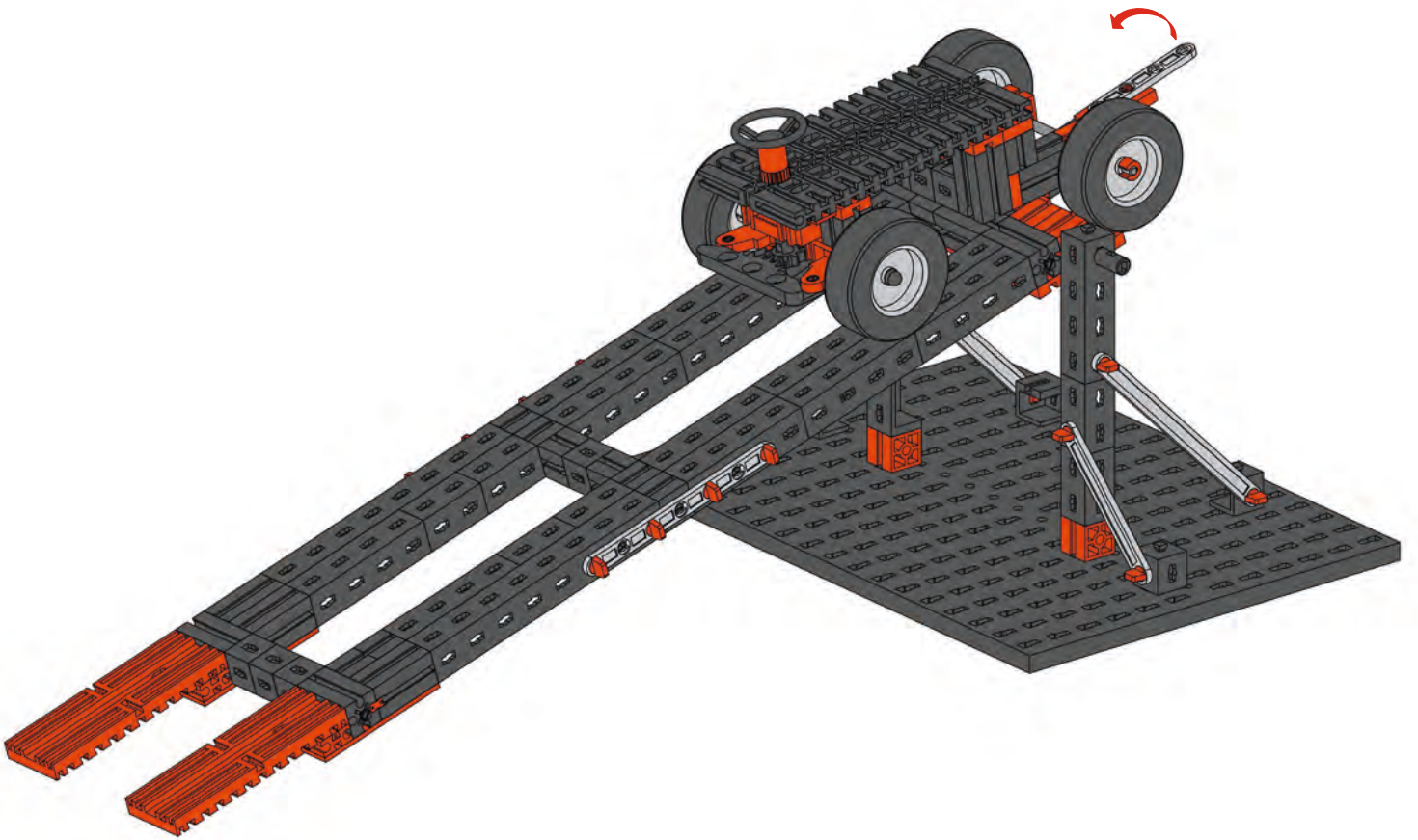



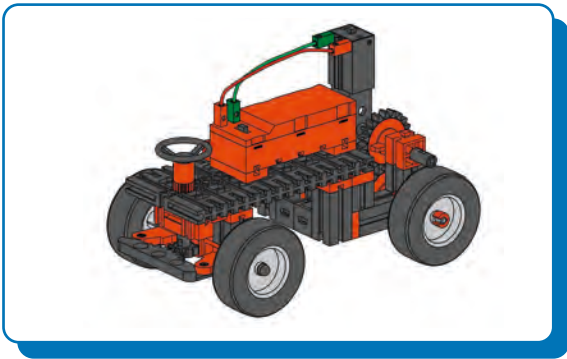

Fahrzeug 1  
Vehicle 1  
Véhicule 1

Voertuig 1  
Vehículo 1  
Veículo 1

Veicolo 1  
Автомобиль 1  
1号汽车

**5**

- 2 x (Orange 1x2 Technic Brick)
- 2 x (Orange Technic Pin 30)
- 1 x (Grey Technic Pin 110)
- 1 x (Red Technic Axle Pin)
- 1 x (Red Technic Axle Pin)
- 1 x (Black Technic Gear 24)
- 2 x (Black Technic Pin)

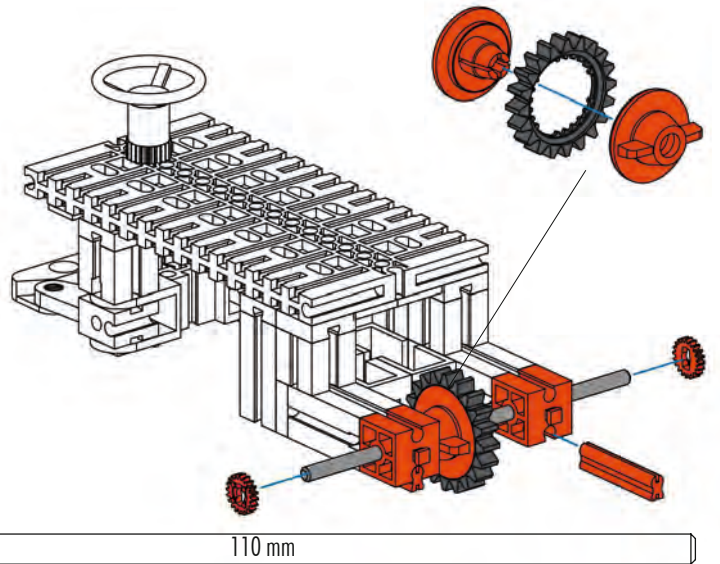

# 1-4

Seite 17  
Page 17  
Page 17  
Bladzijde 17  
Página 17  
Pagina 17  
Pagina 17  
Страница 17  
页次 17

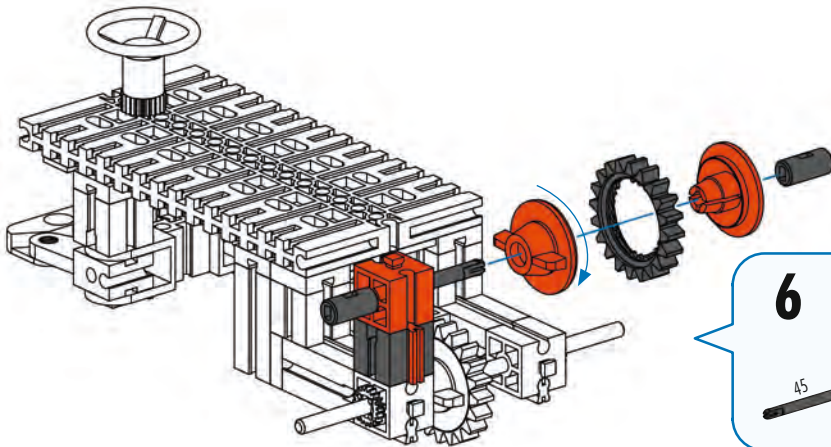

**6**

- 1 x (Black 1x2 Technic Brick)
- 1 x (Orange 1x2 Technic Brick)
- 1 x (Red Technic Axle Pin)
- 1 x (Black Technic Gear 24)
- 1 x (Grey Technic Pin 45)
- 2 x (Black Technic Pin)
- 1 x (Red Technic Pin 15)
- 1 x (Red Technic Axle Pin)

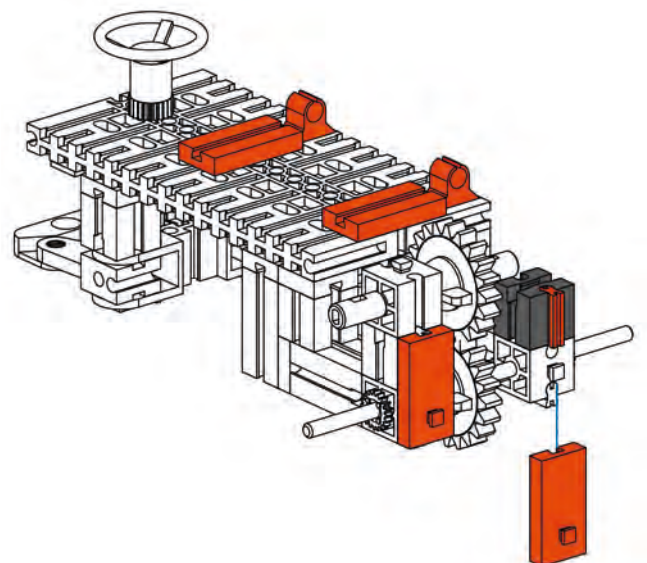
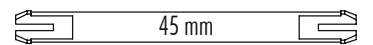

**7**

- 1 x (Black 1x2 Technic Brick)
- 1 x (Red Technic Pin 15)
- 2 x (Red Technic Axle Pin)
- 4 x (Orange 1x2 Technic Brick)

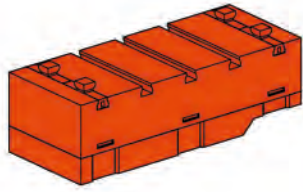

8

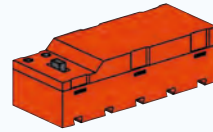

1 x

4 x

9



1 x



1 x



1 x

8

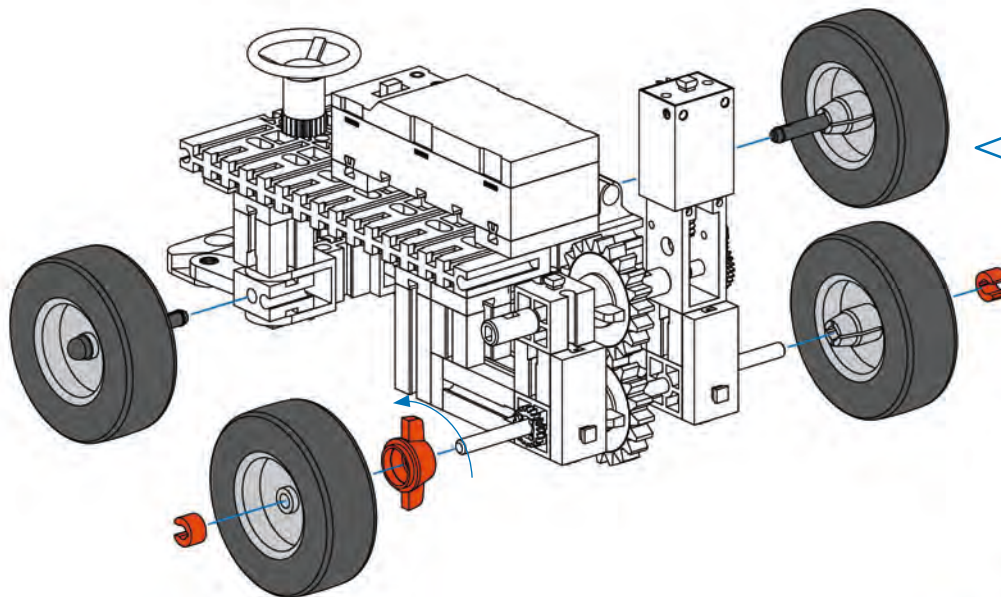
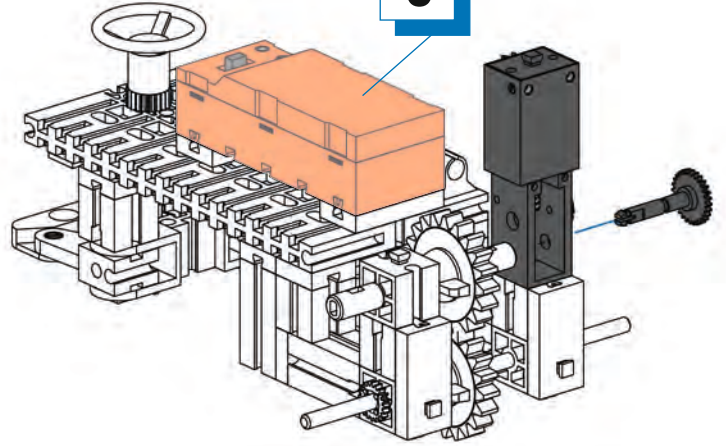

10

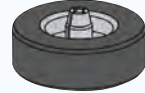

4 x

2 x



1 x



2 x

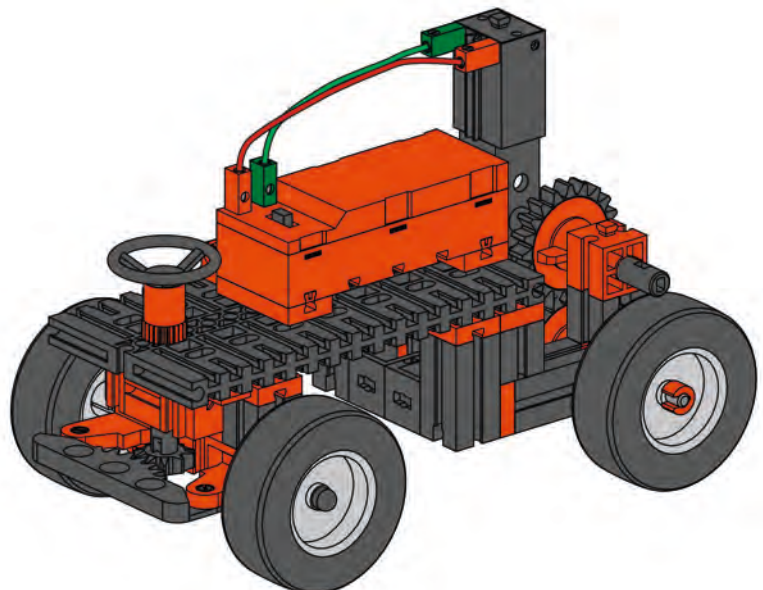



Fahrzeug 2  
Vehicle 2  
Véhicule 2

Voertuig 2  
Vehículo 2  
Veículo 2

Veicolo 2  
Автомобиль 2  
2号汽车

**5**

- 2 x 2x orange Technic brick
- 2 x 30 orange Technic axle
- 1 x 110 grey Technic axle
- 1 x orange Technic bush
- 1 x orange Technic bush
- 1 x black Technic gear
- 2 x black Technic axle pin

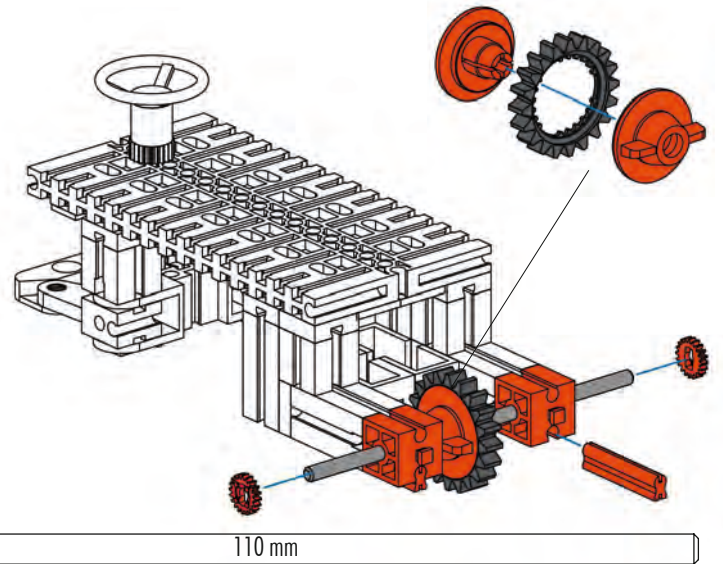

# 1-4

Seite 17  
Page 17  
Page 17  
Bladzijde 17  
Página 17  
Página 17  
Página 17  
Страница 17  
页次 17

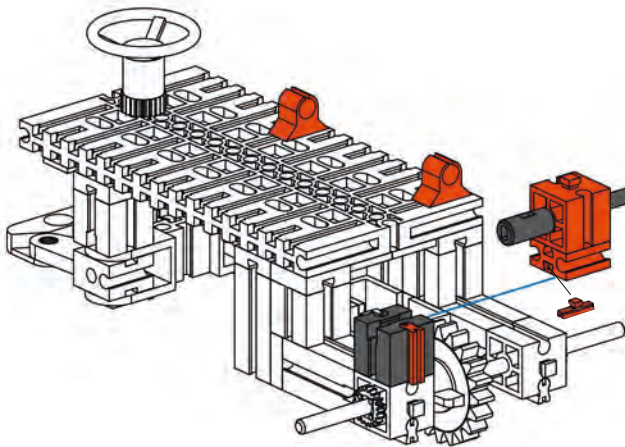

**6**

- 1 x black Technic axle
- 1 x 45 grey Technic axle
- 1 x 1x orange Technic brick
- 2 x black Technic axle pin
- 1 x 15 orange Technic axle
- 1 x orange Technic bush
- 2 x orange Technic bush
- 1 x orange Technic bush
- 1 x black Technic gear
- 1 x 1x orange Technic brick
- 1 x orange Technic bush

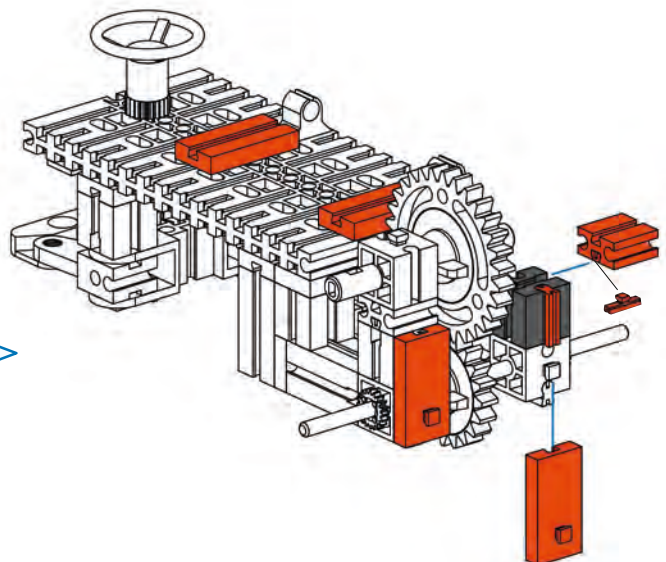
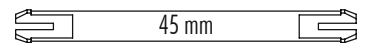

**7**

- 1 x black Technic axle
- 1 x 15 orange Technic axle
- 4 x orange Technic axle
- 1 x orange Technic bush
- 1 x orange Technic bush

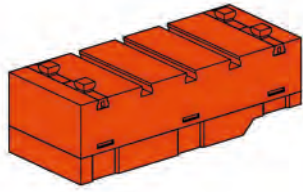

8

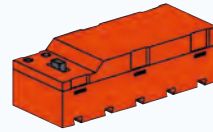

1 x

4 x

9



1 x



1 x



1 x

8

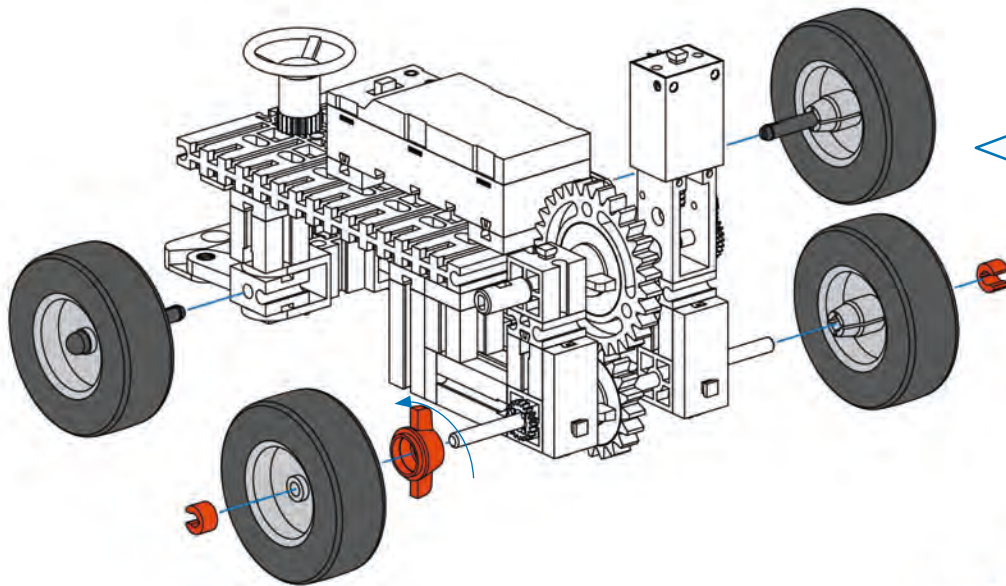
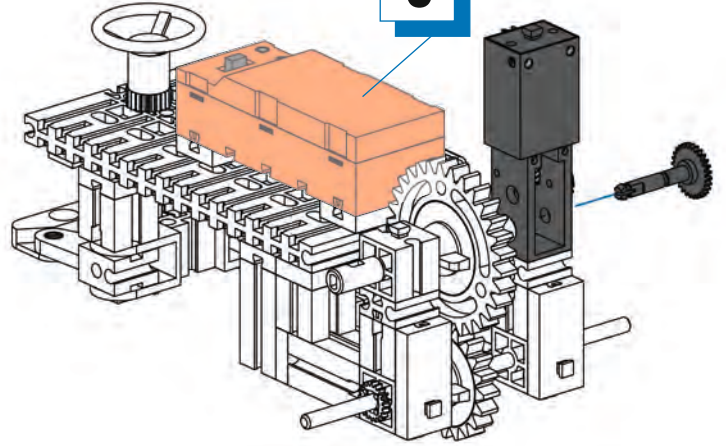

10



4 x

2 x



1 x



2 x

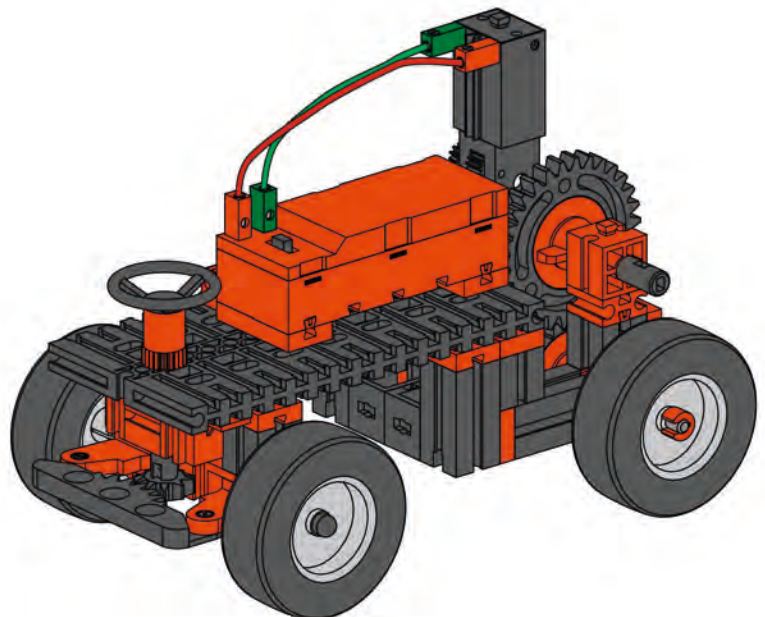

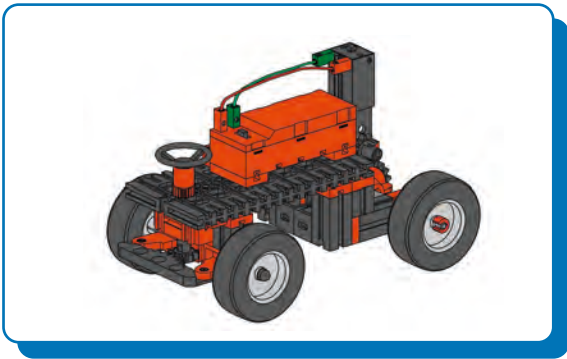

Fahrzeug 3  
Vehicle 3  
Véhicule 3

Voertuig 3  
Vehículo 3  
Veículo 3

Veicolo 3  
Автомобиль 3  
3号汽车

**5**

- 2 x
- 2 x
- 1 x
- 1 x
- 1 x
- 1 x
- 2 x

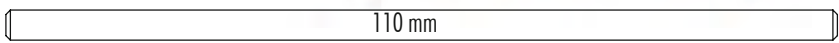
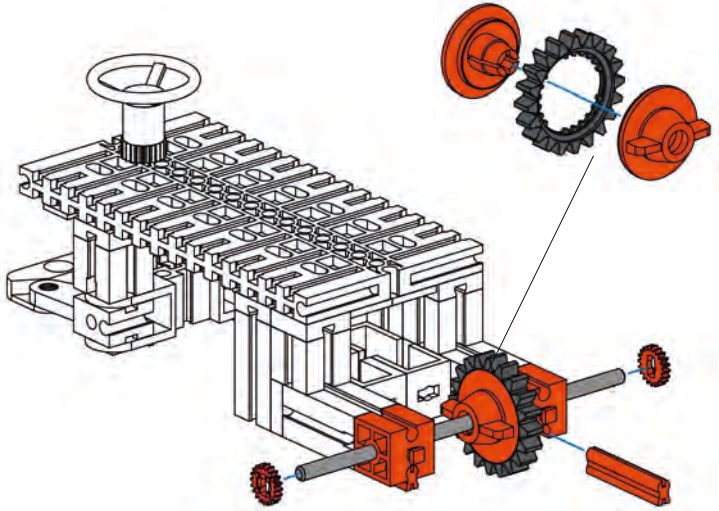

# 1-4

- Seite 17
- Page 17
- Page 17
- Bladzijde 17
- Página 17
- Página 17
- Página 17
- Страница 17
- 页次 17

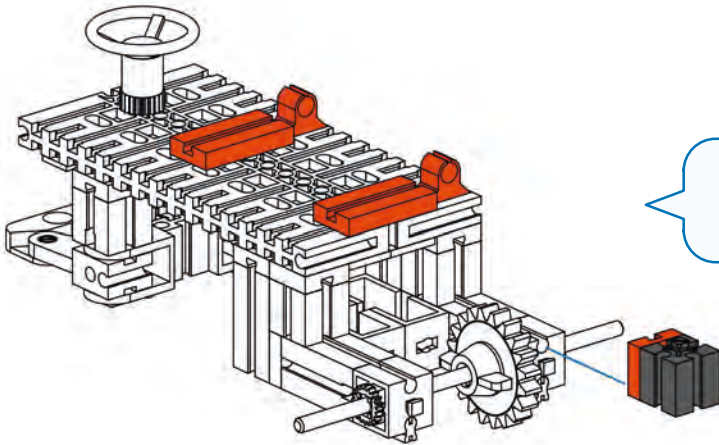

**6**

- 1 x
- 2 x
- 2 x
- 1 x

**7**

- 1 x
- 4 x

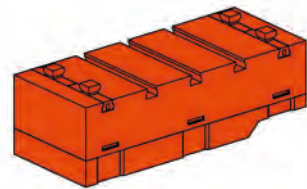

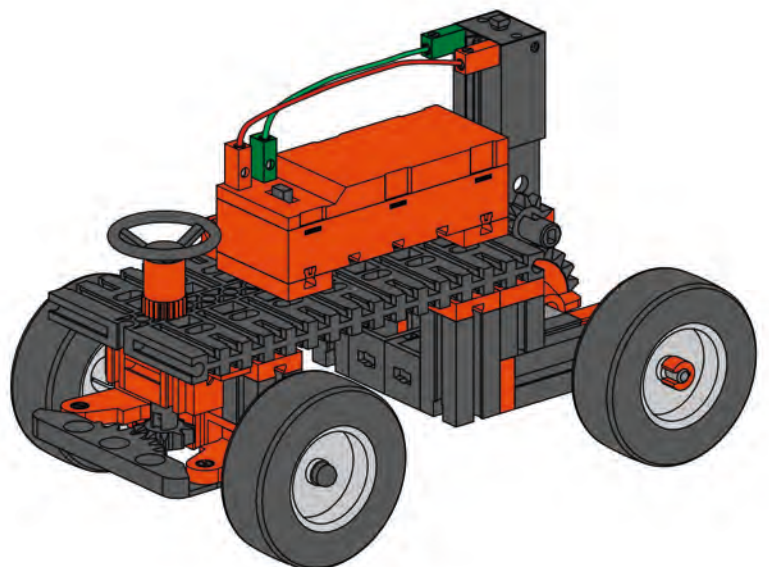
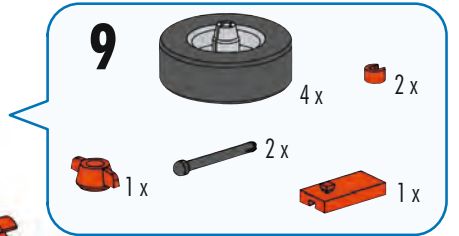
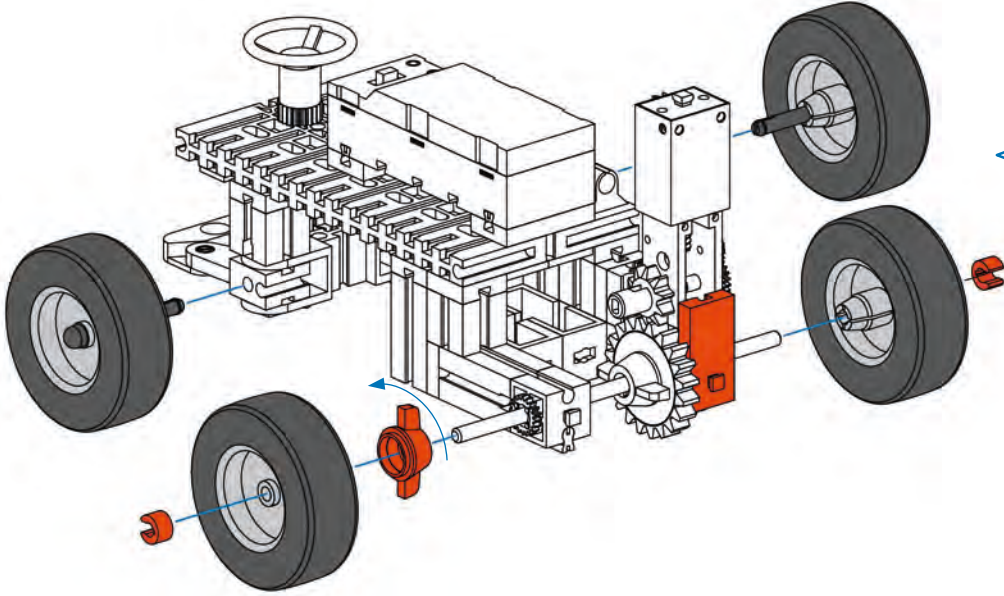
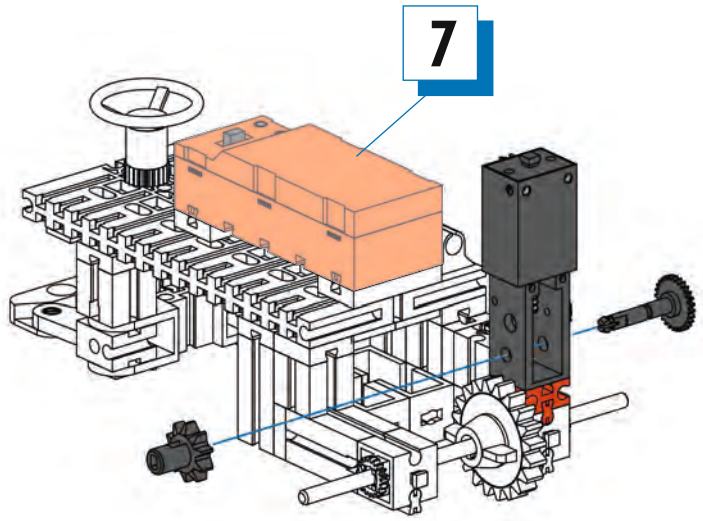
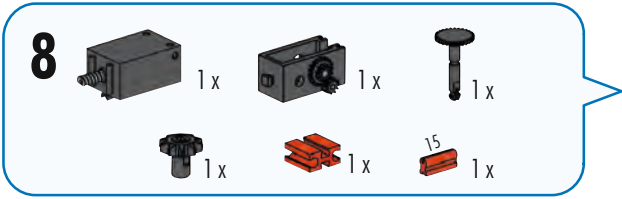

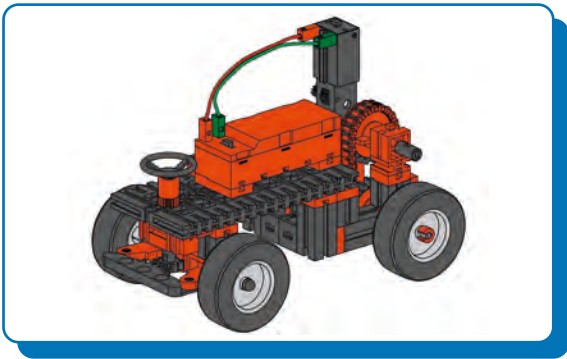

Fahrzeug 4  
Vehicle 4  
Véhicule 4

Voertuig 4  
Vehículo 4  
Veículo 4

Veicolo 4  
Автомобиль 4  
4号汽车

**5**

- 2 x (orange 1x2 Technic brick)
- 2 x (orange 30 Technic axle)
- 1 x (orange axle pin)
- 1 x (grey gear)
- 1 x (orange axle pin)
- 2 x (black axle pin)
- 1 x (grey axle, 110 mm)

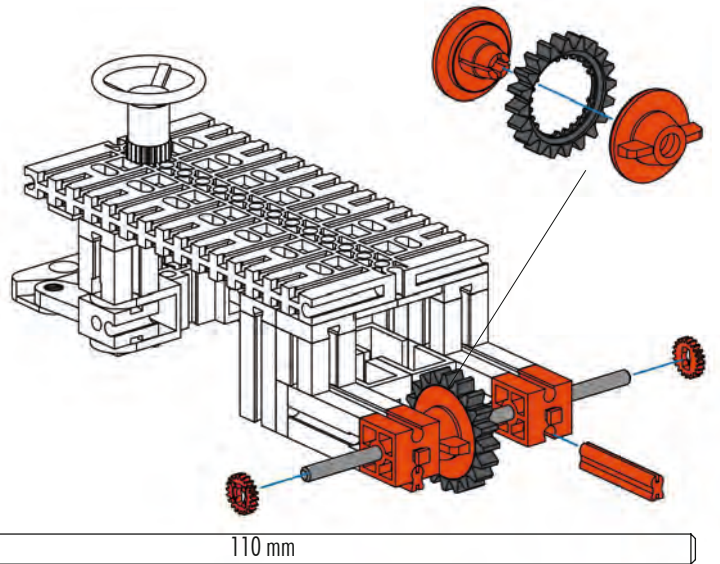

# 1-4

Seite 17  
Page 17  
Page 17  
Bladzijde 17  
Página 17  
Pagina 17  
Pagina 17  
Страница 17  
页次 17

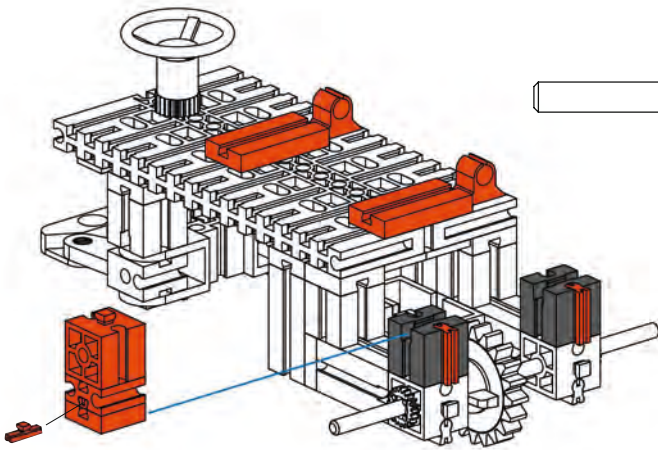

**6**

- 2 x (grey Technic axle)
- 1 x (orange 1x2 Technic brick)
- 2 x (orange 1x2 Technic brick)
- 2 x (orange Technic axle pin)
- 1 x (orange Technic axle pin)
- 1 x (orange Technic axle pin)
- 1 x (orange Technic axle pin)
- 2 x (orange 15 Technic axle)

**7**

- 1 x (orange 1x4 Technic brick)
- 4 x (orange Technic axle pin)

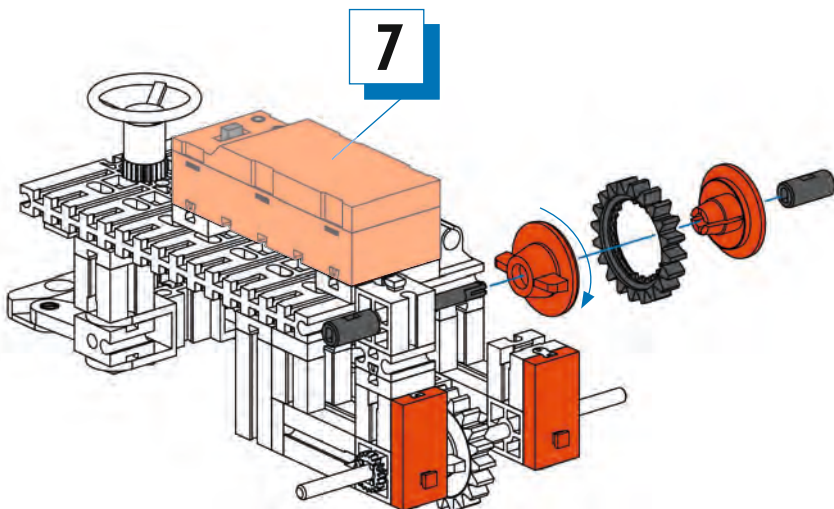
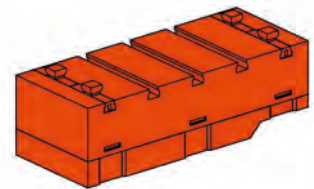

**8**

- 1 x (orange axle pin)
- 1 x (grey gear)
- 1 x (orange axle pin)
- 1 x (grey axle, 45 mm)
- 2 x (grey axle pin)
- 2 x (orange 1x2 Technic brick)

45 mm

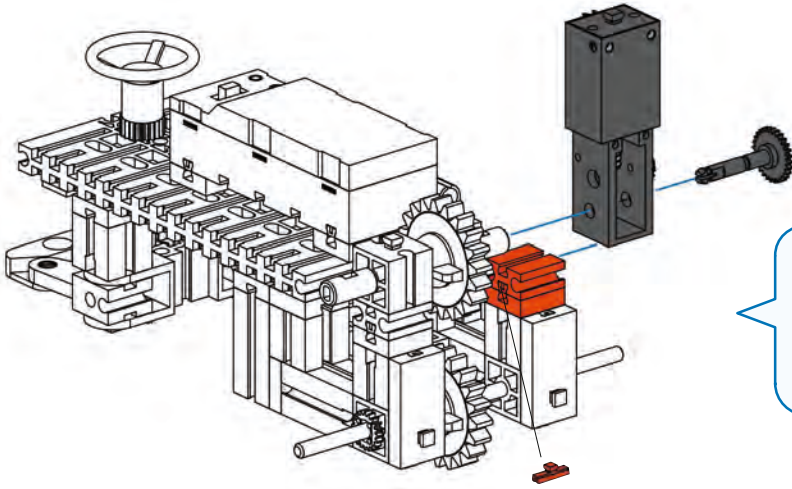

- 9**
- Motor 1x
  - Motor 1x
  - Pin 1x
  - Bracket 1x
  - Bracket 1x
  - Bracket 1x

- 10** Pin 38 x

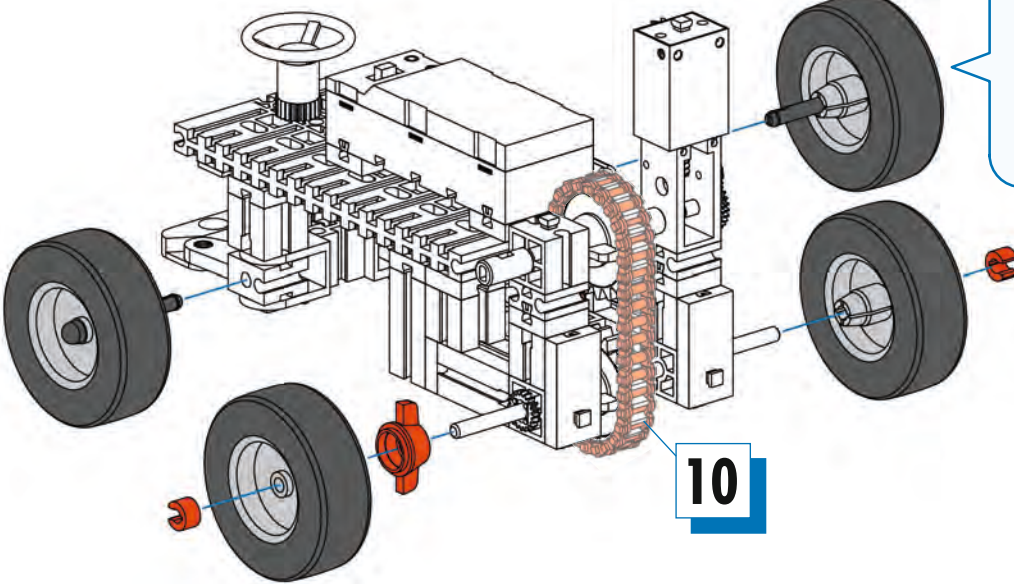

- 11**
- Wheel 4x
  - Connector 2x
  - Connector 1x
  - Pin 2x

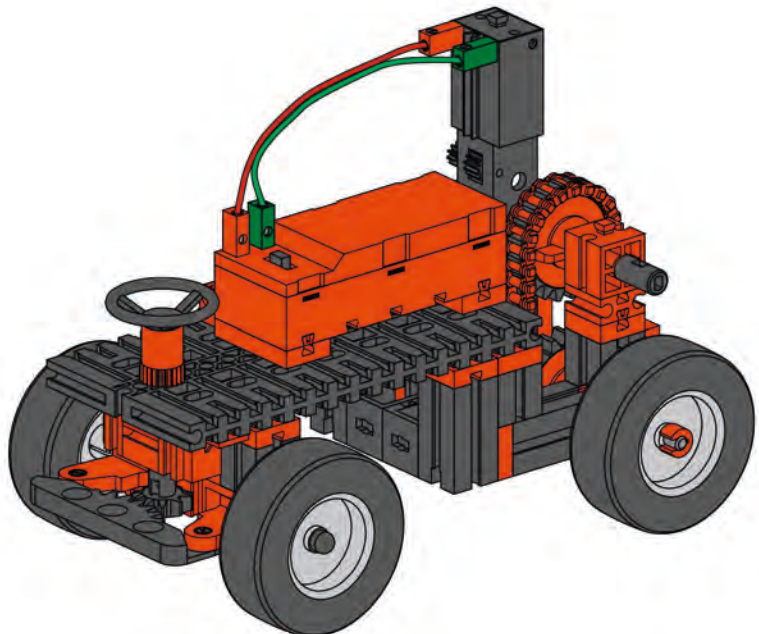





**Bollerwagen**  
**Handcart**  
**Chariot à main**

**Bolderkar**  
**Carro**  
**Carrinho de puxar**

**Carretto**  
**Тележка**  
**儿童手拉车**

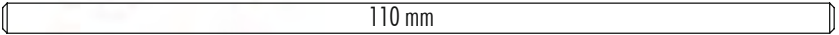
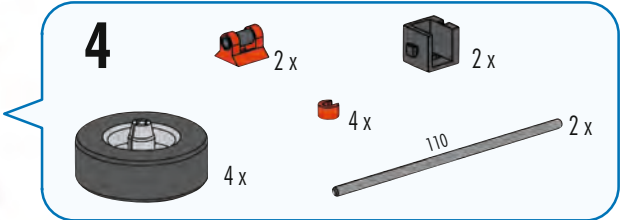
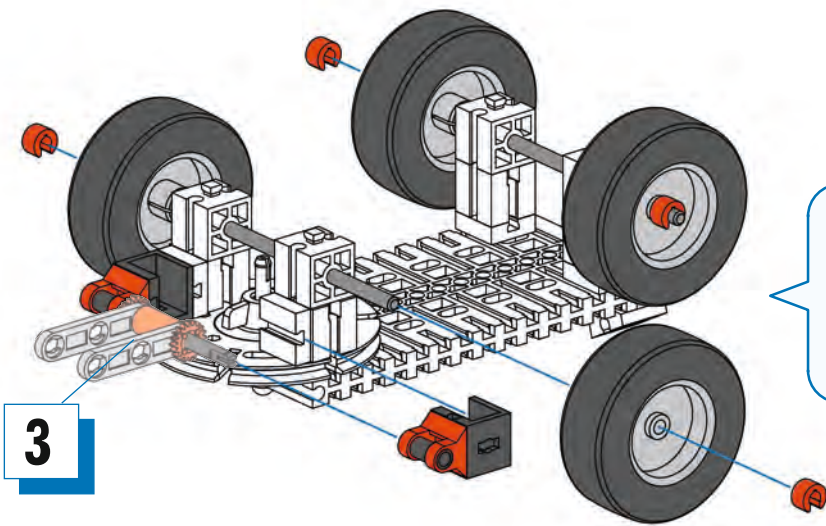
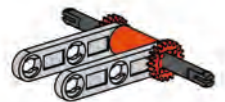
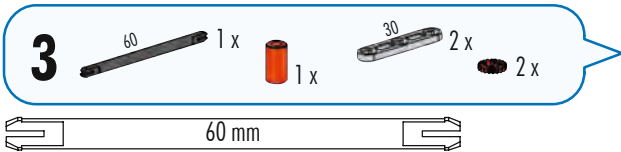
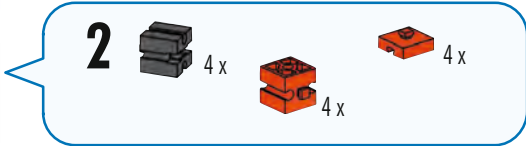
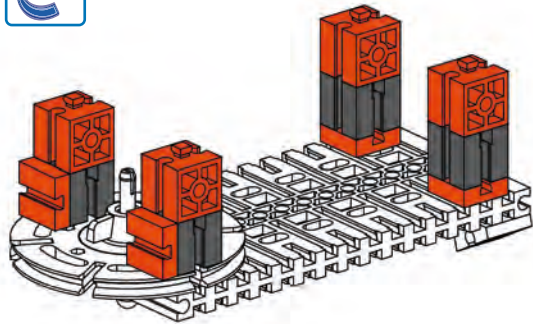
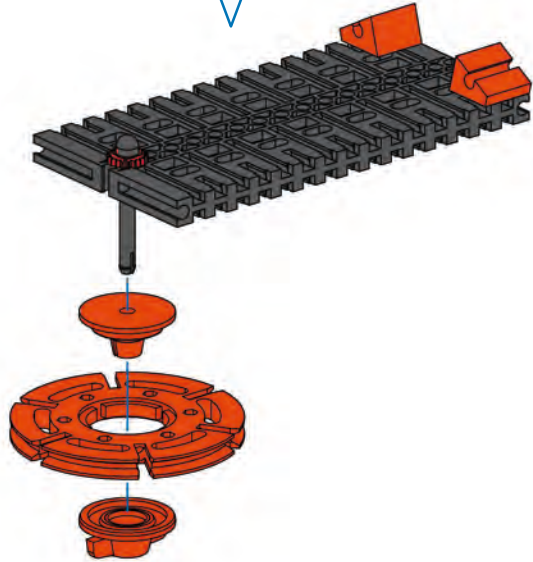
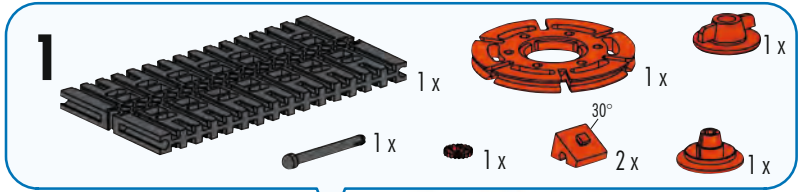

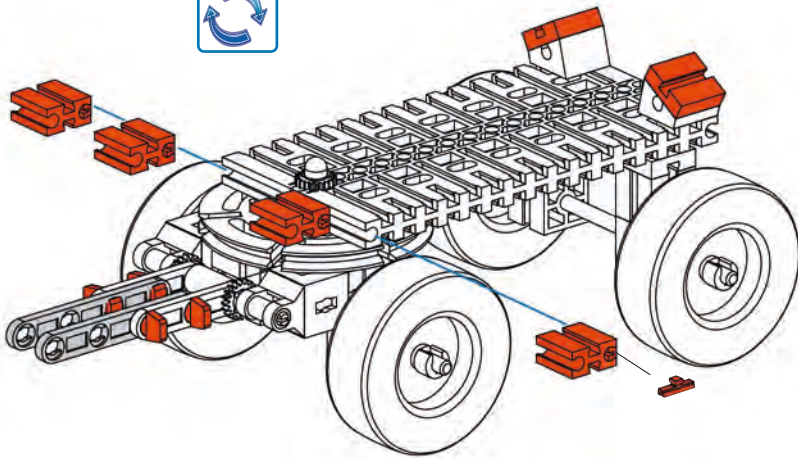

- 5**
- 4 x [Orange 1x3 Technic Brick]
  - 4 x [Orange 1x2 Technic Brick]
  - 2 x [Orange 1x1 Technic Brick]
  - 4 x [Red Pin with Friction Ridge]
  - 2 x [Grey Technic Beam 45]

- 6**
- 2 x [Grey Technic Beam 90]
  - 2 x [Grey Technic Beam 120]
  - 2 x [Grey Technic Beam 75]
  - 2 x [Orange 1x3 Technic Brick]
  - 4 x [Grey Technic Connector]
  - 1 x [Grey Technic Beam 60]
  - 2 x [Orange 30° Technic Brick]
  - 2 x [Orange 1x2 Technic Brick]
  - 3 x [Red Pin with Friction Ridge]
  - 2 x [Grey Technic Pin]
  - 12 x [Red Pin with Friction Ridge]

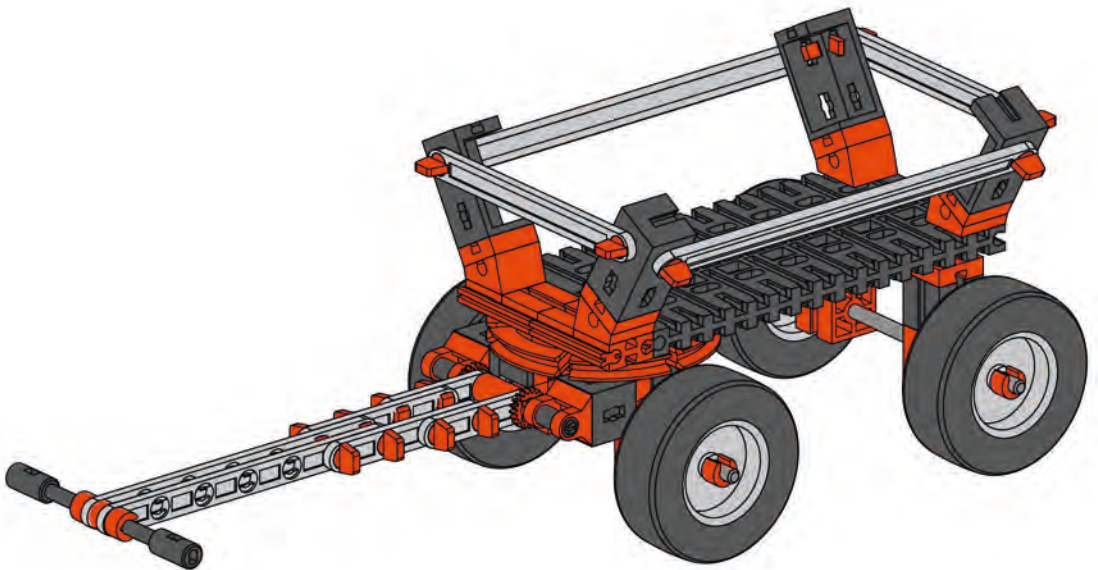
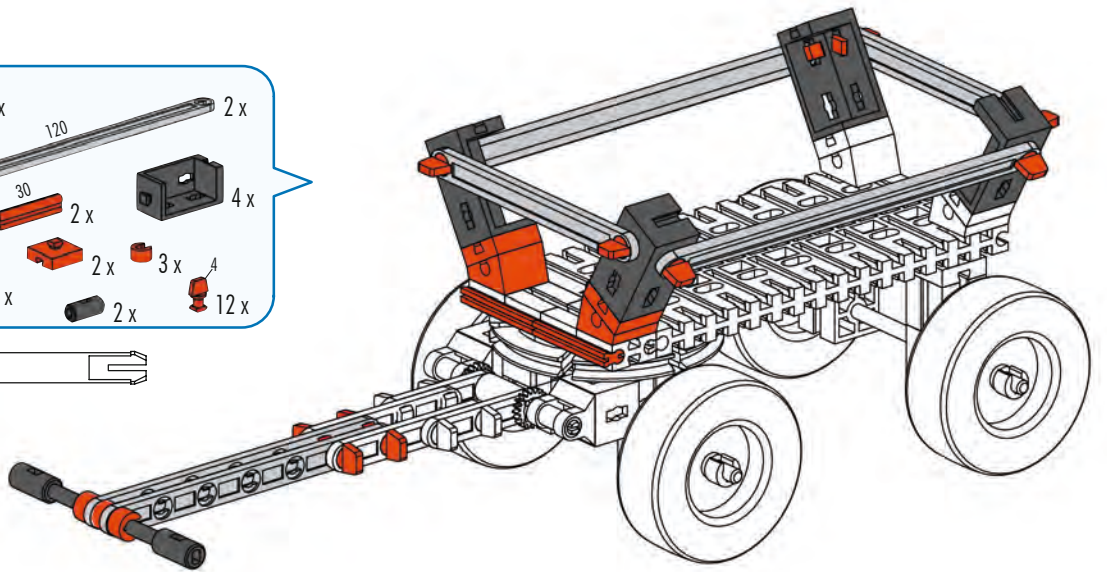
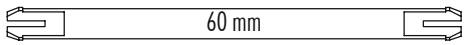

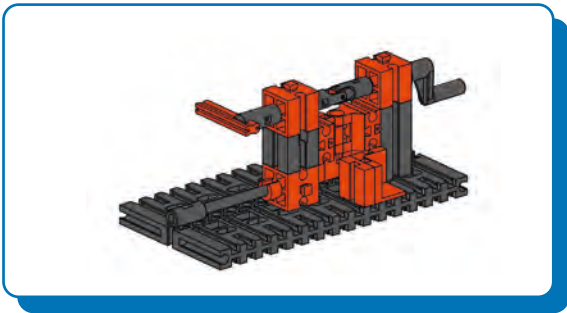

**Kardangelenk**  
**Cardan joint**  
**Joint de cardan**

**Cardanoverbrenging**  
**Articulación cardán**  
**Junta universal**

**Giunto cardanico**  
**Карданный шарнир**  
**万向节**

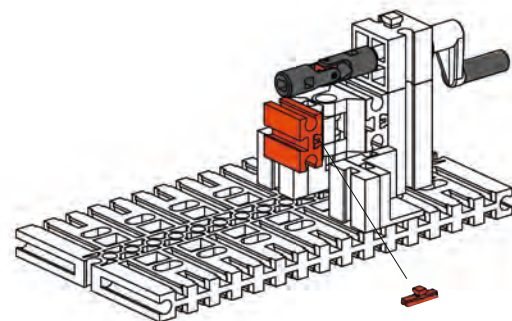
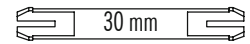
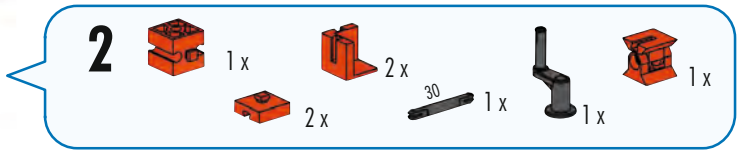
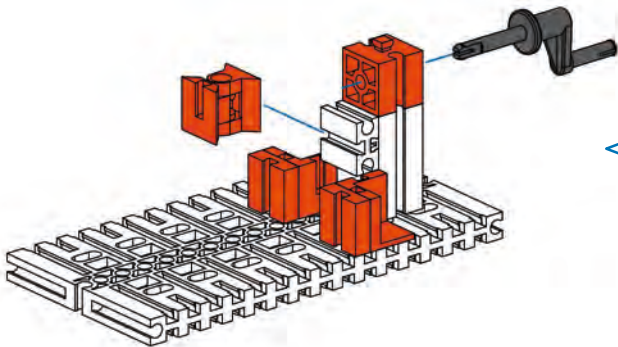
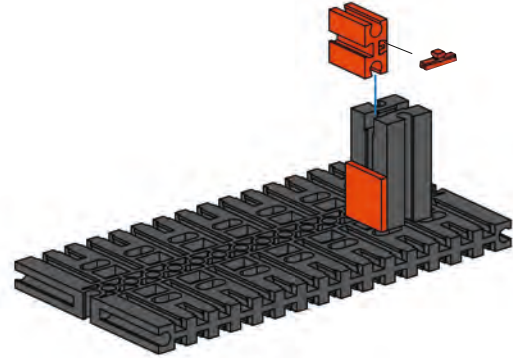
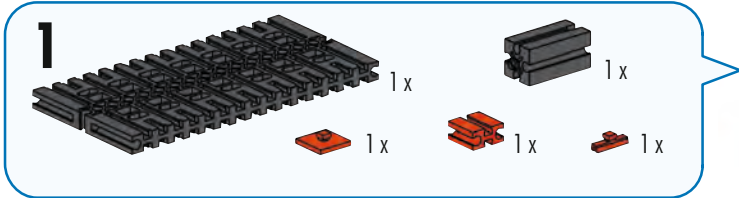

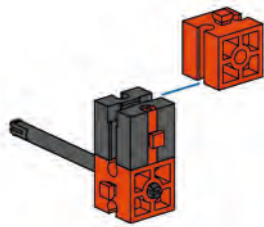

**4** 2x 1x 1x 45 1x

45 mm

**5** 30 1x 1x 30 1x 1x 1x

30 mm

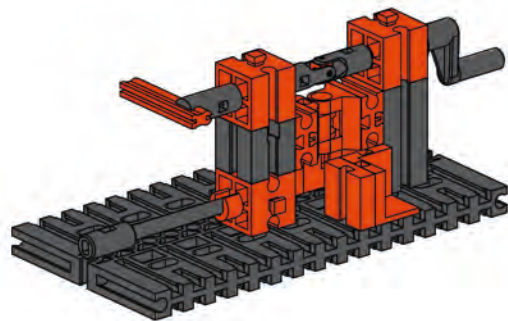
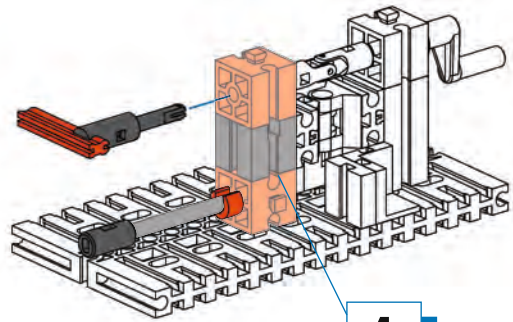

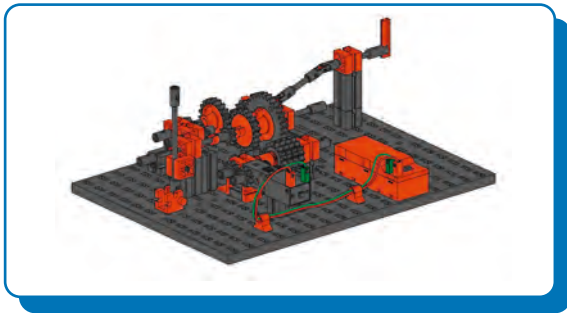

Schaltgetriebe  
Gearbox  
Mécanisme intermittent

Schakeloverbrenging  
Cambio de velocidades  
Caixa de câmbio

Cambio meccanico  
Коробка передач  
变速器

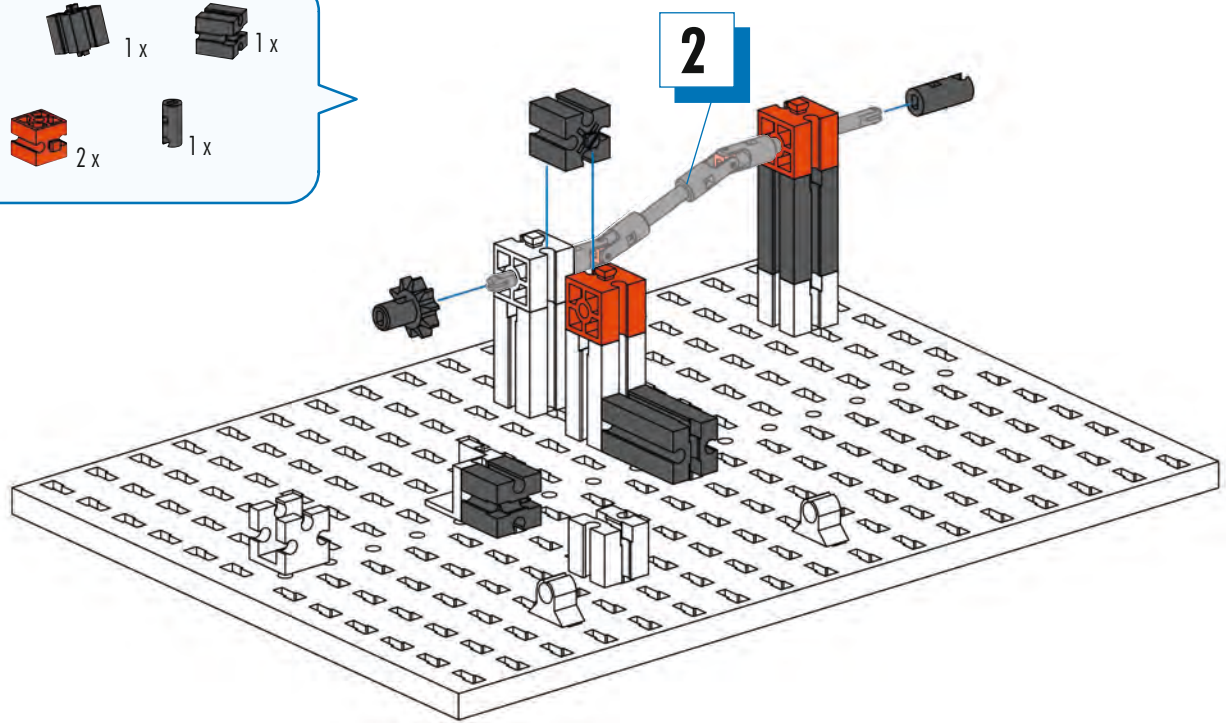
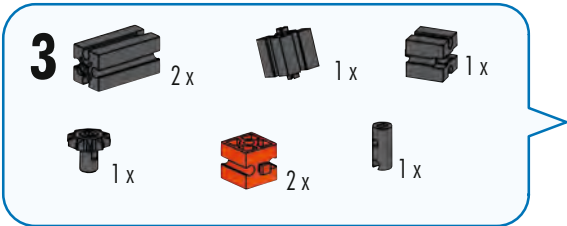
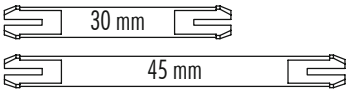
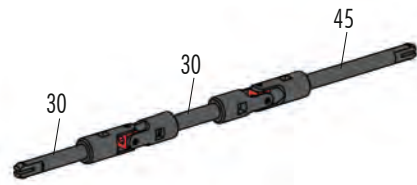
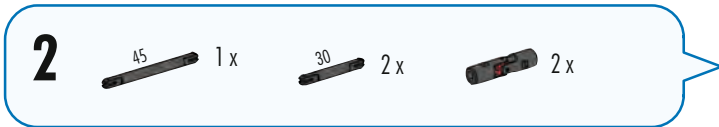
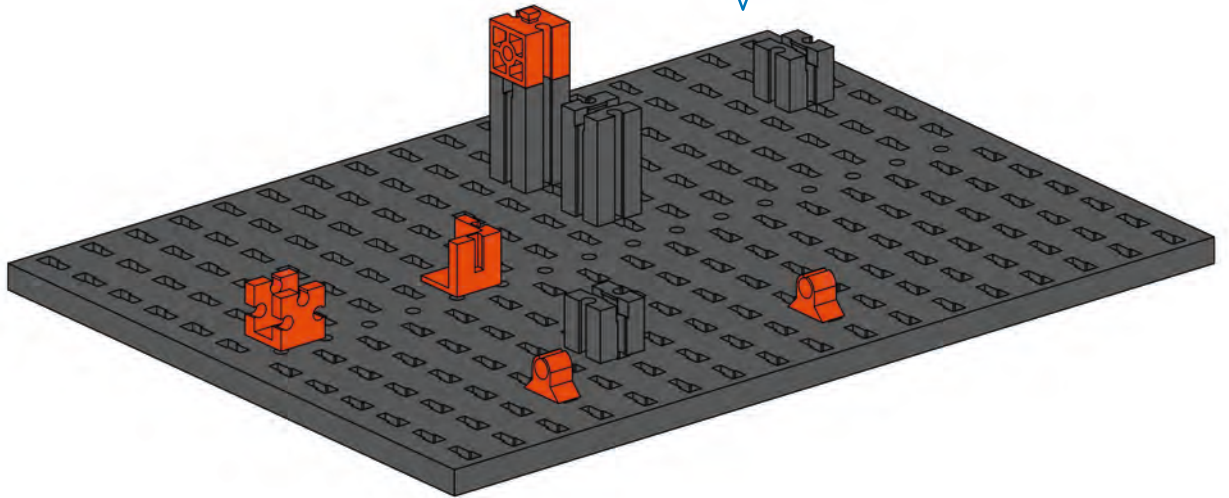
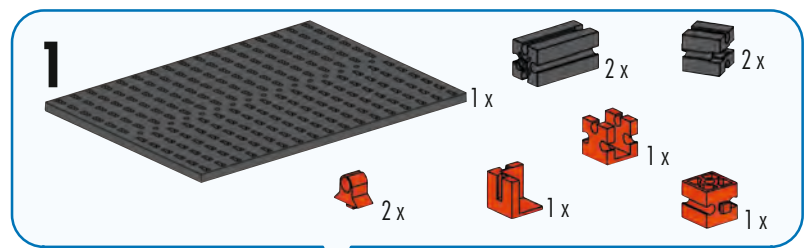

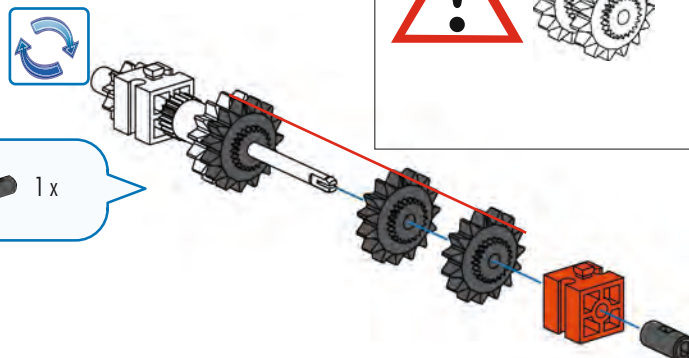
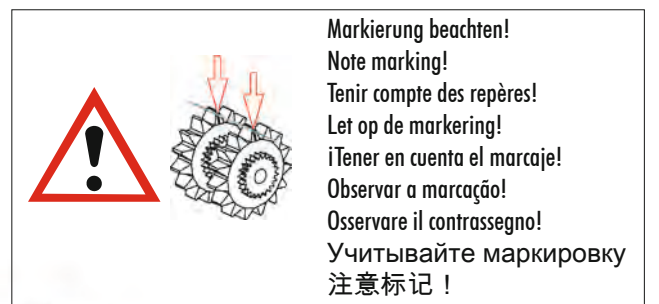
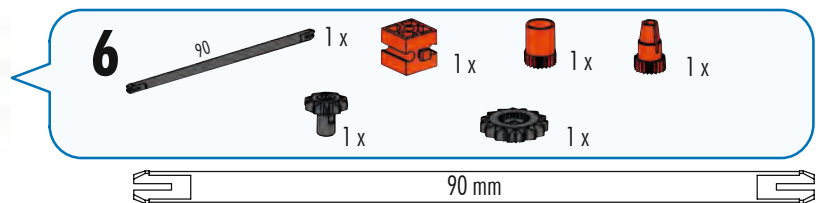
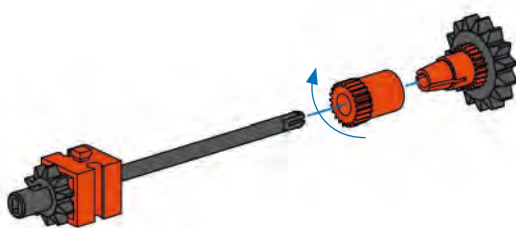
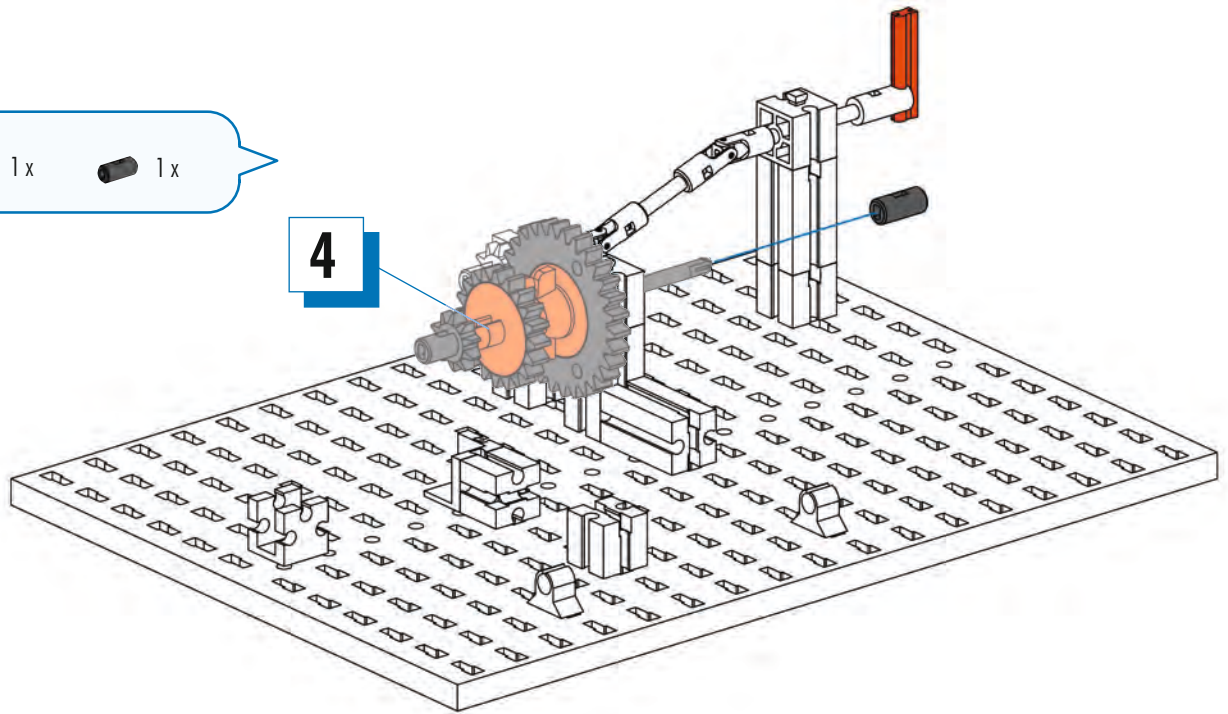
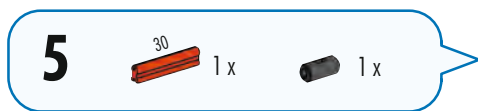
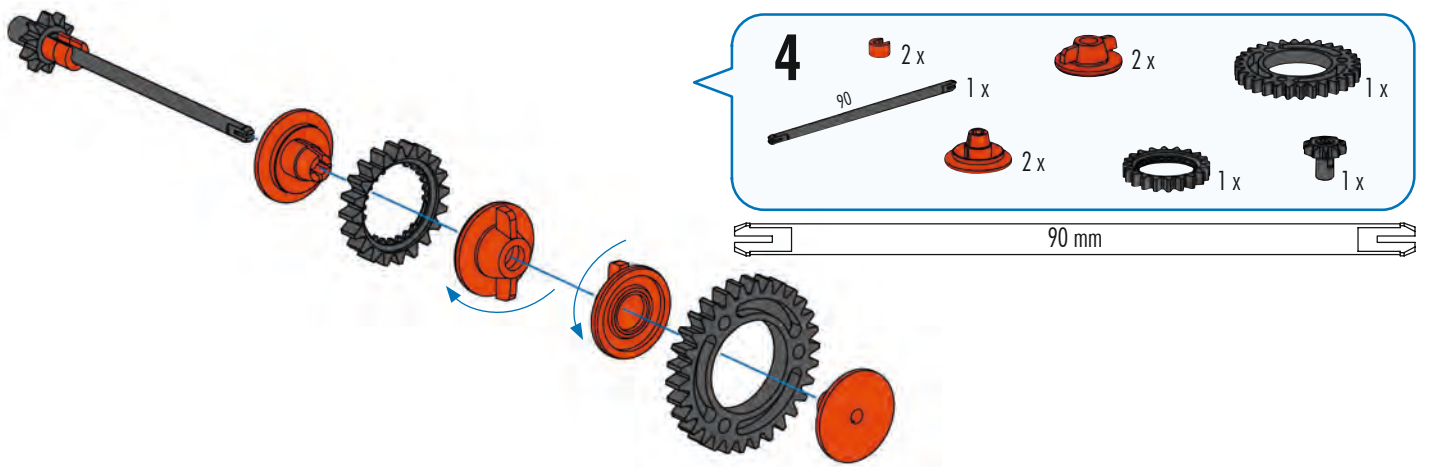

8

2 x 15 1 x 1 x

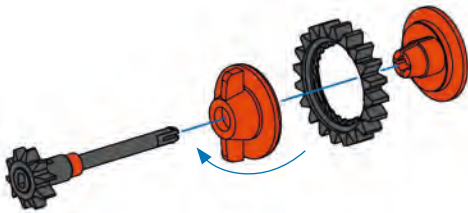
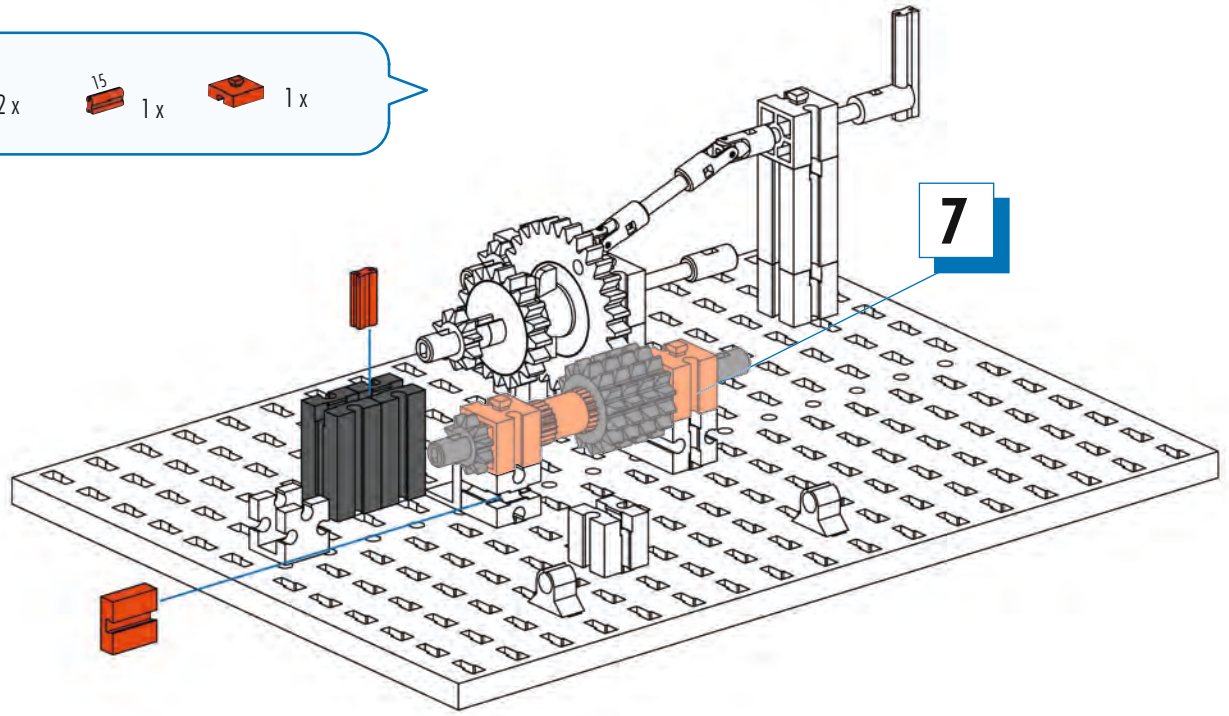

9

45 1 x 1 x 1 x 1 x 1 x 1 x

45 mm

10

1 x 1 x 1 x

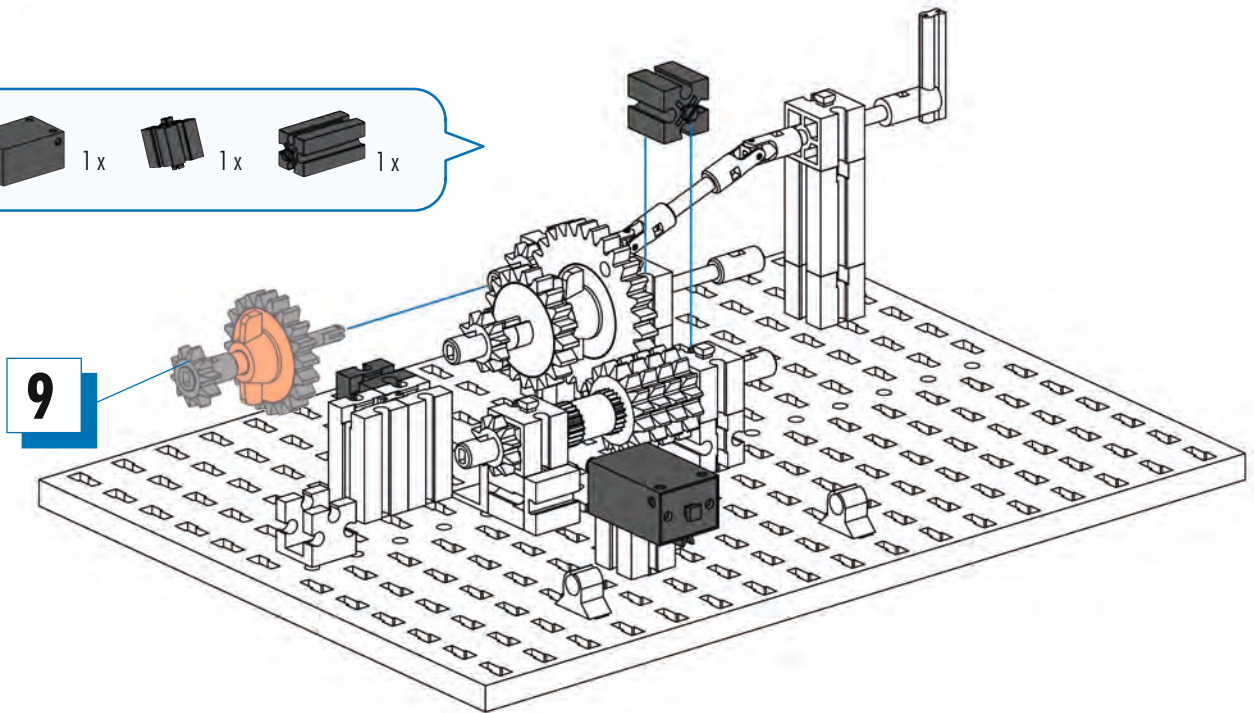

11

1 x 4 x

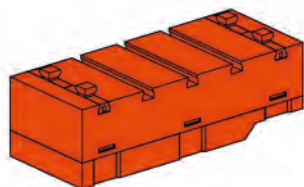

12

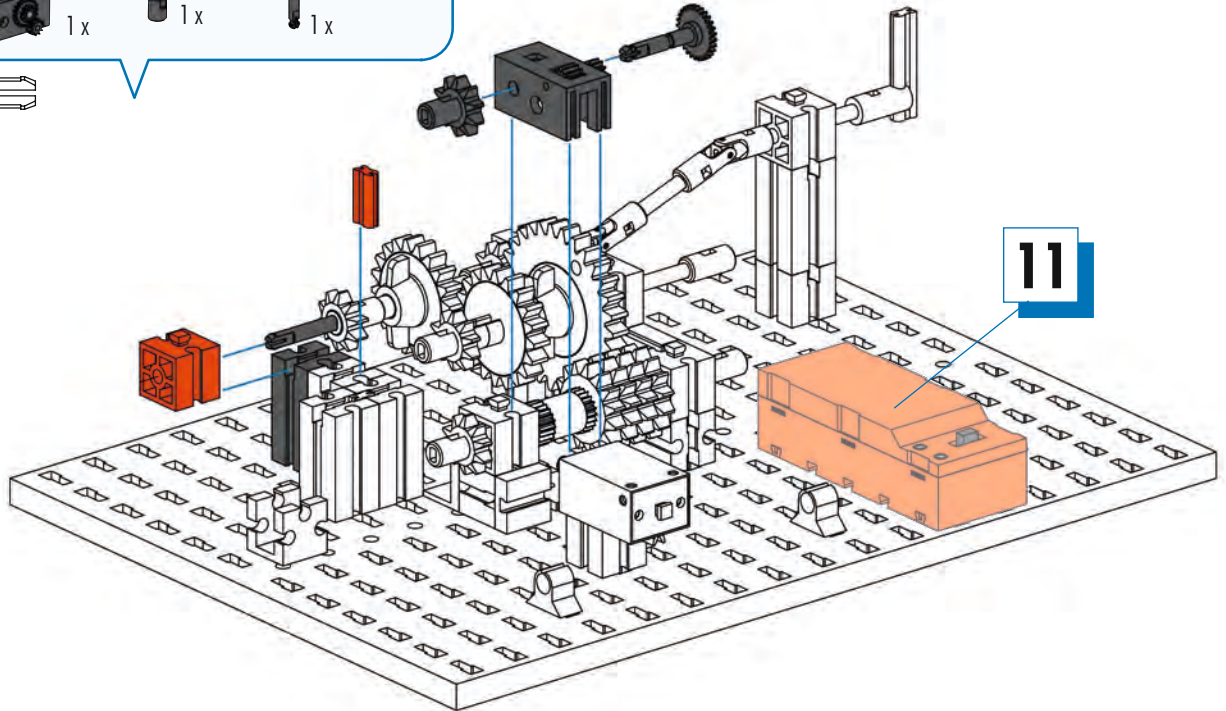
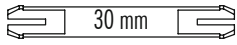
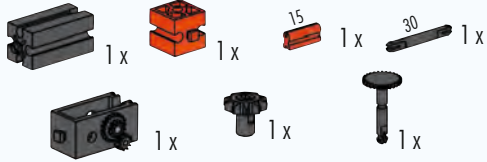

11

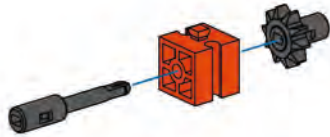

13

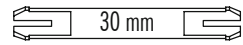

14

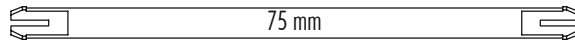
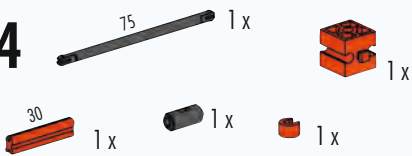

13

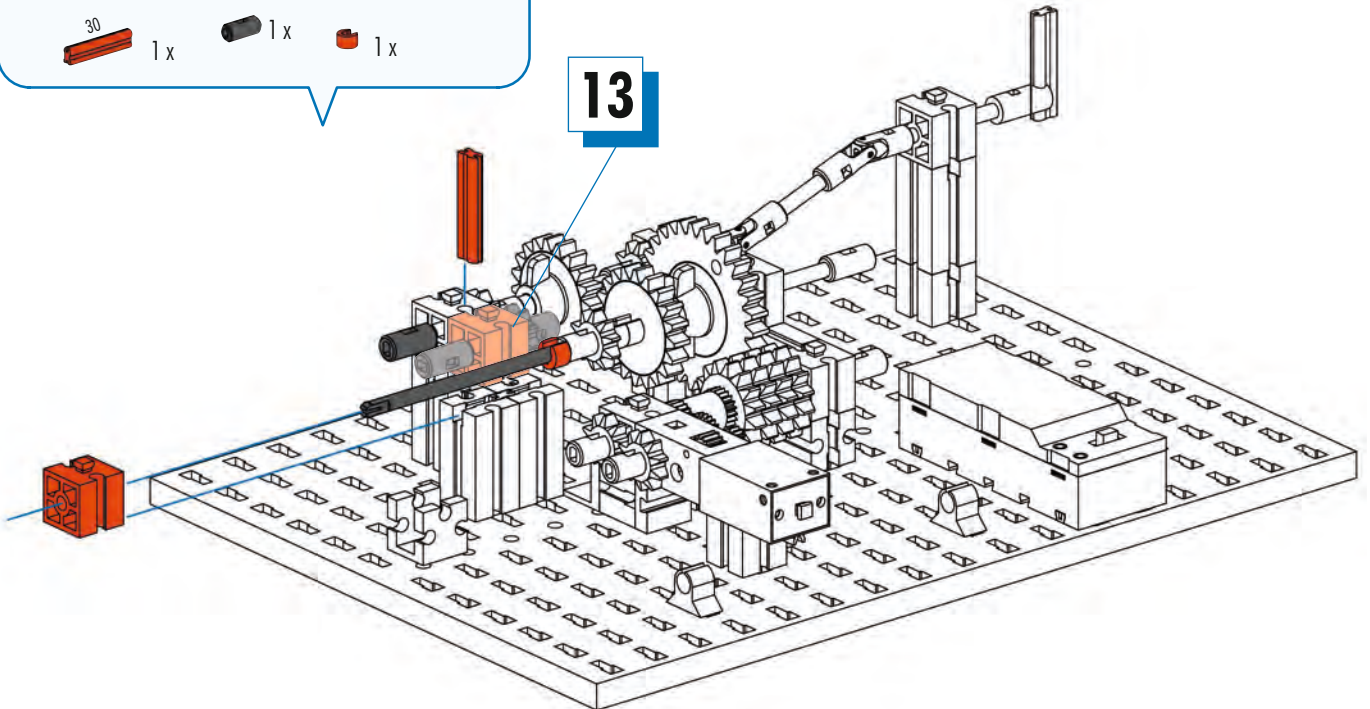



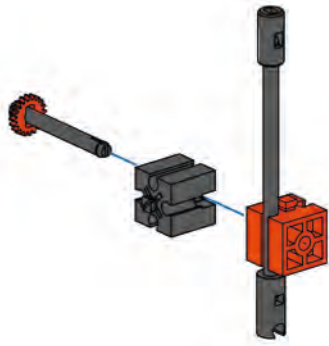

- 15**
- 1x
  - 1x
  - 1x
  - 1x
  - 1x
  - 1x
  - 1x
  - 1x

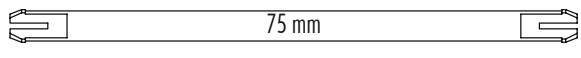

- 16**
- 1x
  - 1x
  - 1x

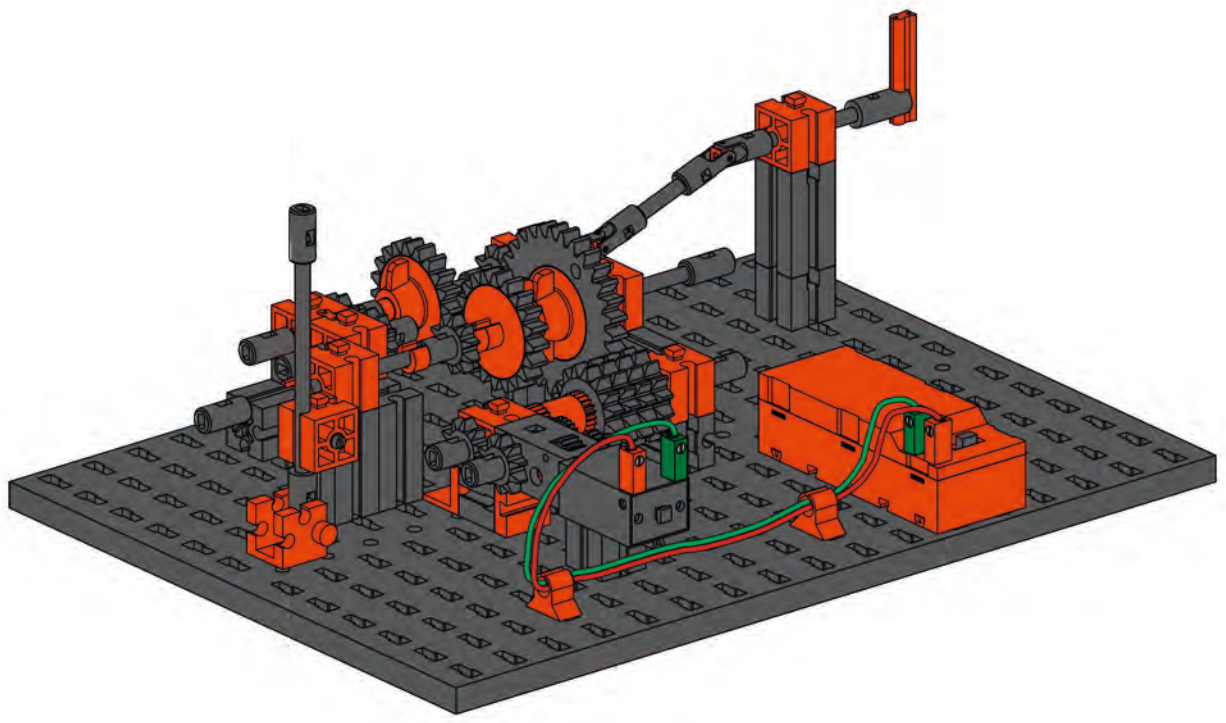
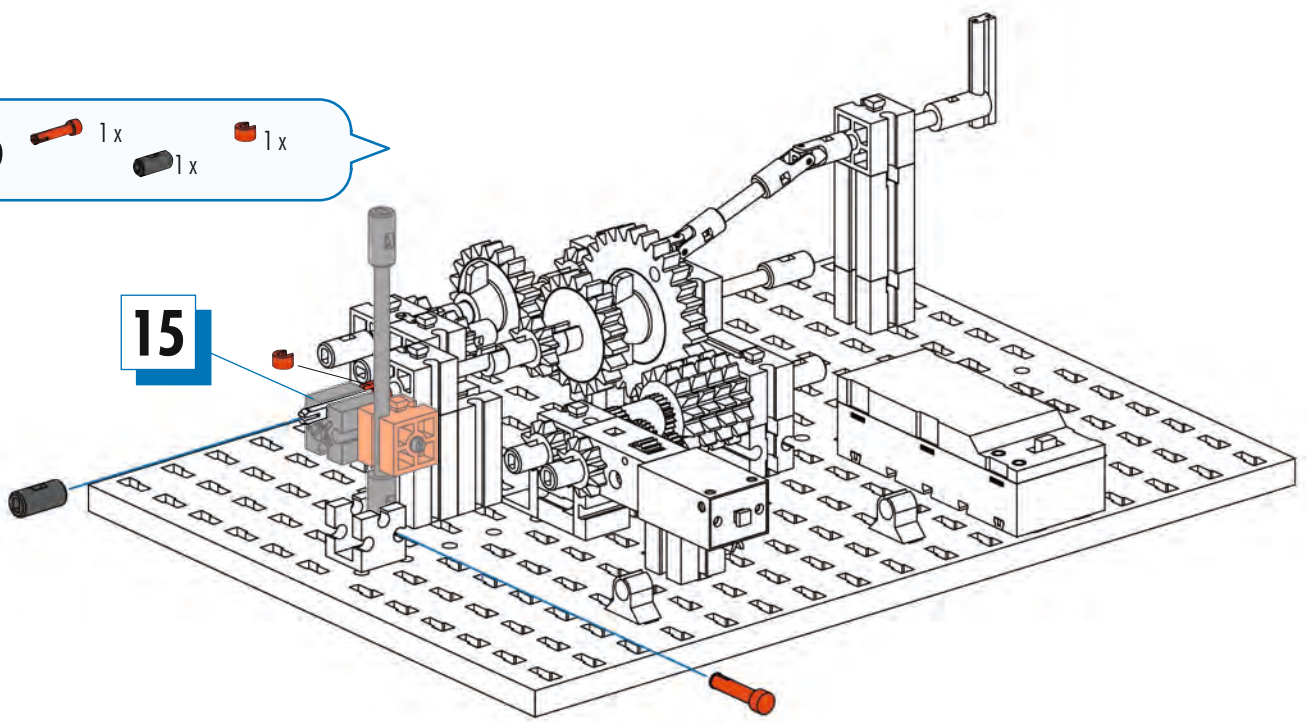

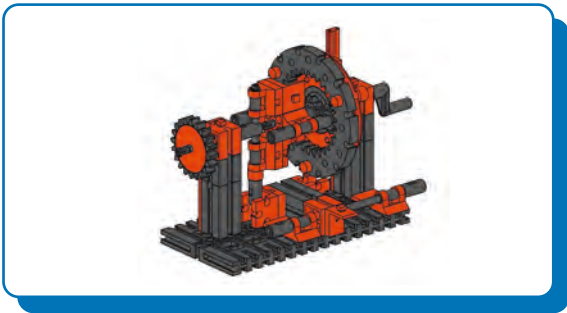



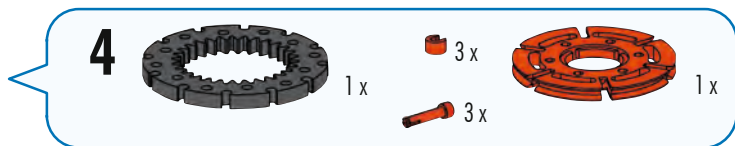
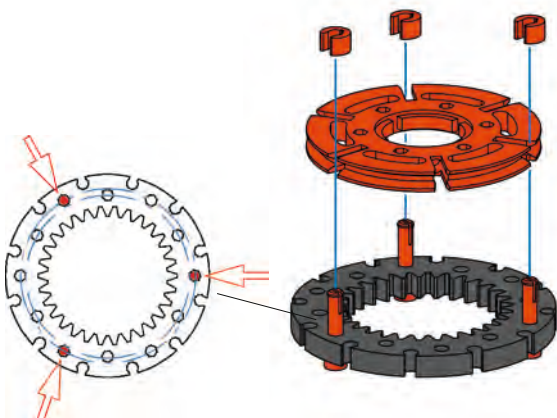
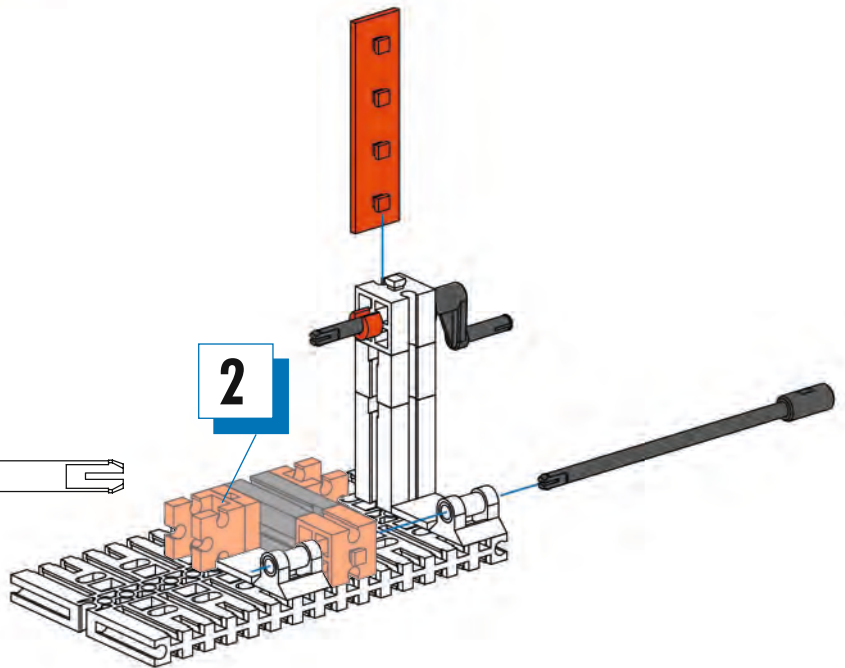
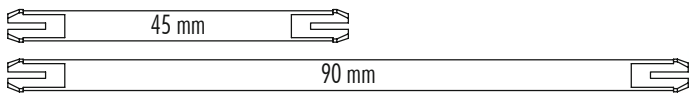
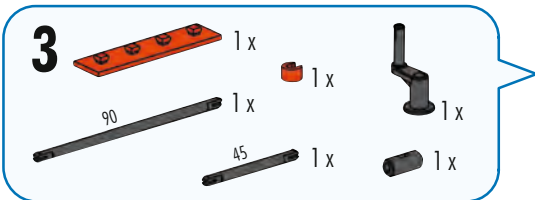
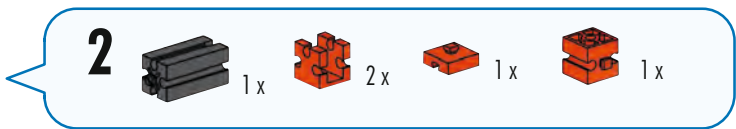
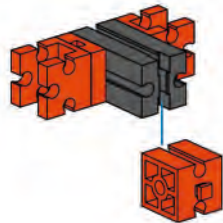
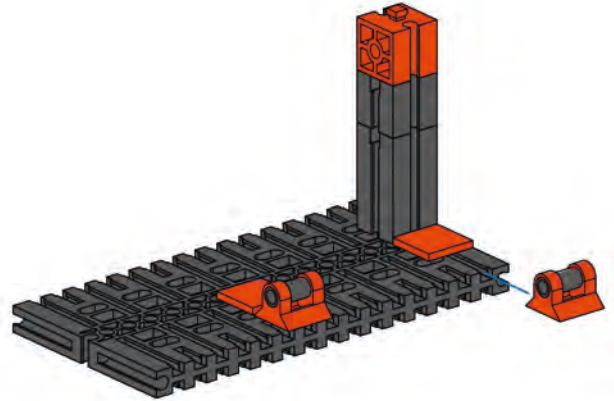
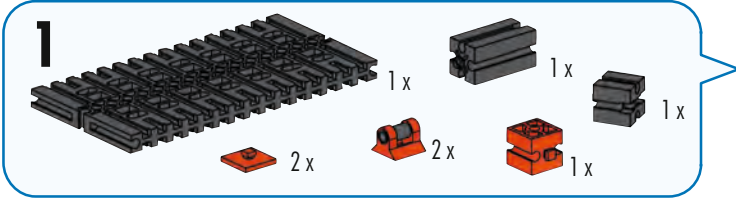

**Planetengetriebe**  
**Planetary gear**  
**Engrenage planétaire**

**Planeetwieloverbrenging**  
**Engranaje planetario**  
**Engrenagem planetária**

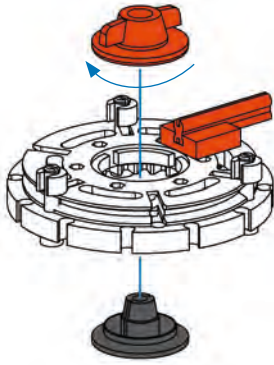
**Rotismo epicicloidale**  
**Планетарный редуктор**  
**行星齿轮机构**







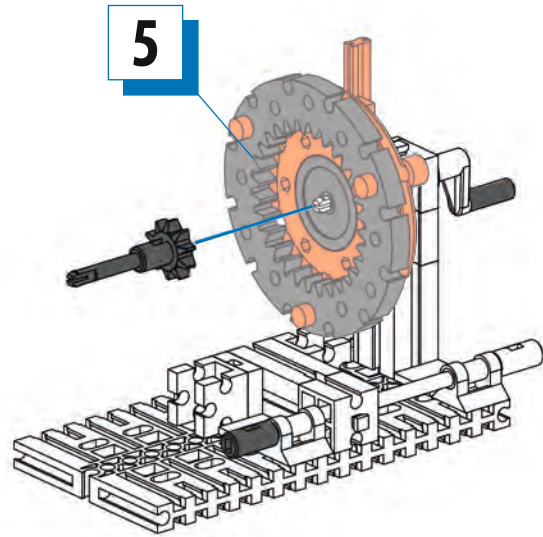



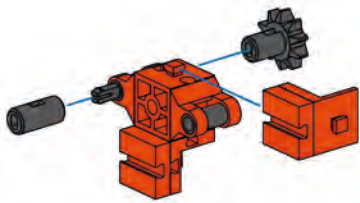
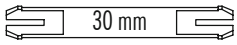

- 5**  1x  1x  1x  1x



- 6**  1x  1x  1x  1x



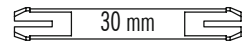

- 7**  1x  2x  2x  1x  1x  2x  1x



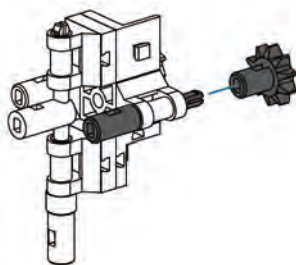
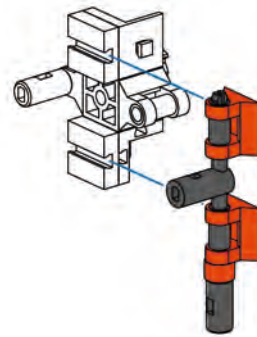
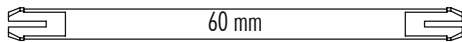

- 8**  2x  1x  1x  1x



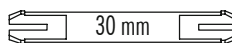

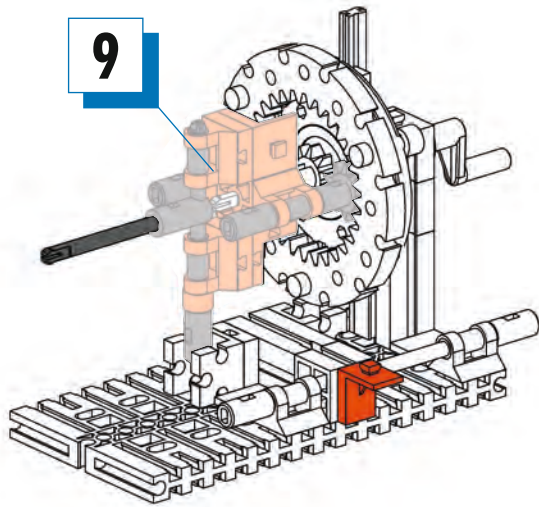



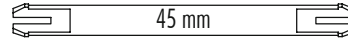

- 9**  1x  1x  1x





**10**  1x  1x



**11**  1x  1x  1x   
 1x  1x  1x

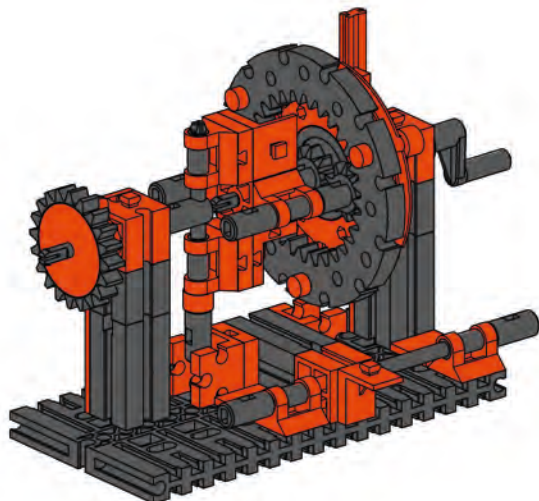
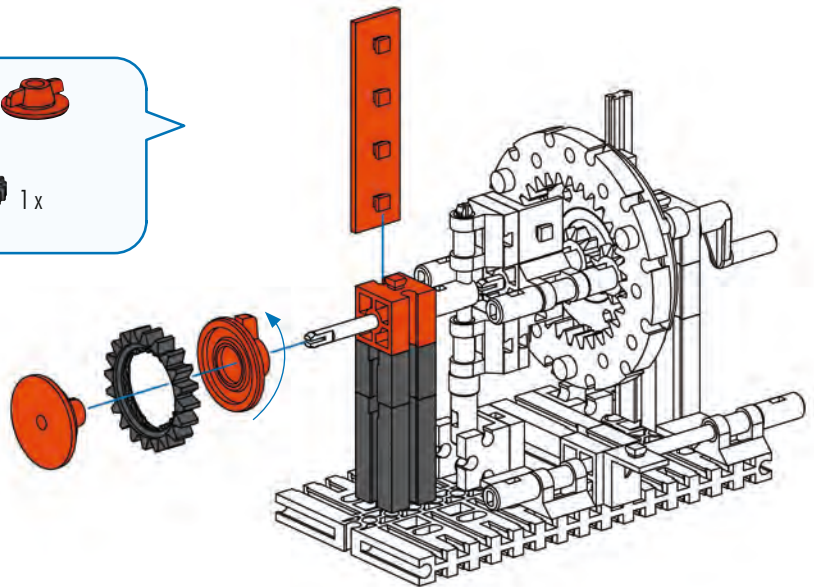

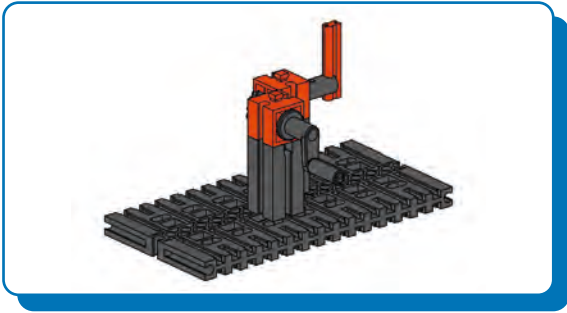

**Kegelradgetriebe**      **Conische tandwieloverbrenging**      **Ingranaggio conico**  
**Bevel gear**            **Engranaje de ruedas cónicas**      **Конический редуктор**  
**Engrenage à pignon conique**      **Engrenagem cónica**      **锥齿轮传动机构**

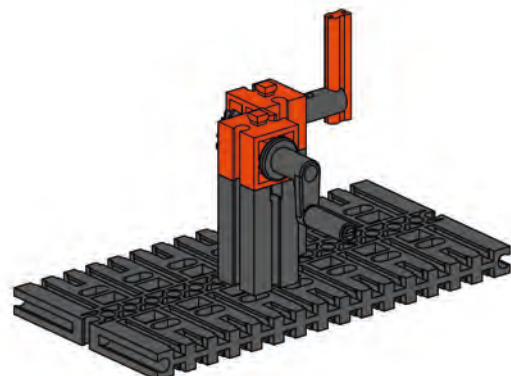
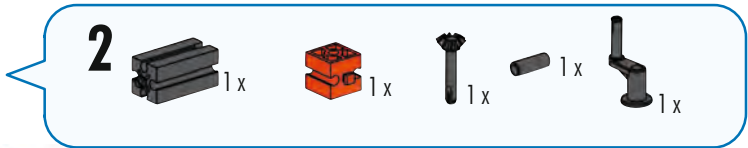
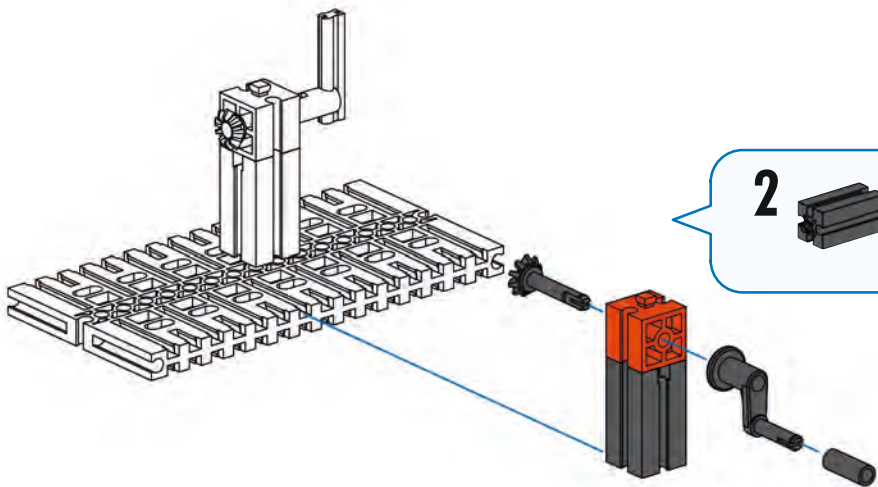
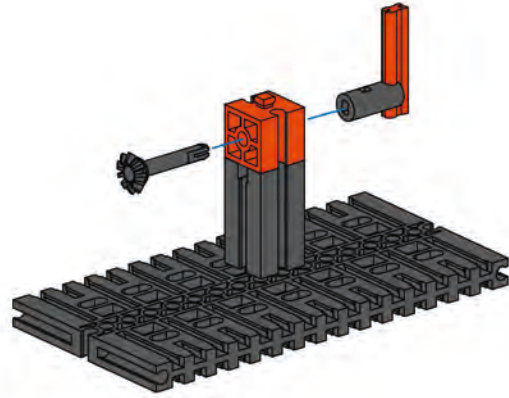
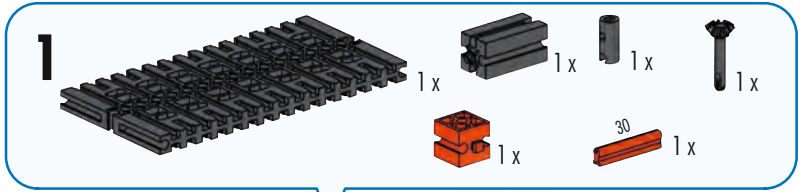

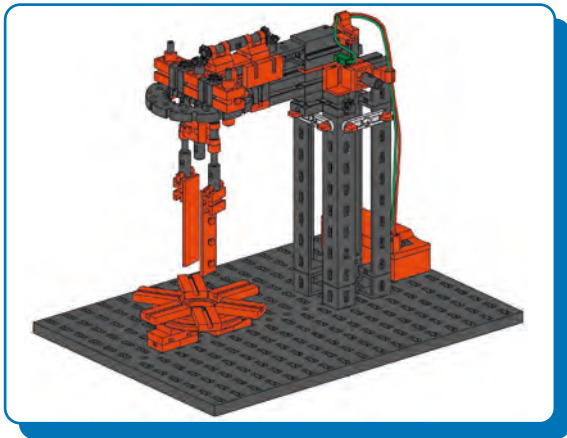

Küchenmaschine  
Kitchen appliance  
Robot ménager

Keukenmachine  
Máquina de cocina  
Máquinas de cozinha

Robot da cucina  
Кухонный комбайн  
电动厨具

1

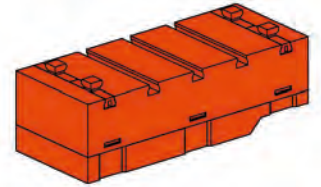
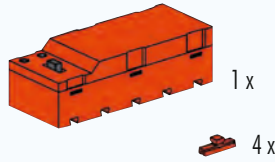

2

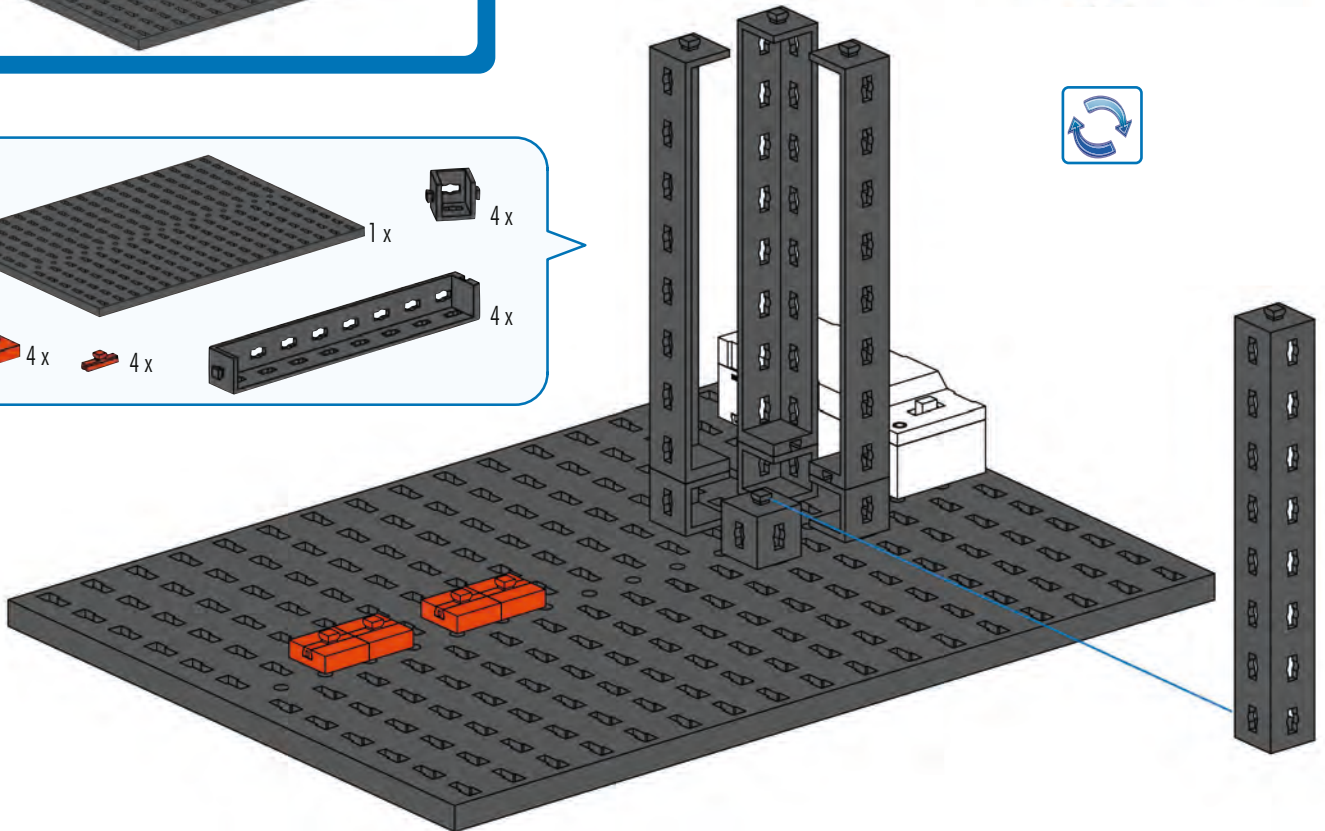
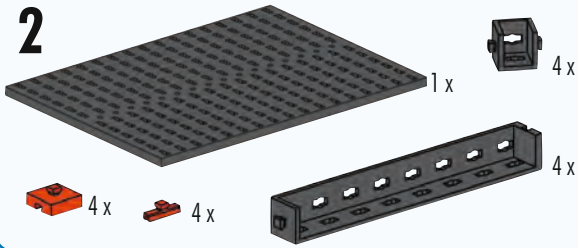

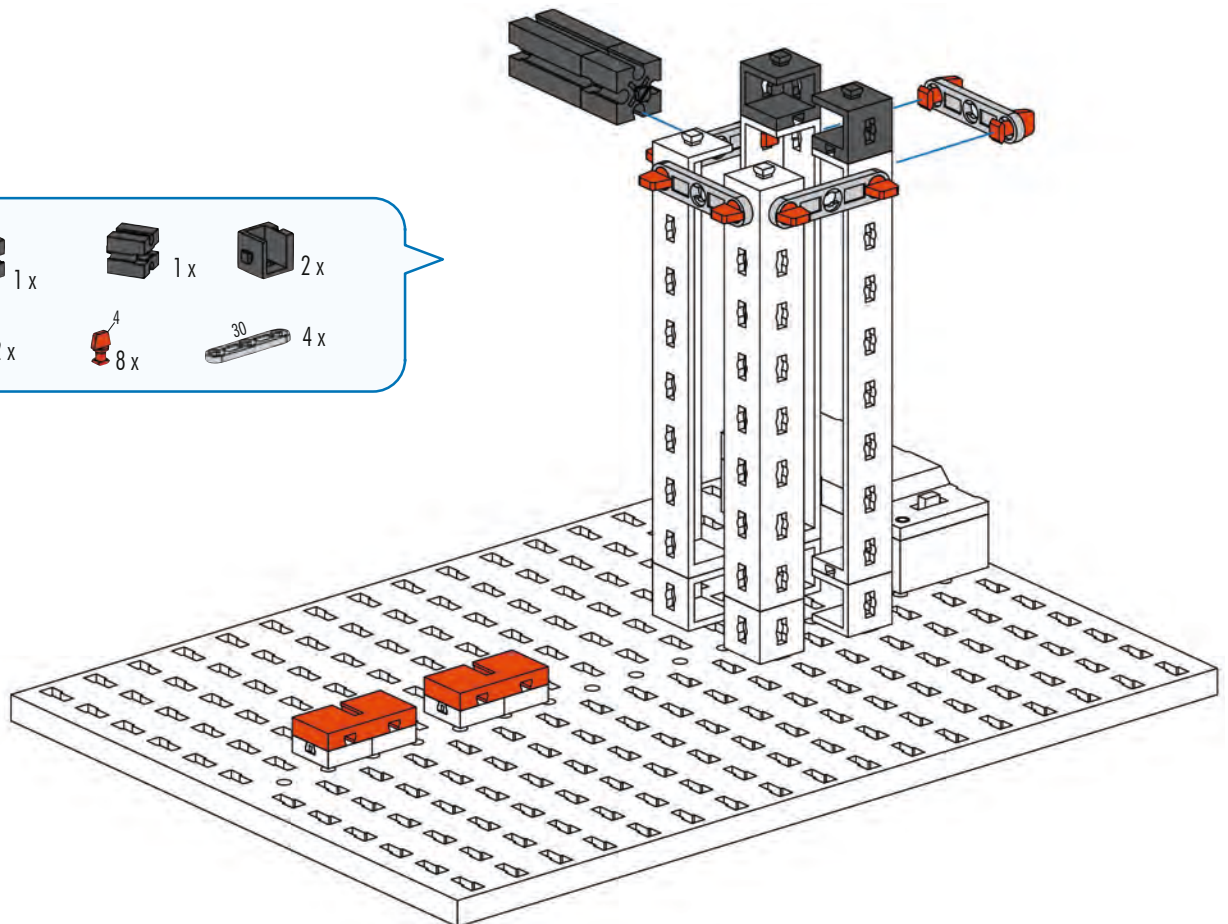
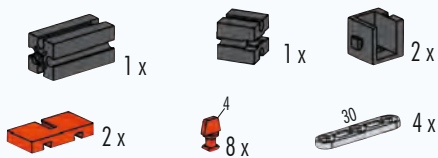

3









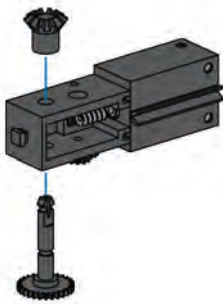
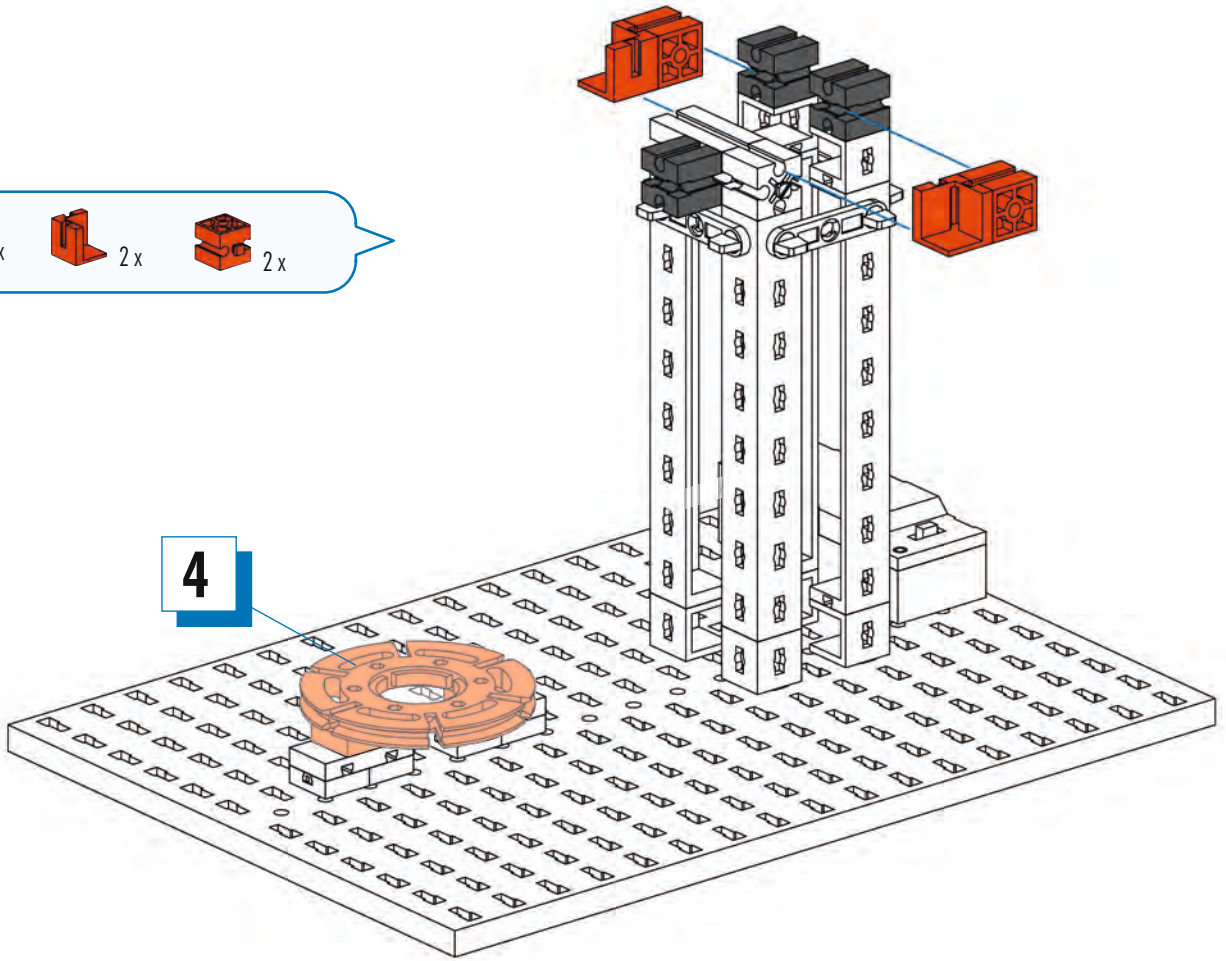



**4**  1x  2x

**5**  3x  2x  2x



**6**  1x  1x  1x  1x

**7**  2x  1x  1x  2x

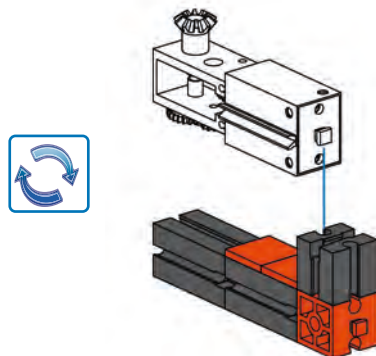

7

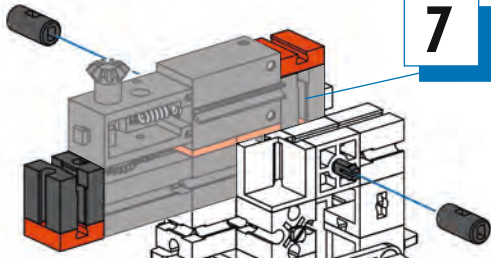

- 8**
- 1 x [Black 1x2 Technic Brick]
  - 2 x [Red 1x2 Technic Brick]
  - 6 x [Red 1x3 Technic Brick]
  - 1 x [Black Pin 60]
  - 2 x [Black Pin]

60 mm

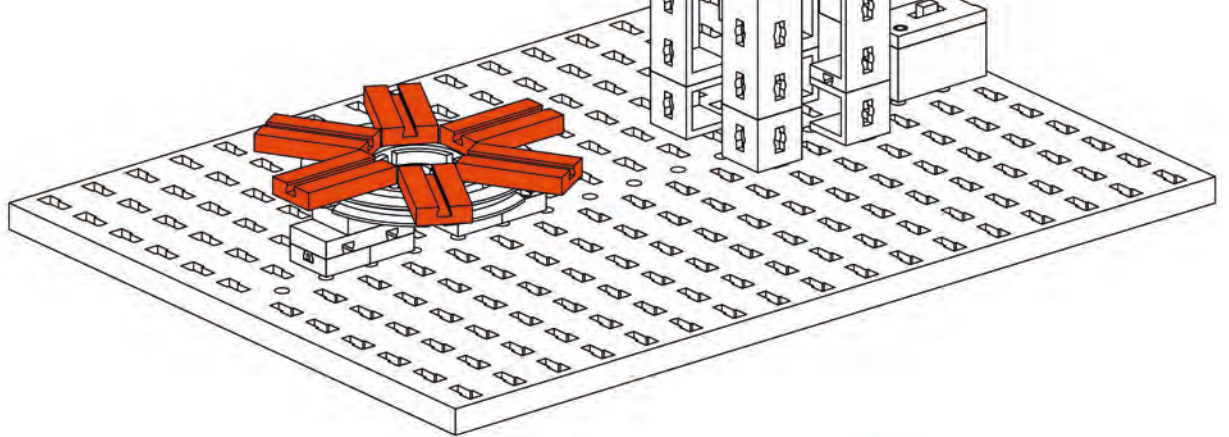

9

- 1 x [Grey Gear 40]
- 2 x [Black Pin 40]
- 2 x [Red 1x2 Technic Brick]
- 4 x [Red Pin]

40 mm

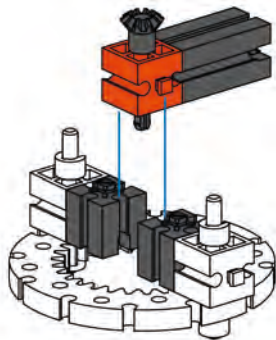
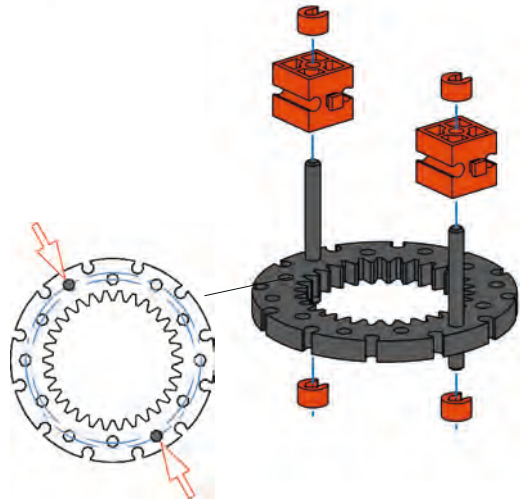

10

- 1 x [Black 1x2 Technic Brick]
- 2 x [Black 1x2 Technic Brick]
- 1 x [Red 1x2 Technic Brick]
- 1 x [Black Pin 30]
- 1 x [Black Pin]

30 mm



**11**

- 1x (Red 1x2 Technic Brick)
- 2x (Grey 45 Technic Pin)
- 2x (Red 1x2 Technic Pin)
- 2x (Red 1x2 Technic Pin)
- 2x (Grey Technic Pin)

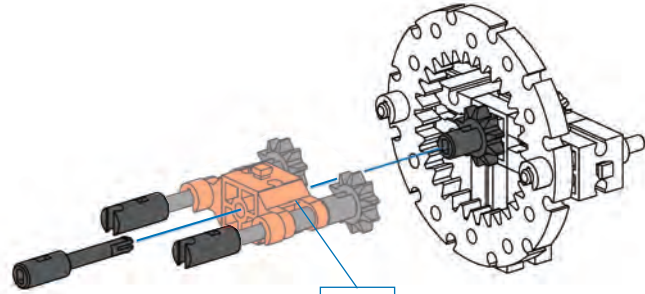
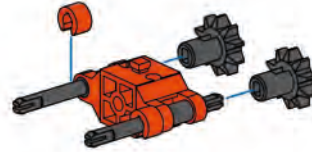
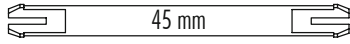

**11**

**12**

- 1x (Grey Technic Pin)
- 1x (Grey 30 Technic Pin)
- 1x (Grey Technic Pin)
- 2x (Grey Technic Pin)

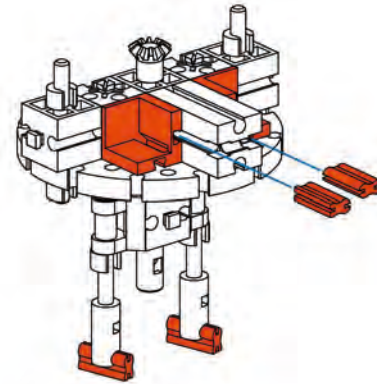
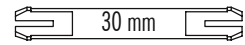

**13**

- 2x (Red 1x2 Technic Pin)
- 4x (Red 1x2 Technic Pin)

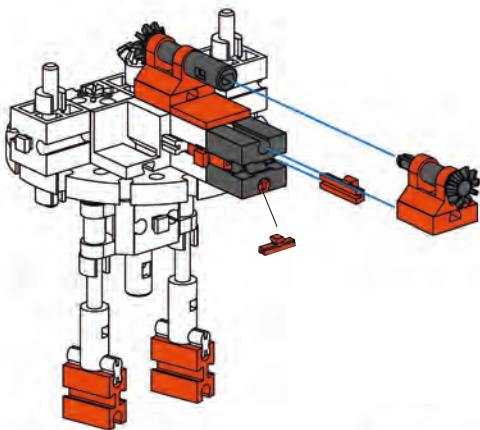

**14**

- 2x (Red 1x2 Technic Pin)
- 2x (Red 1x2 Technic Pin)
- 1x (Grey Technic Pin)
- 2x (Grey Technic Pin)
- 2x (Red 1x2 Technic Pin)
- 1x (Red 1x2 Technic Pin)
- 3x (Red 1x2 Technic Pin)
- 1x (Grey Technic Pin)

**14**

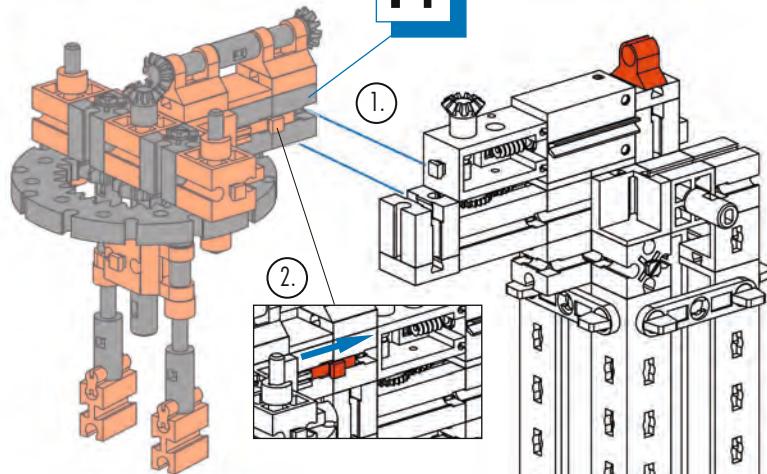

**15**

- 1x (Red 1x2 Technic Pin)

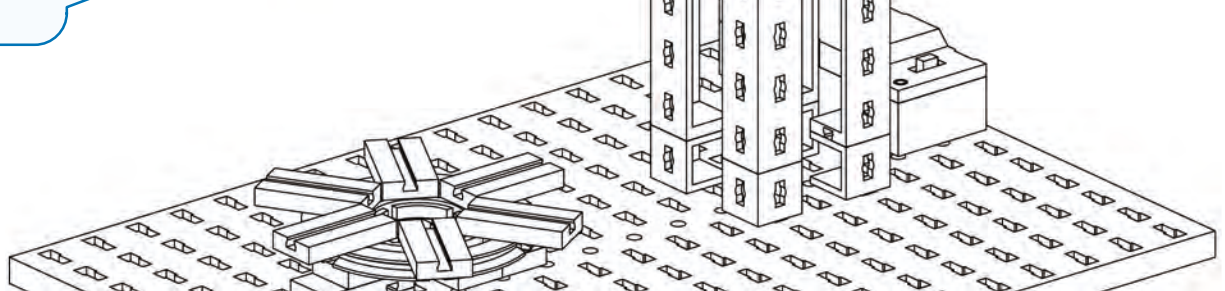

**16**  2x  2x  1x

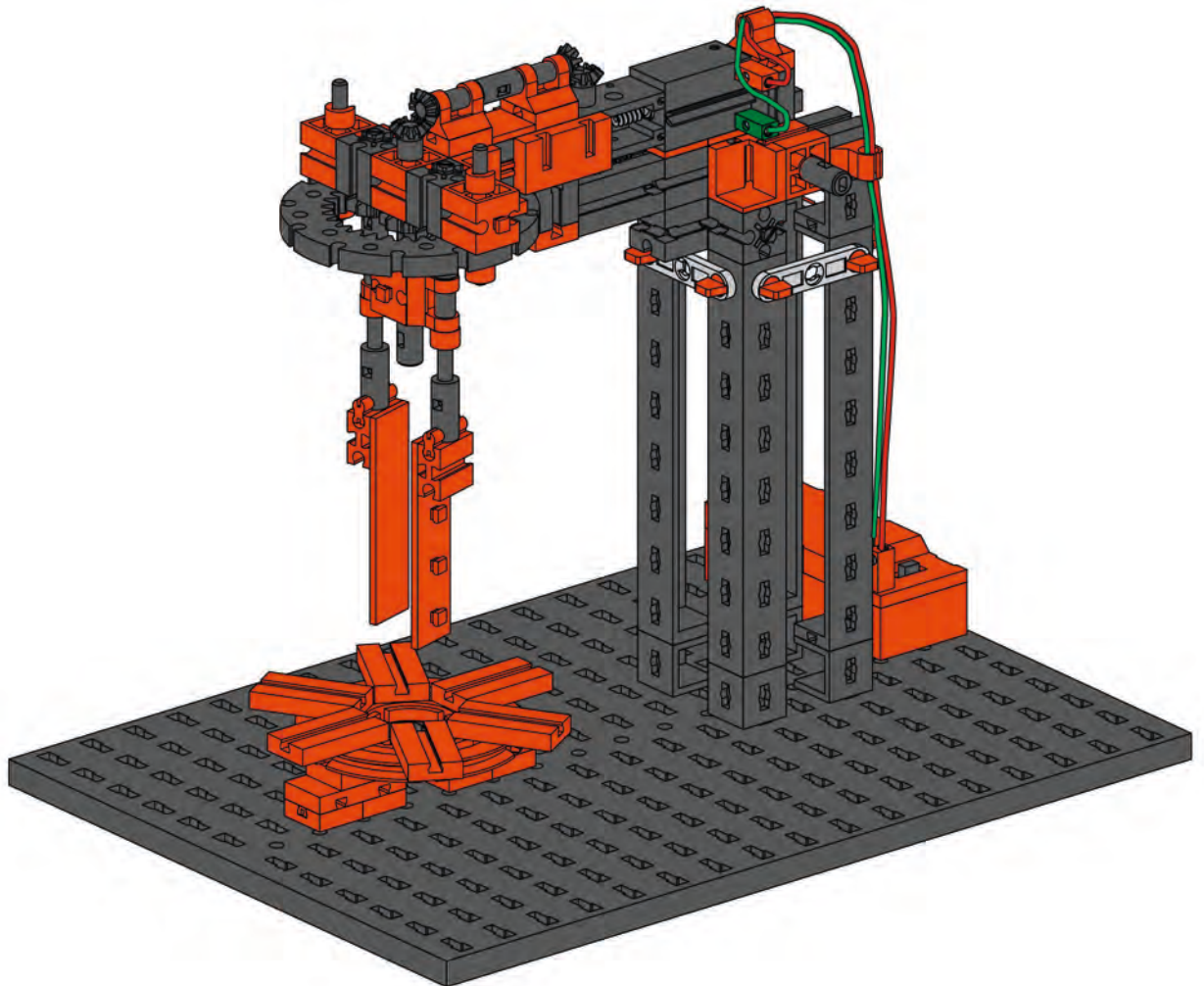
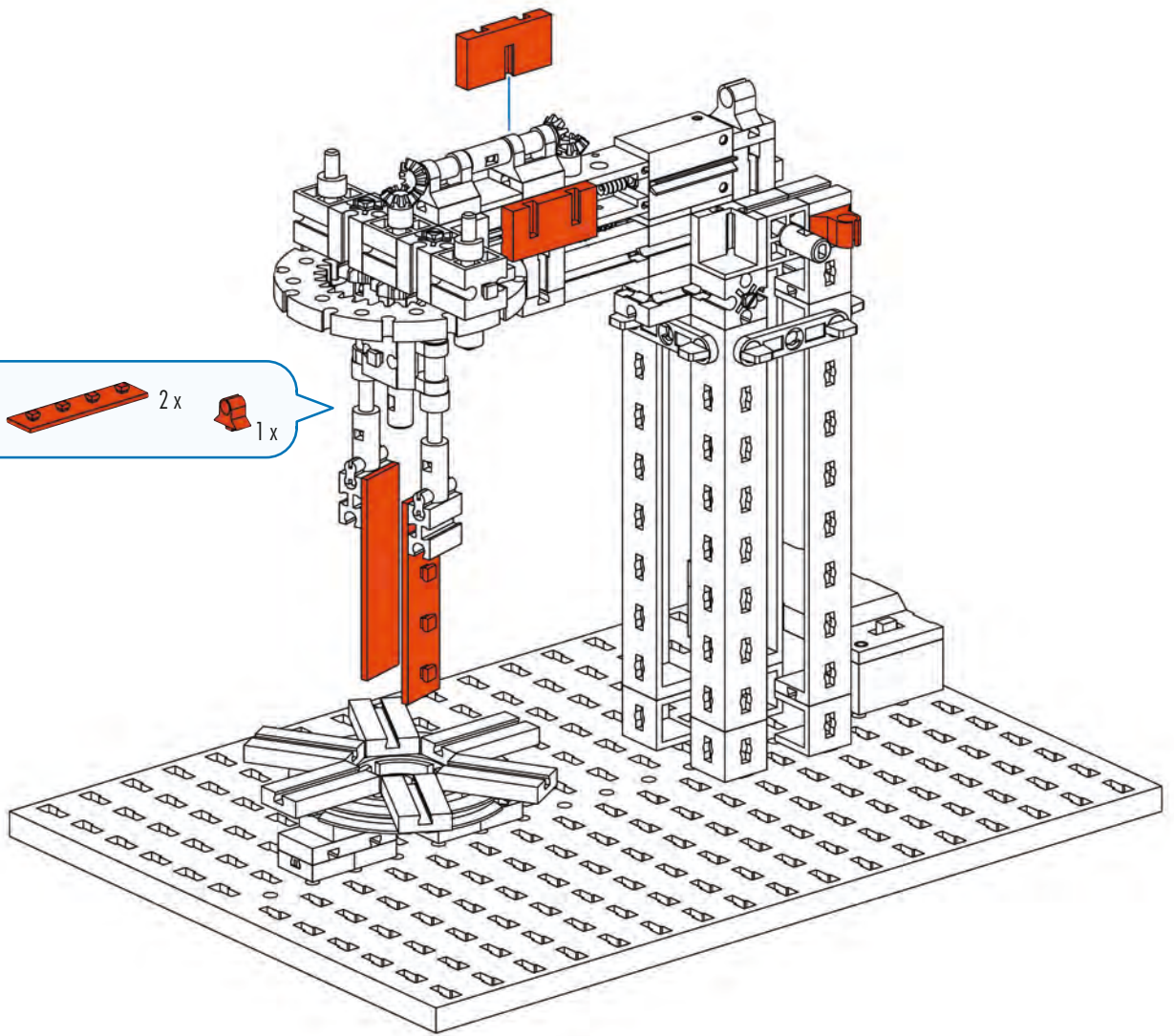

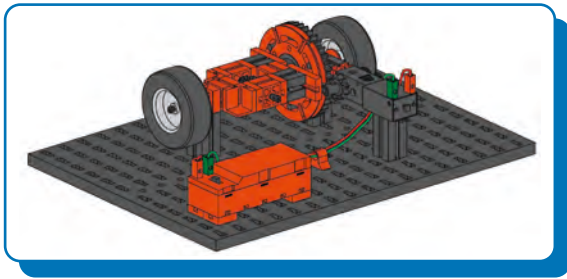





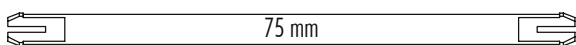
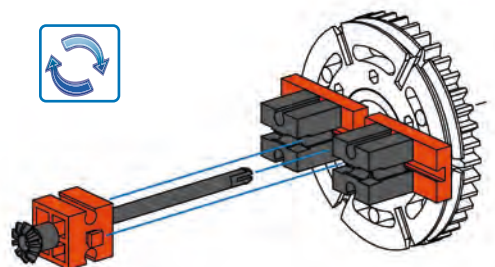
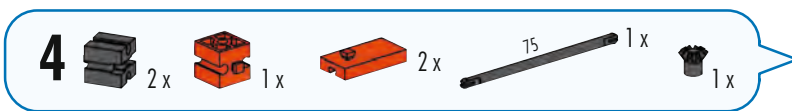
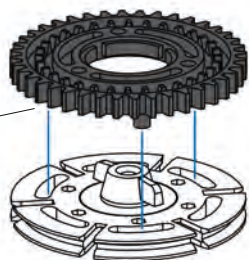
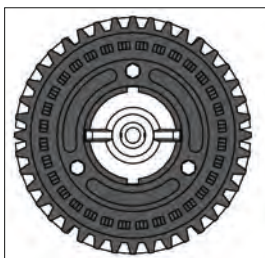
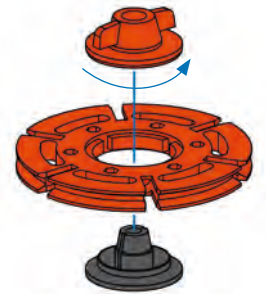
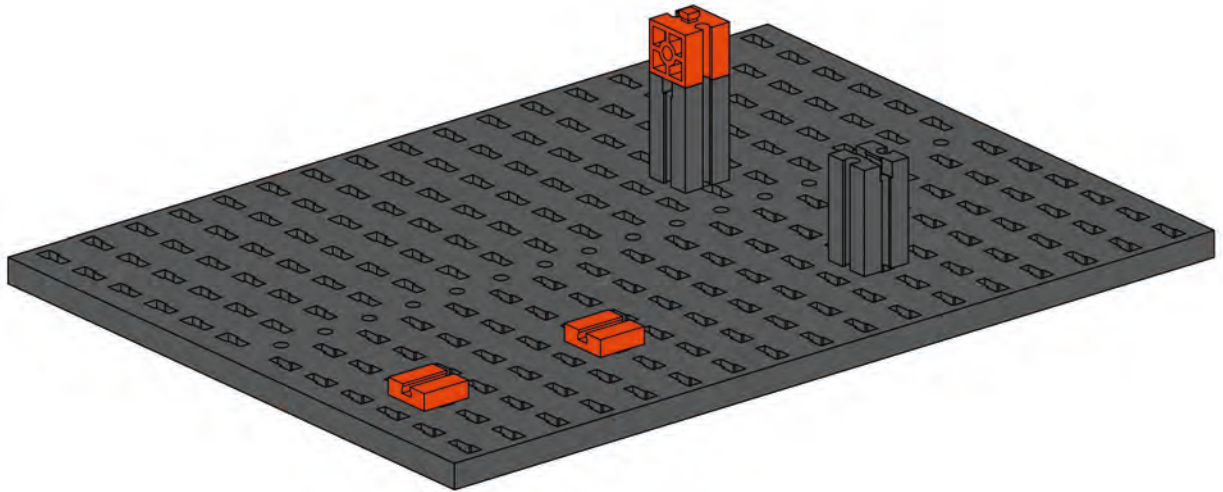
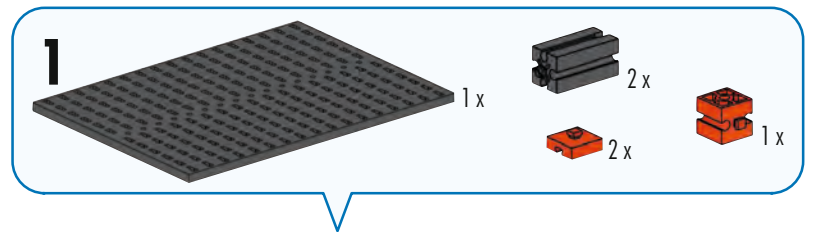

Differentialgetriebe  
Differential gear  
Engrenage différentiel





Differentieel  
Engranaje diferencial  
Transmissão diferencial

Differenziale  
Дифференциал  
差速机构

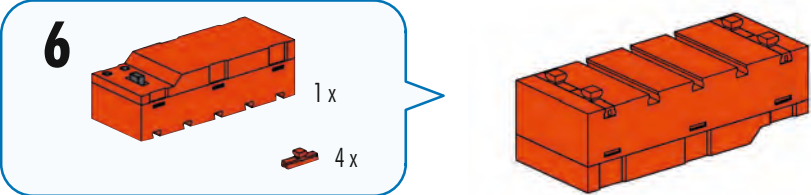
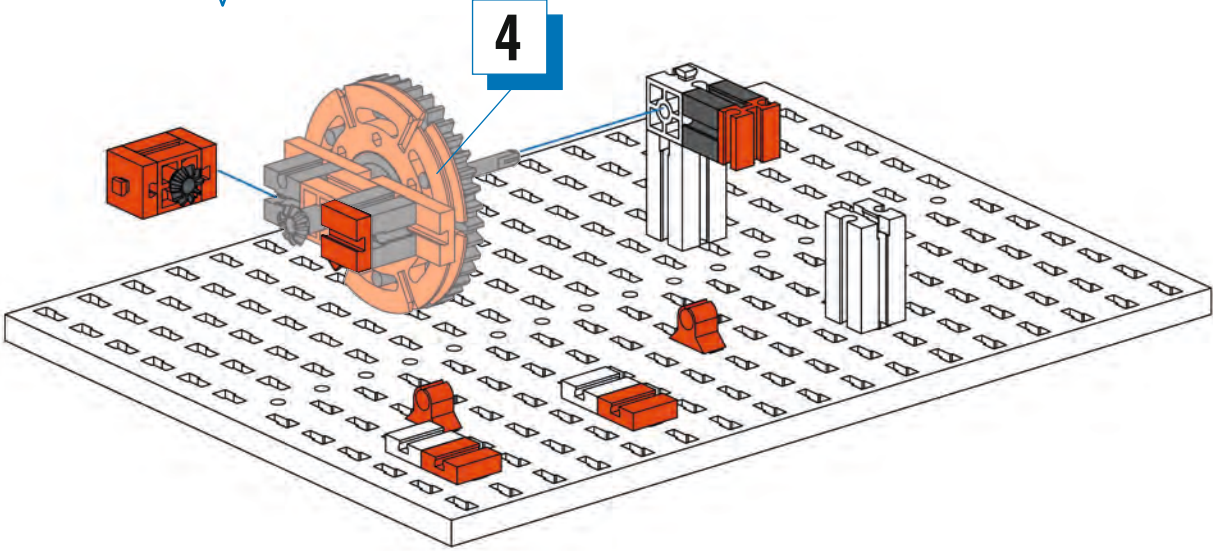

- 5**  1x  5x  2x  1x  1x  1x

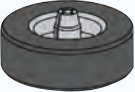

- 7**  1x  1x  60 1x  1x  1x  1x

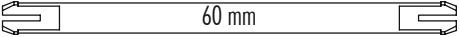
 60 mm

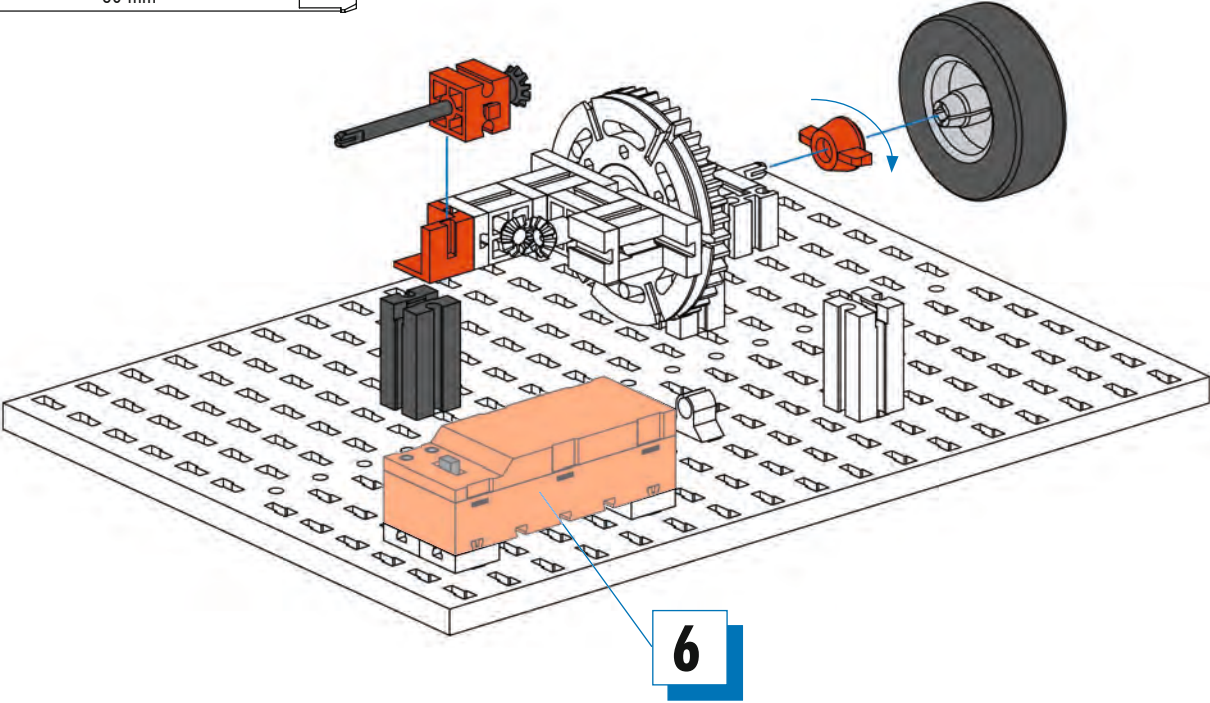

8



1x



1x



1x



1x



2x

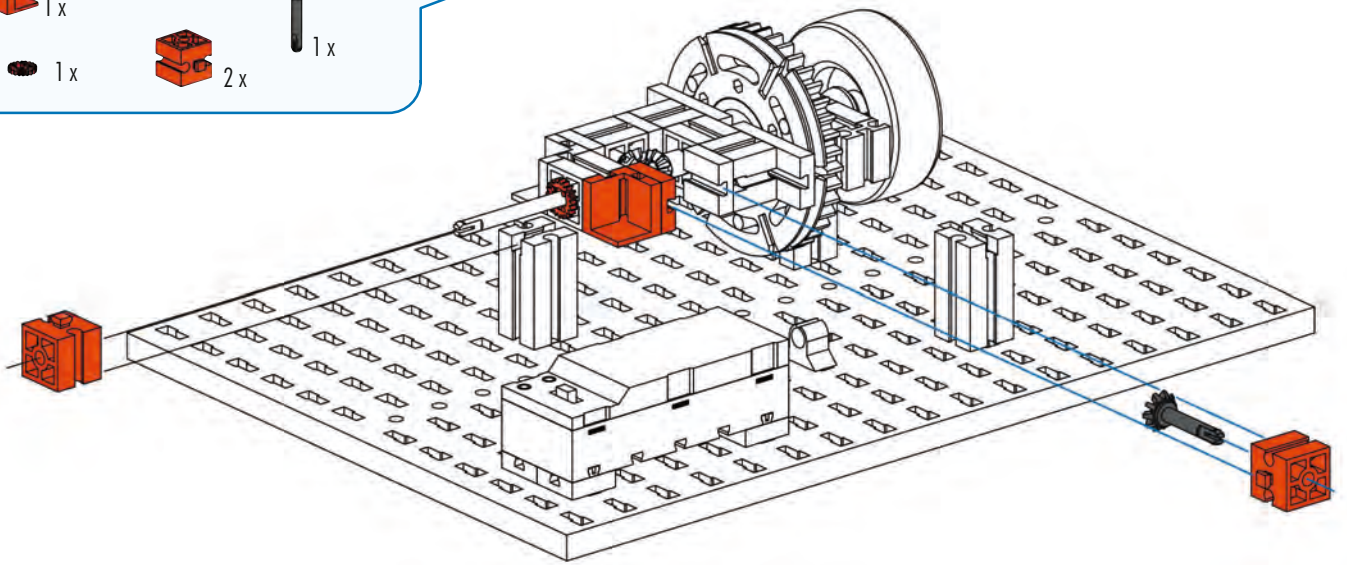

9

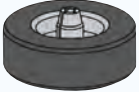

1x



1x



1x



1x



1x

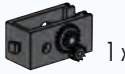

1x

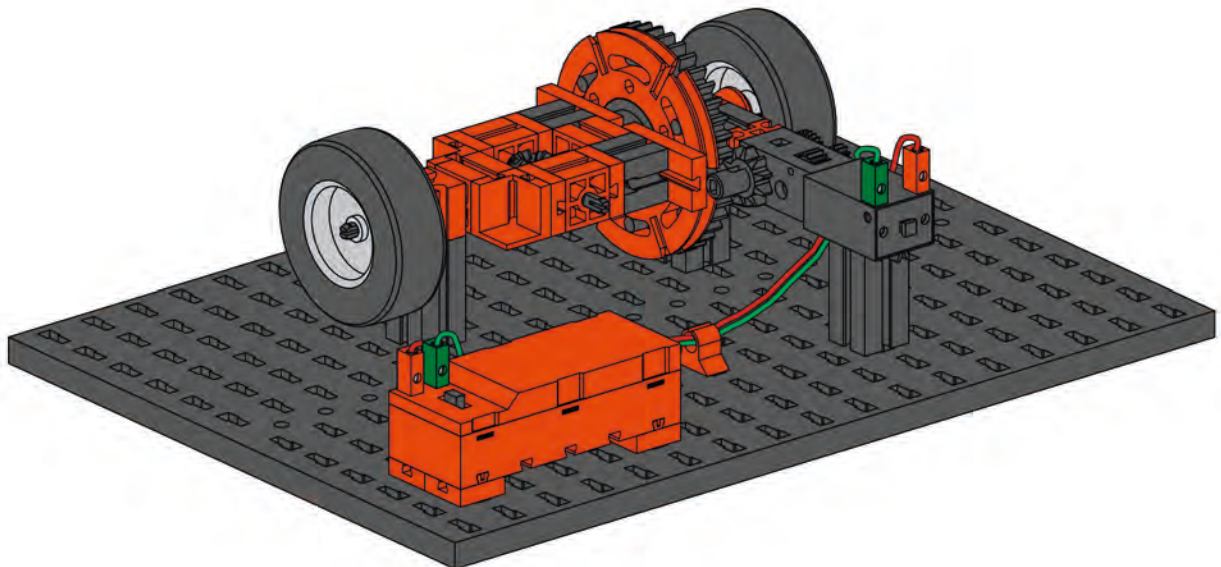
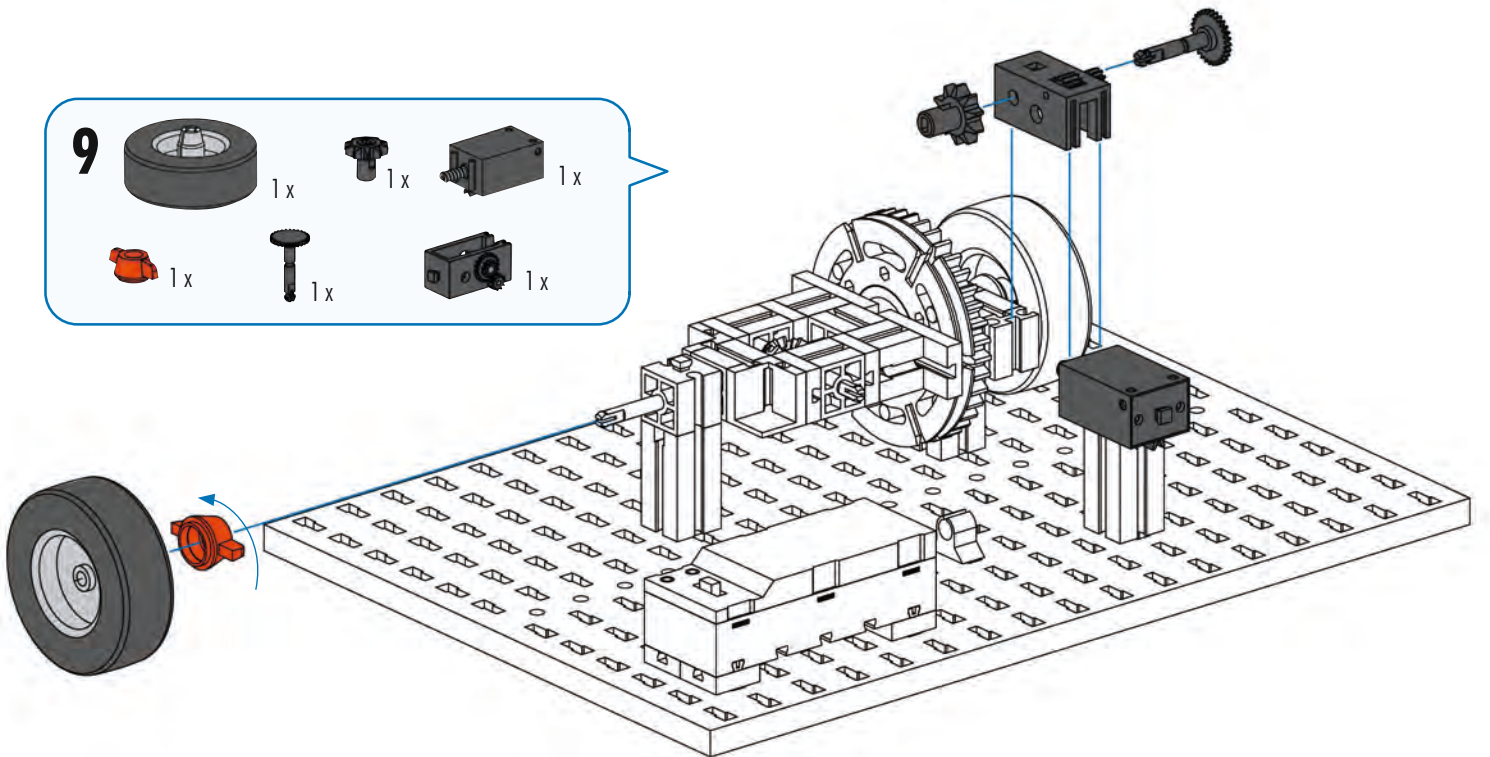



Scherenhubtisch mit Lenkung  
 Scissor lift table with steering system  
 Table élévatrice à ciseaux avec renvoi de direction

Schaarheftafel met stuur  
 Mesa elevadora de tijera con dirección  
 Mesa elevatória de tesouras com direção

Elevatore a pantografo con sterzo  
 Ножничный подъёмный стол на тележке  
 带转向机构的剪式升降台

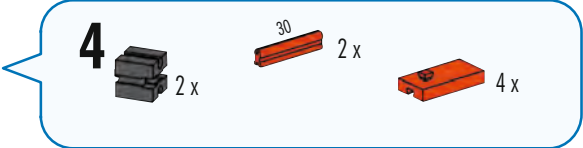
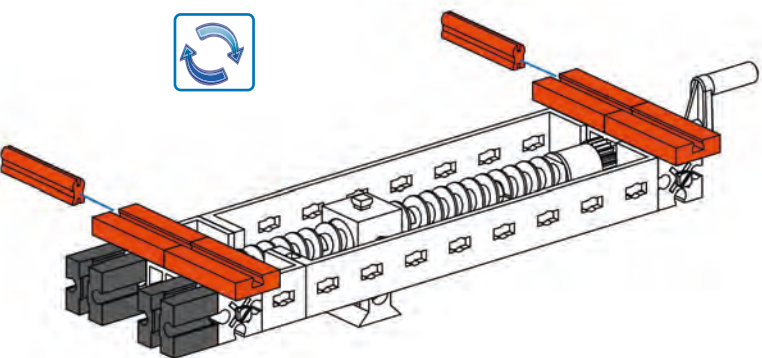
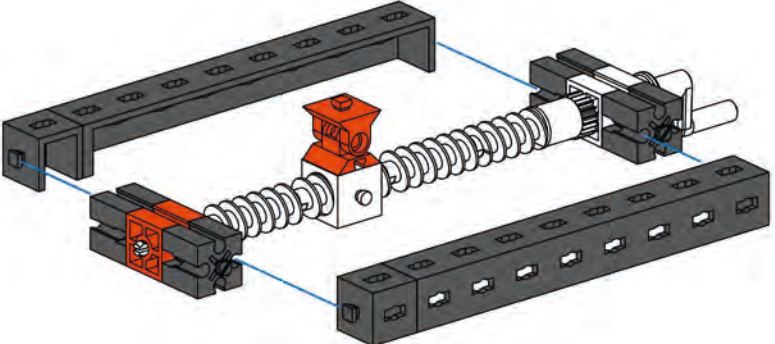
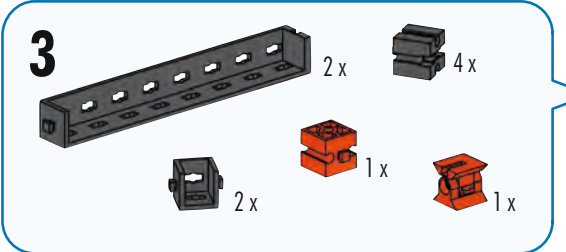
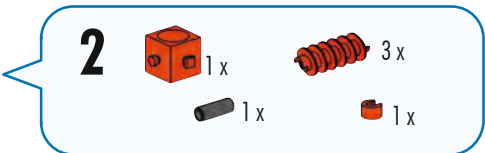
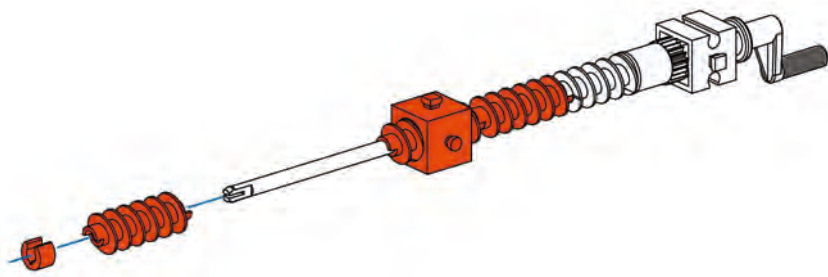
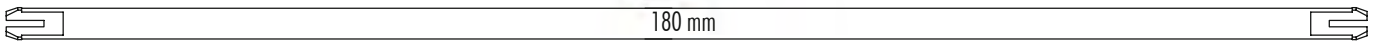
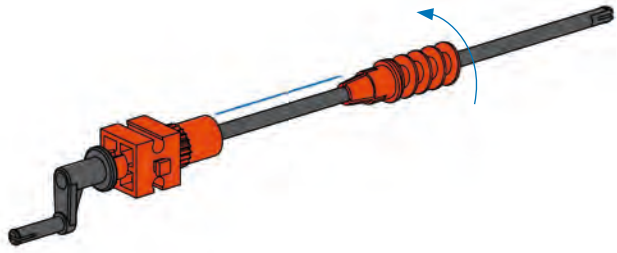
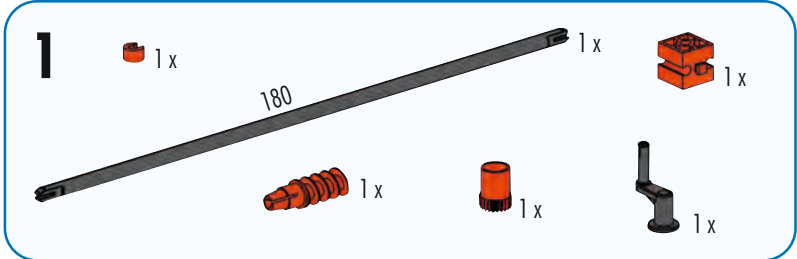

5

8x 2x 2x

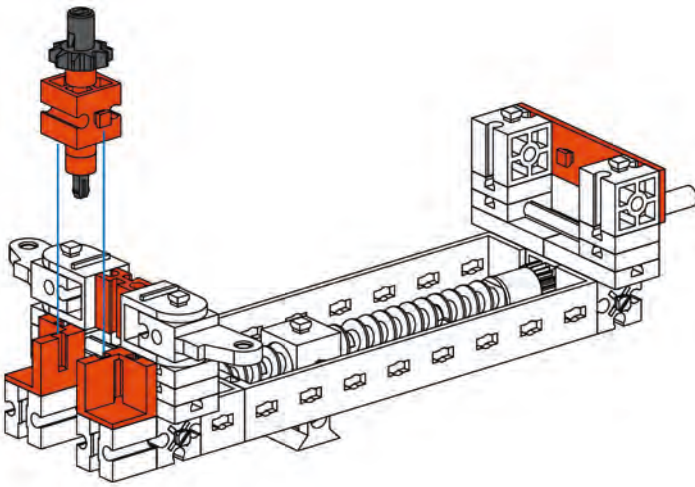
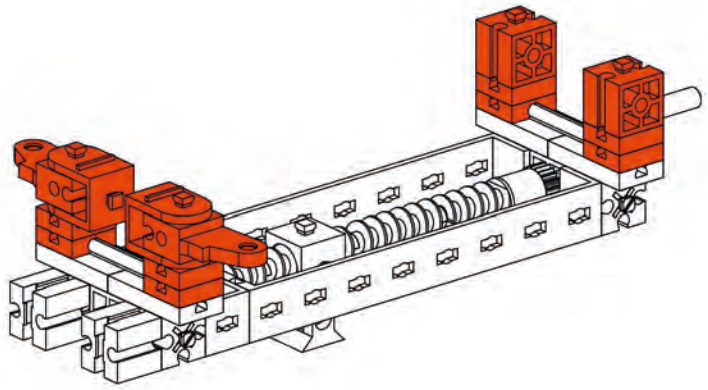

6

2x 1x 1x 1x 3x 1x

45 mm

7

30 1x 1x 15 1x 1x 1x

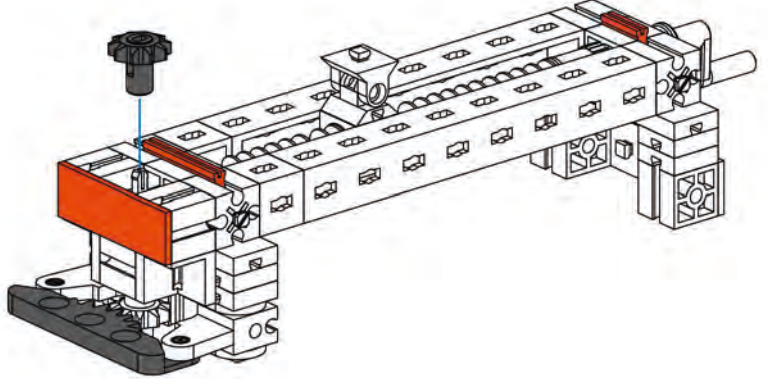

8

2x 2x 1x 1x

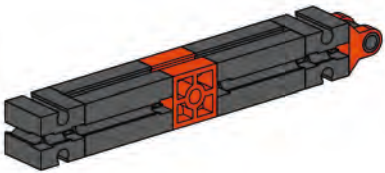

8

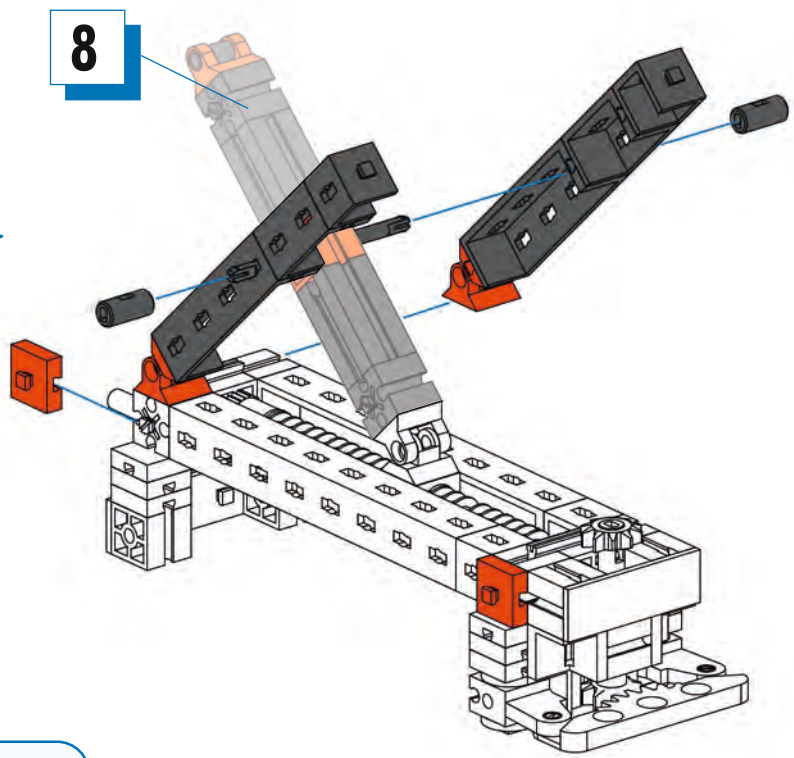

9

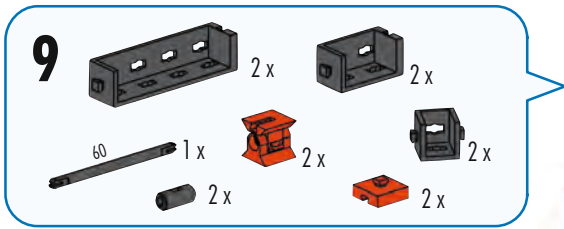

60 mm

10

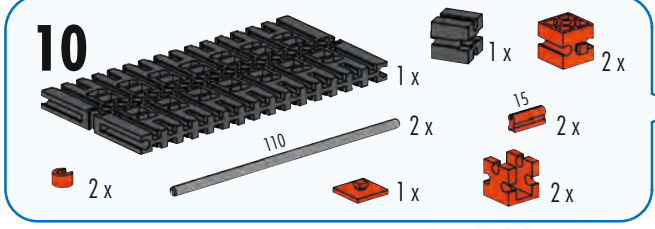

110 mm

10

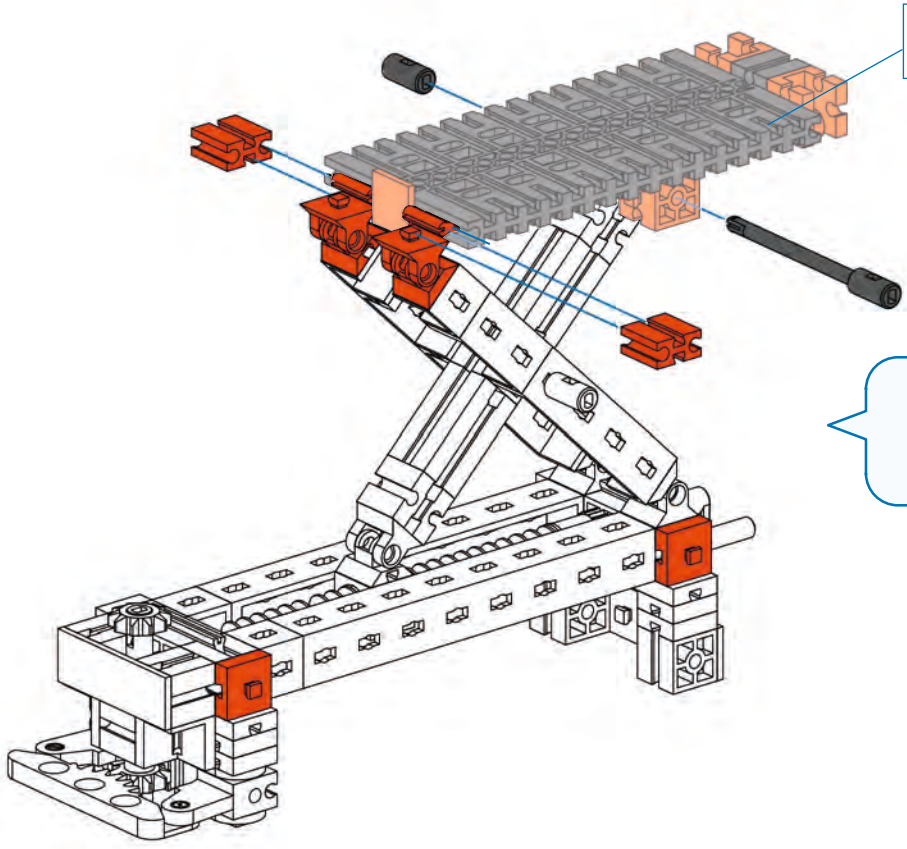

11

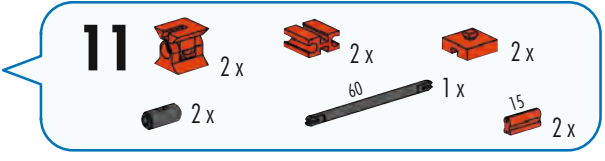

60 mm



12

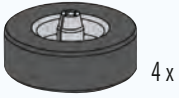

4 x



4 x



2 x



1 x



2 x



2 x



10 x



2 x



2 x

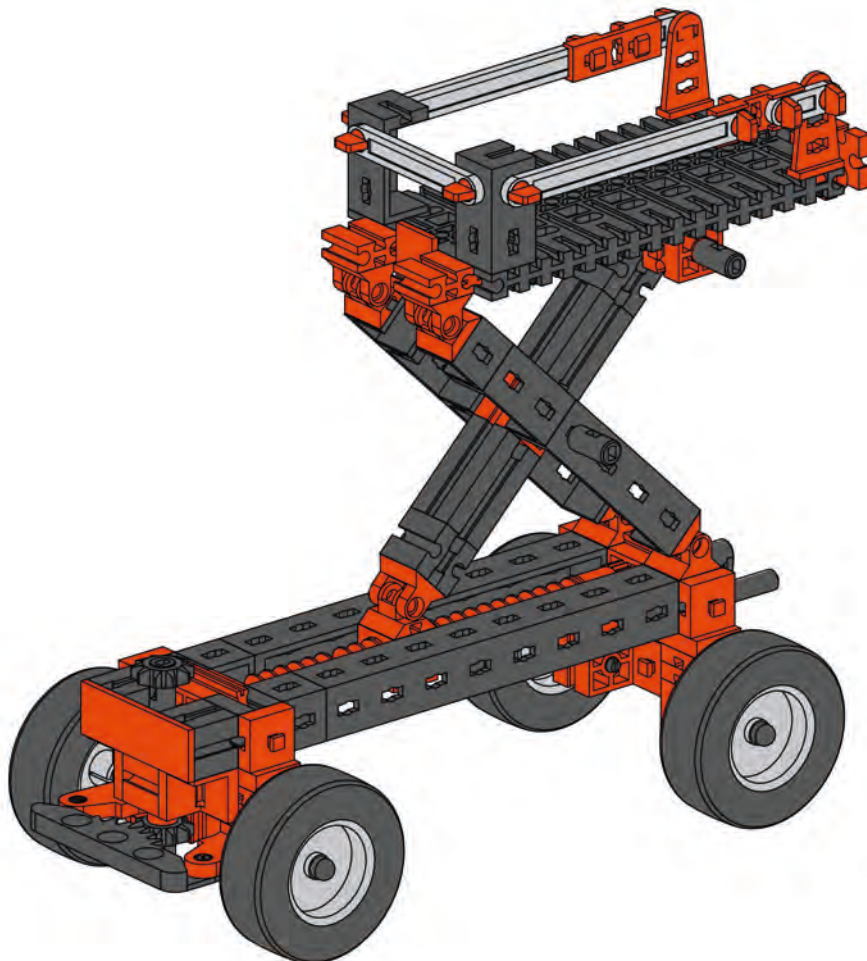
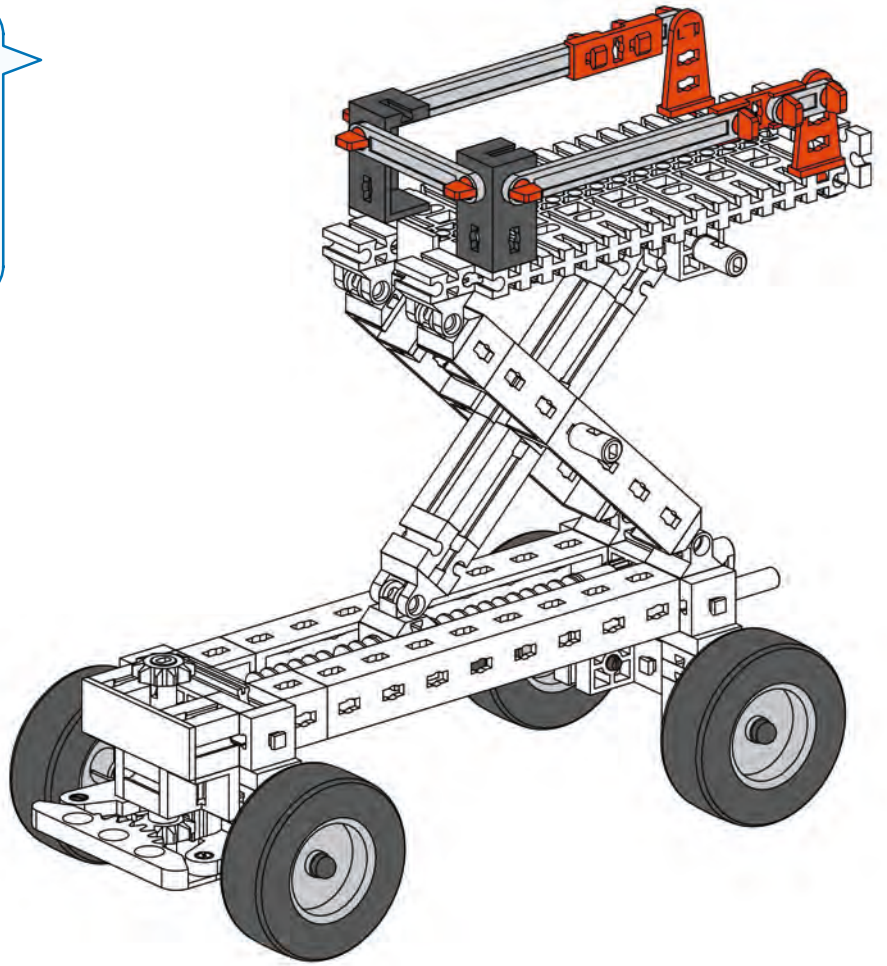

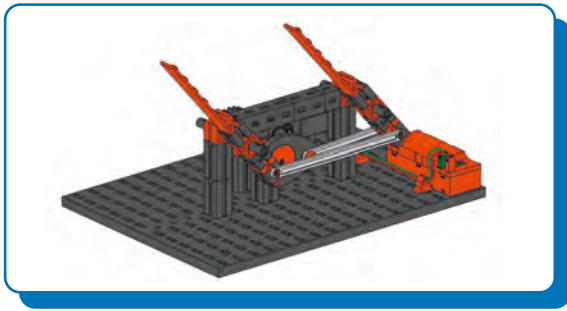

**Scheibenwischer**  
**Windshield wiper**  
**Essuie-glace**

**Ruitenwischer**  
**Limpiaparabrisas**  
**Para-brisas**

**Tergicristallo**  
**теклоочистители**  
**刮雨器**

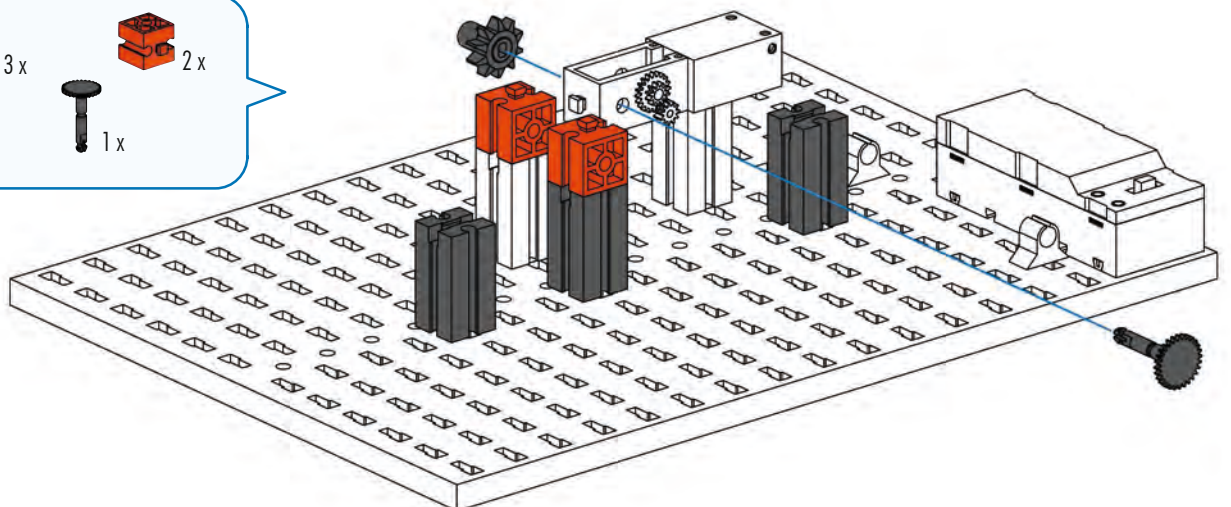
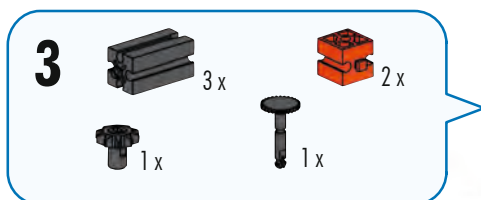
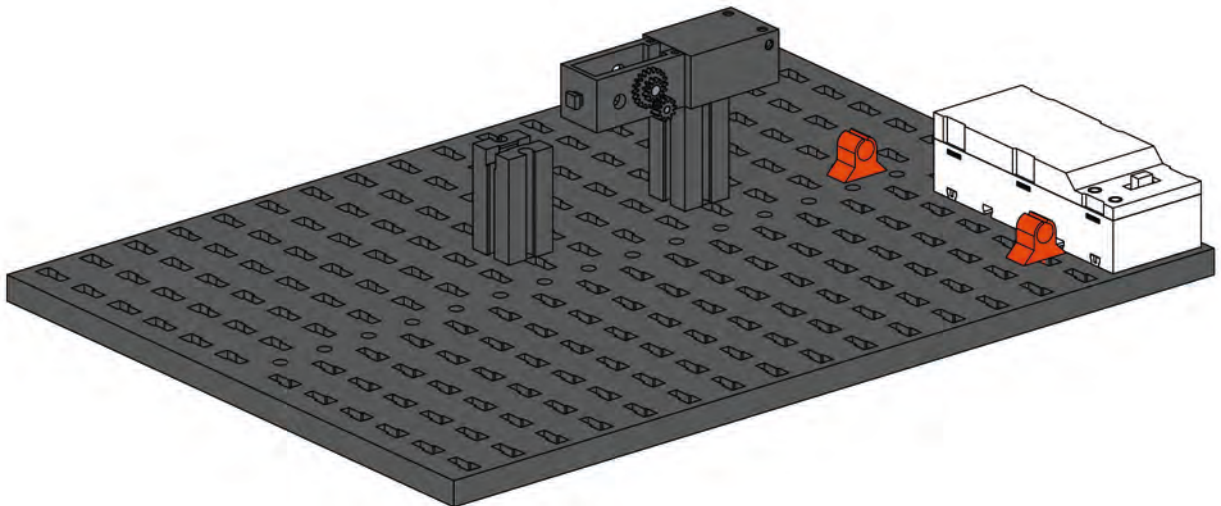
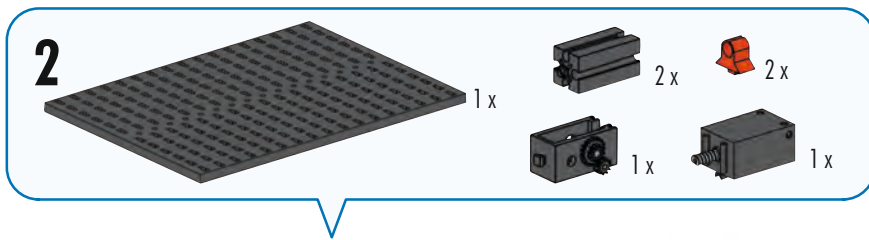
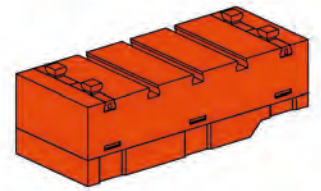
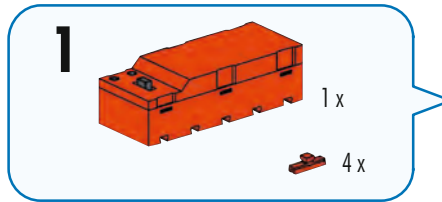

4

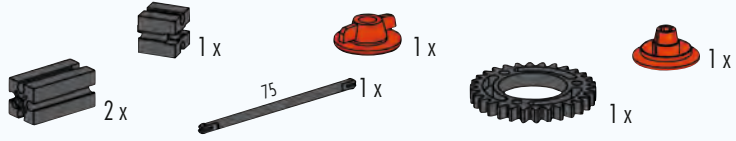

75

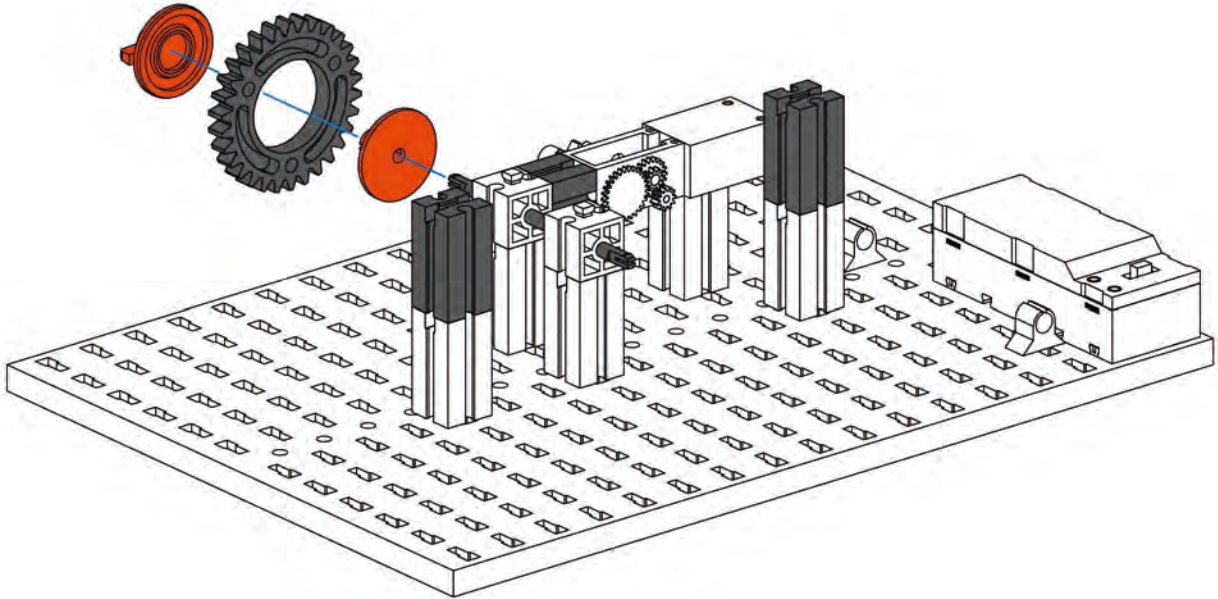
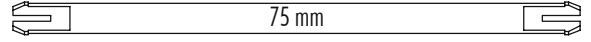

5

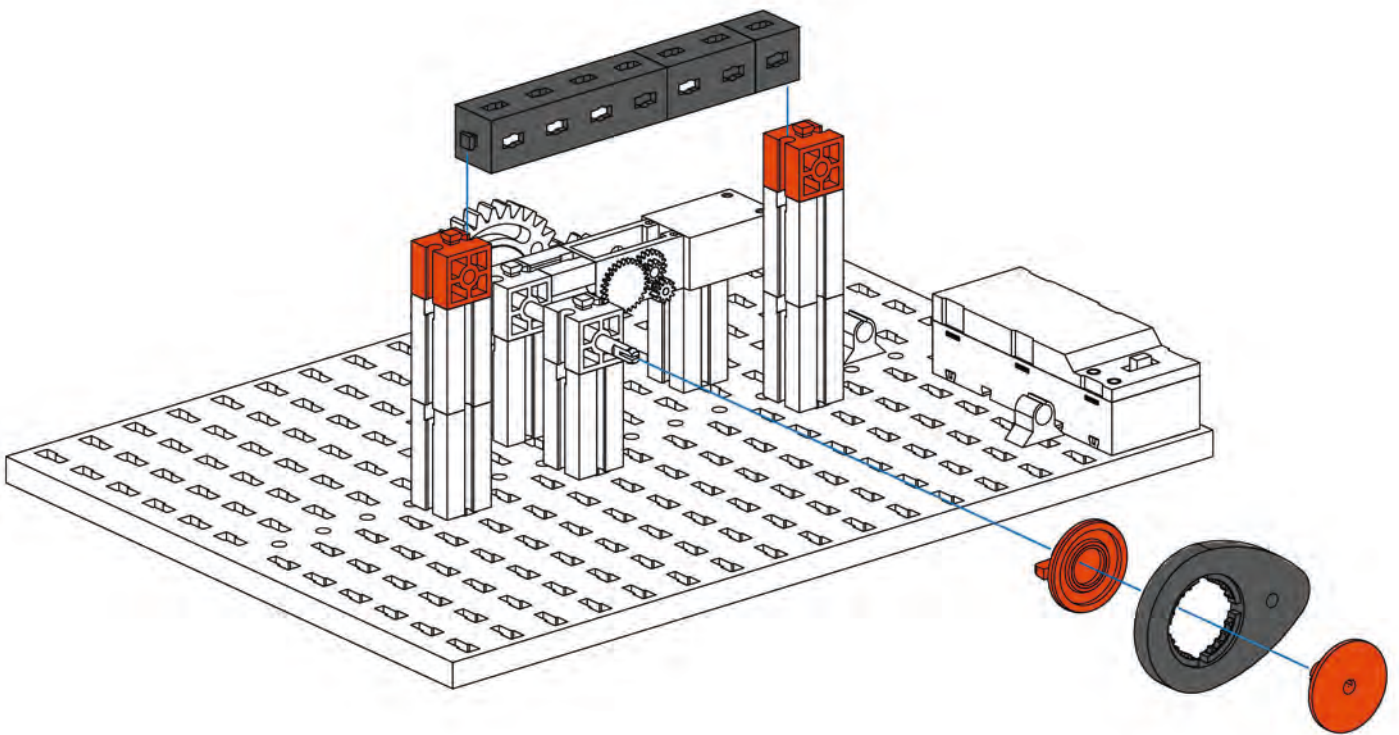
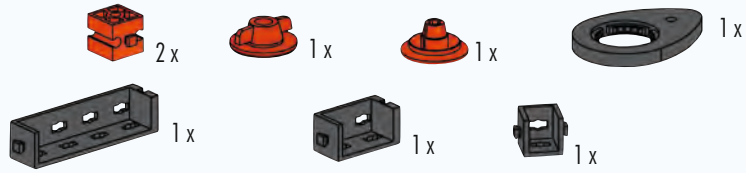

**6**

- 3x [Grey 1x3 Technic Brick]
- 1x [Red 1x3 Technic Brick]
- 1x [Red 1x2 Technic Brick]
- 1x [Red 1x5 Technic Beam]
- 2x [Red Technic Pin]

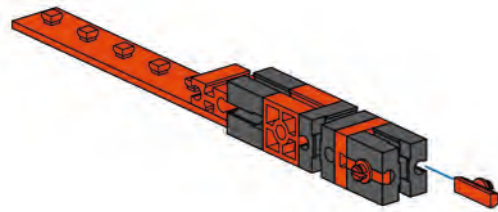

**7**

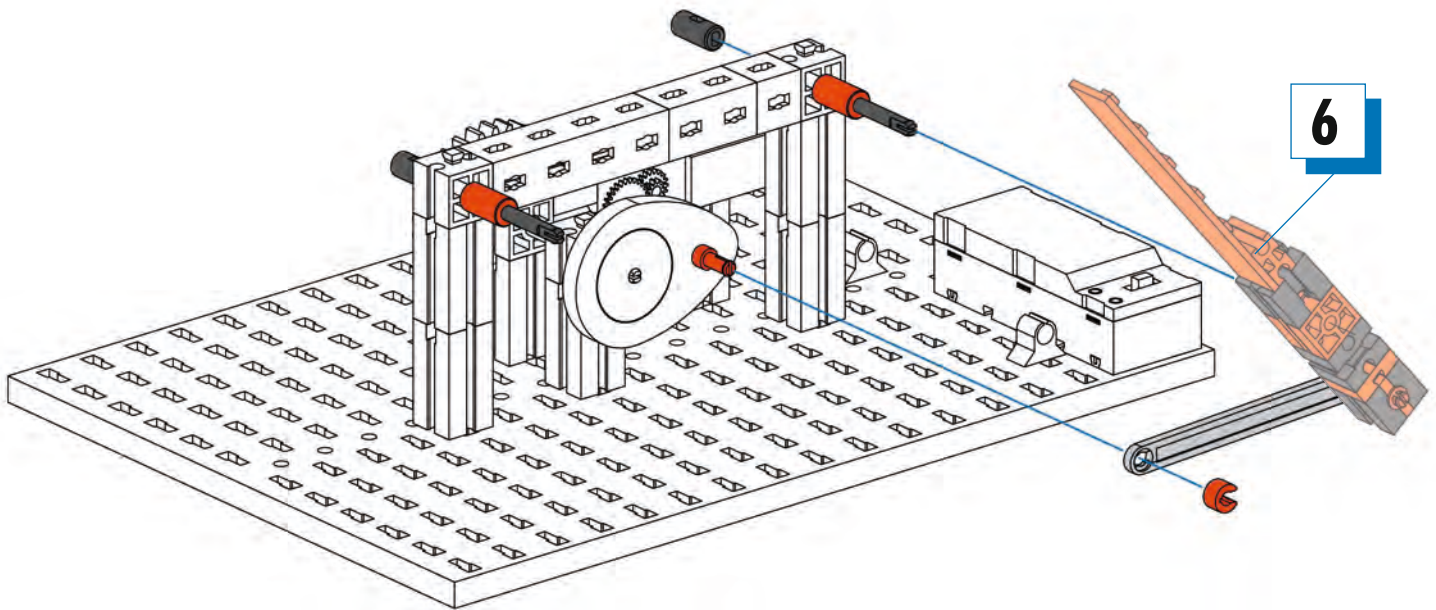
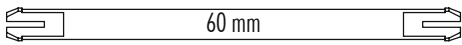

- 2x [Black 60mm Technic Pin]
- 2x [Black Technic Pin]
- 2x [Red Technic Pin]
- 1x [Red 1x2 Technic Brick]
- 1x [Red 1x3 Technic Brick]
- 1x [Red 1x5 Technic Beam]
- 1x [Grey 75mm Technic Pin]

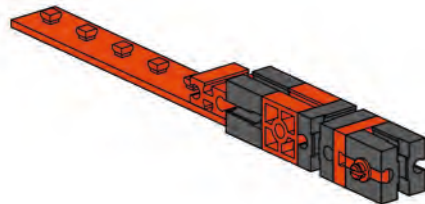

**8**

- 3x [Grey 1x3 Technic Brick]
- 1x [Red 1x3 Technic Brick]
- 1x [Red 1x2 Technic Brick]
- 1x [Red 1x5 Technic Beam]
- 1x [Red Technic Pin]

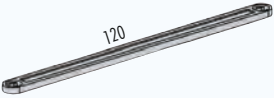

**9**  2 x  1 x  2 x

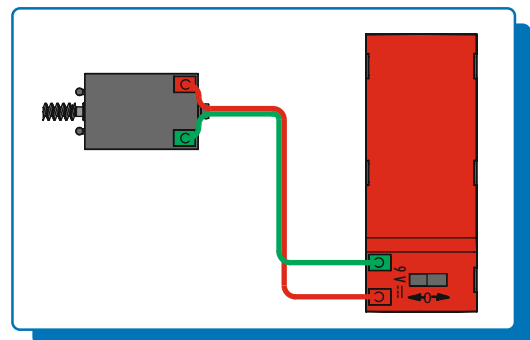
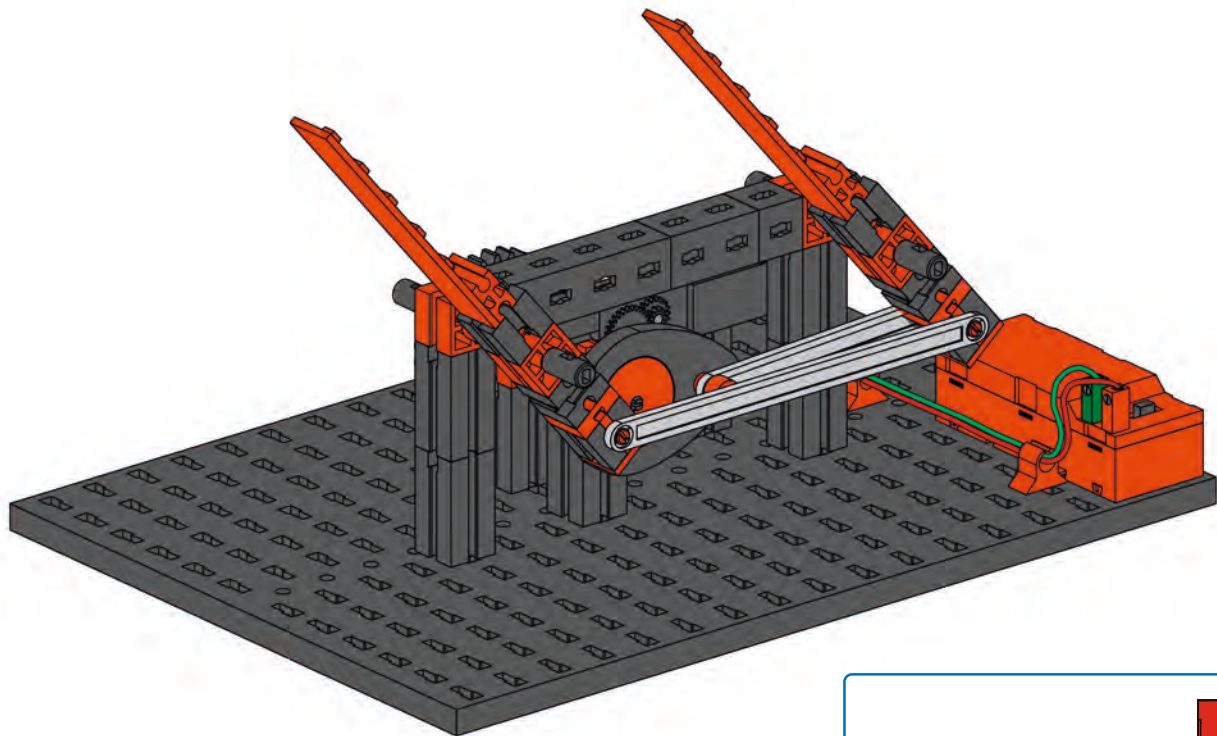
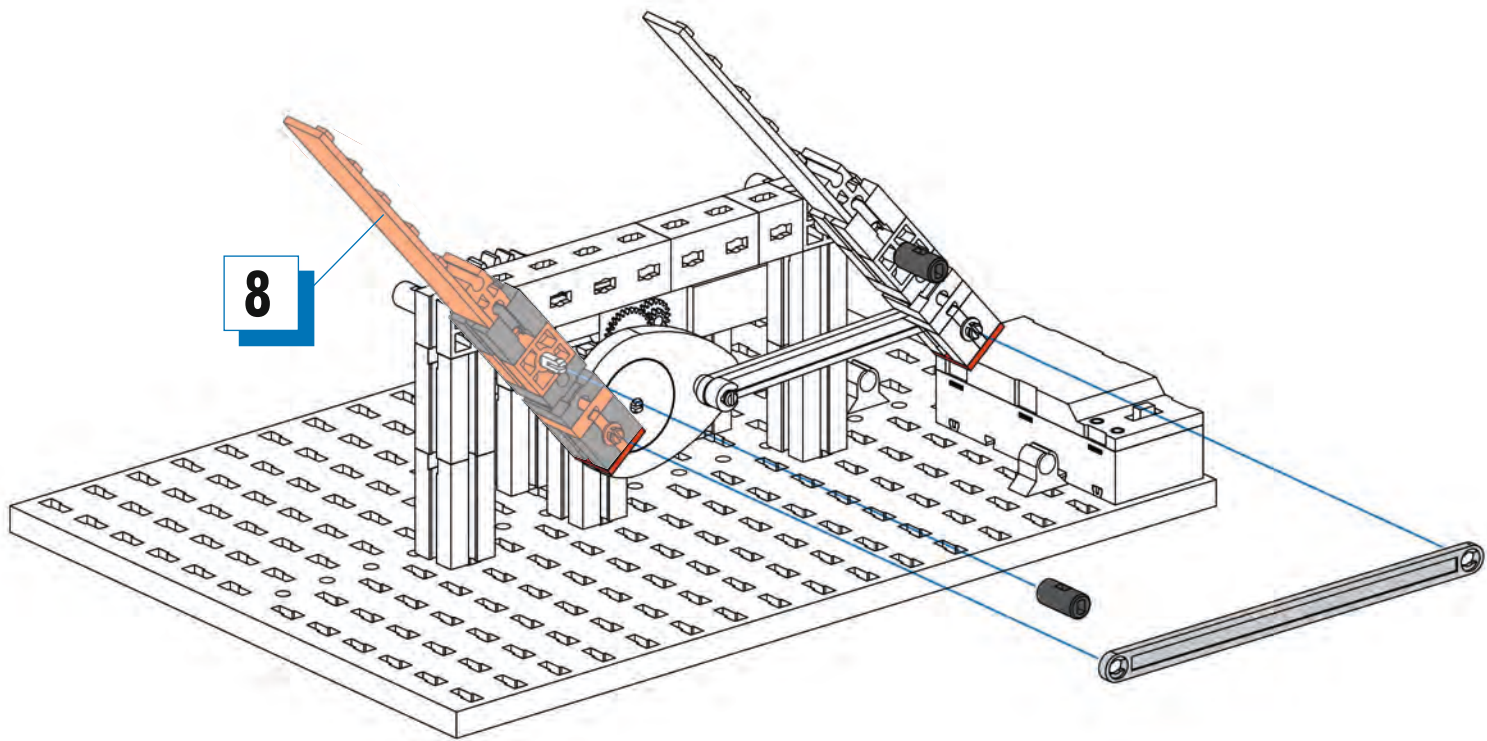



**Viergelenkkette**  
**Four-bar chain**  
**Chaîne cinématique à quatre joints articulés**

**Vierscharniersmechanisme**  
**Mecanismo de cuatro articulaciones**  
**Corrente de quatro articulações**

**Catena a quattro articolazioni**  
**Четырехзвенный шарнирный механизм**  
**四活节链**

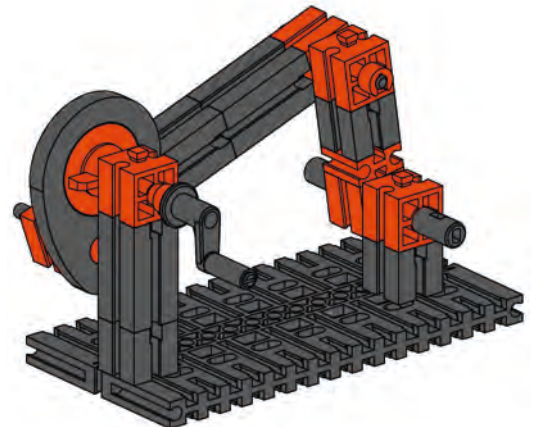
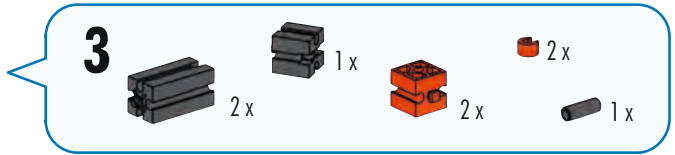
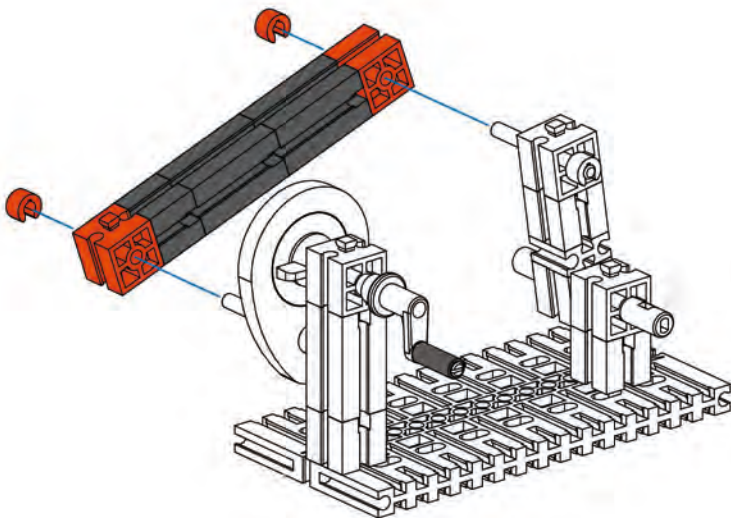
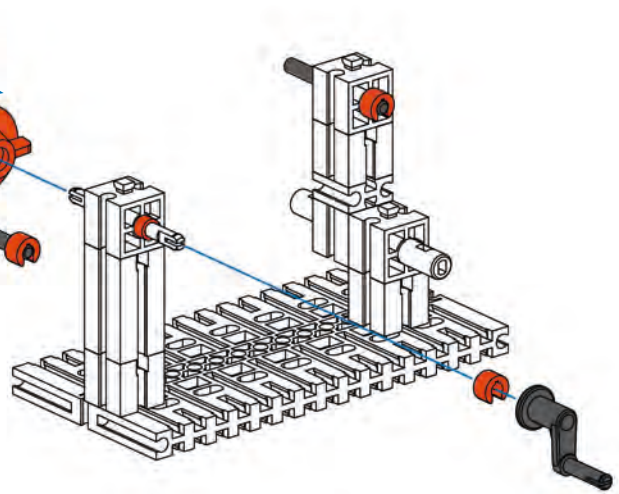
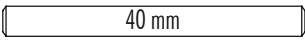
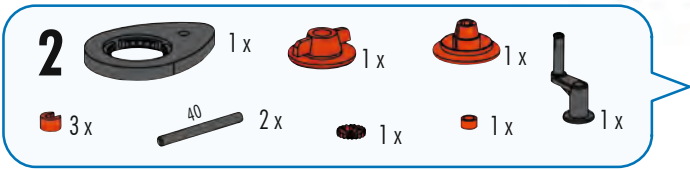
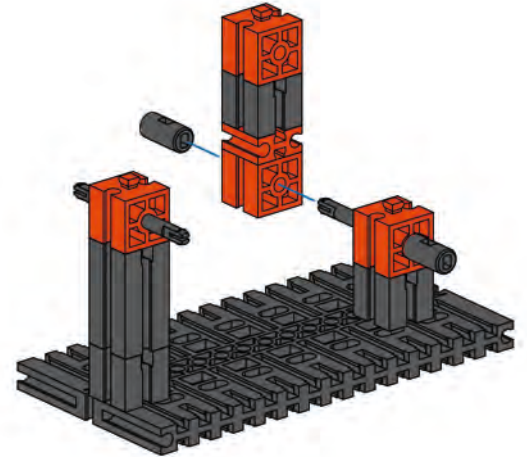
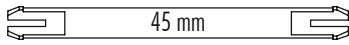
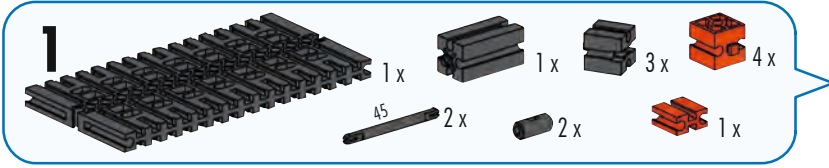

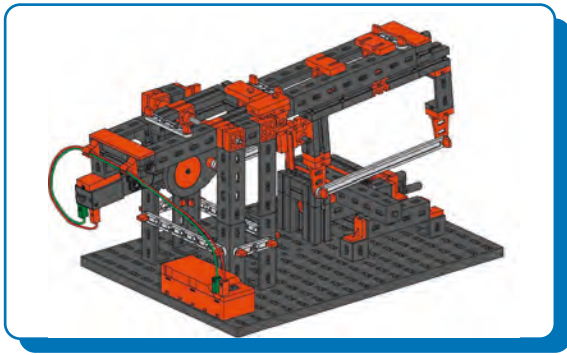

**Bügelsäge**  
**Power hacksaw machine**  
**Scie à archet**



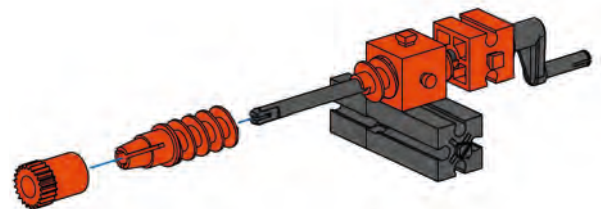
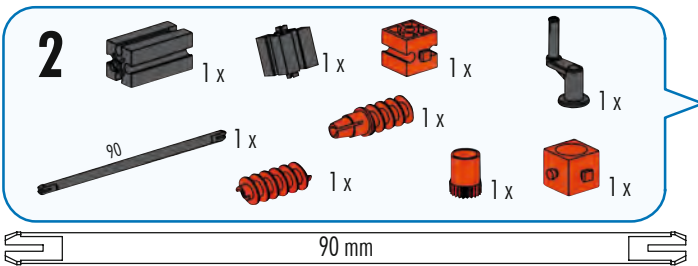
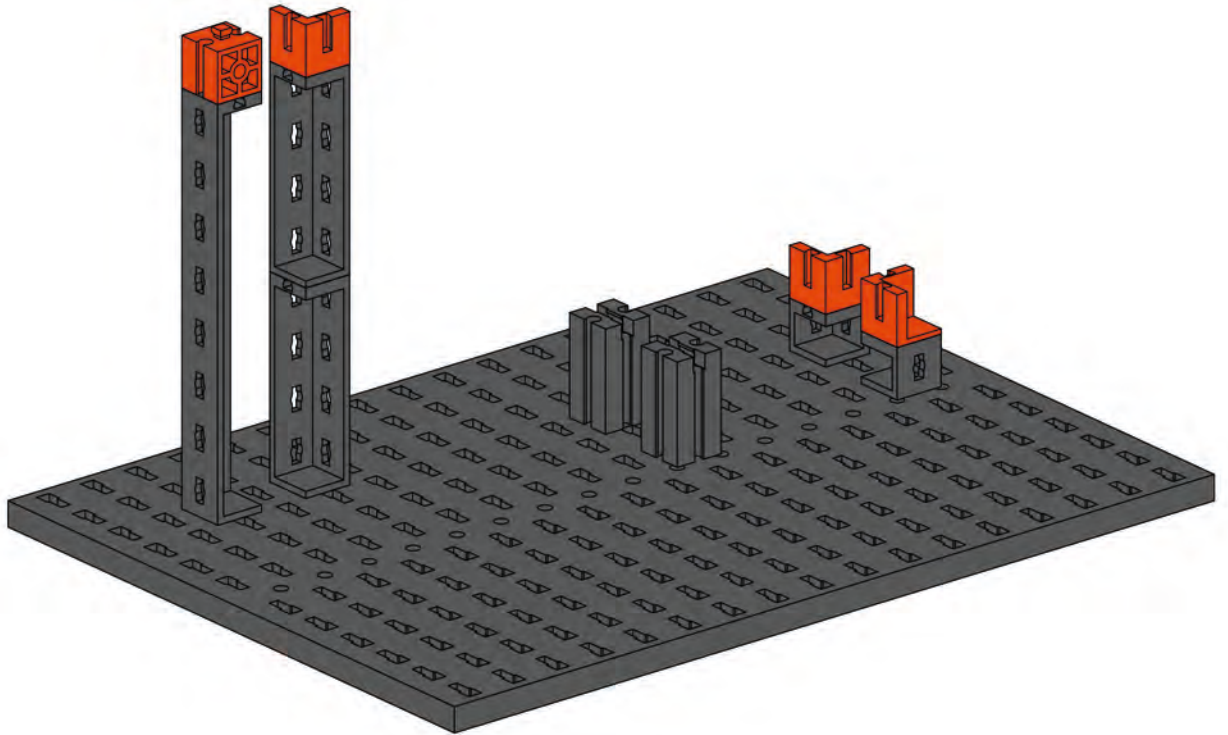
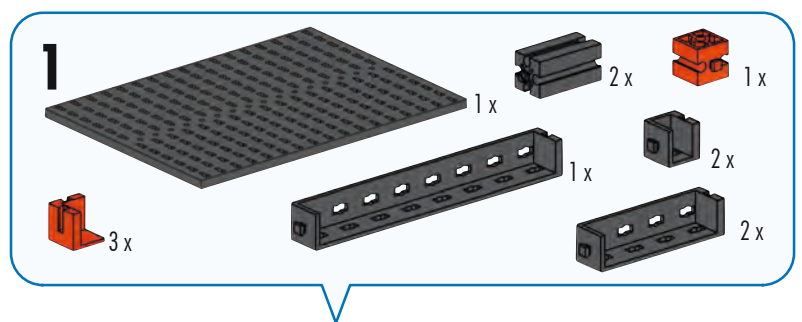

**Beugelzaag**  
**Sierra de arco**  
**Serra de arco**

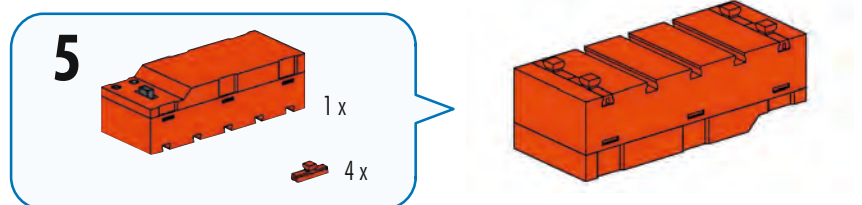
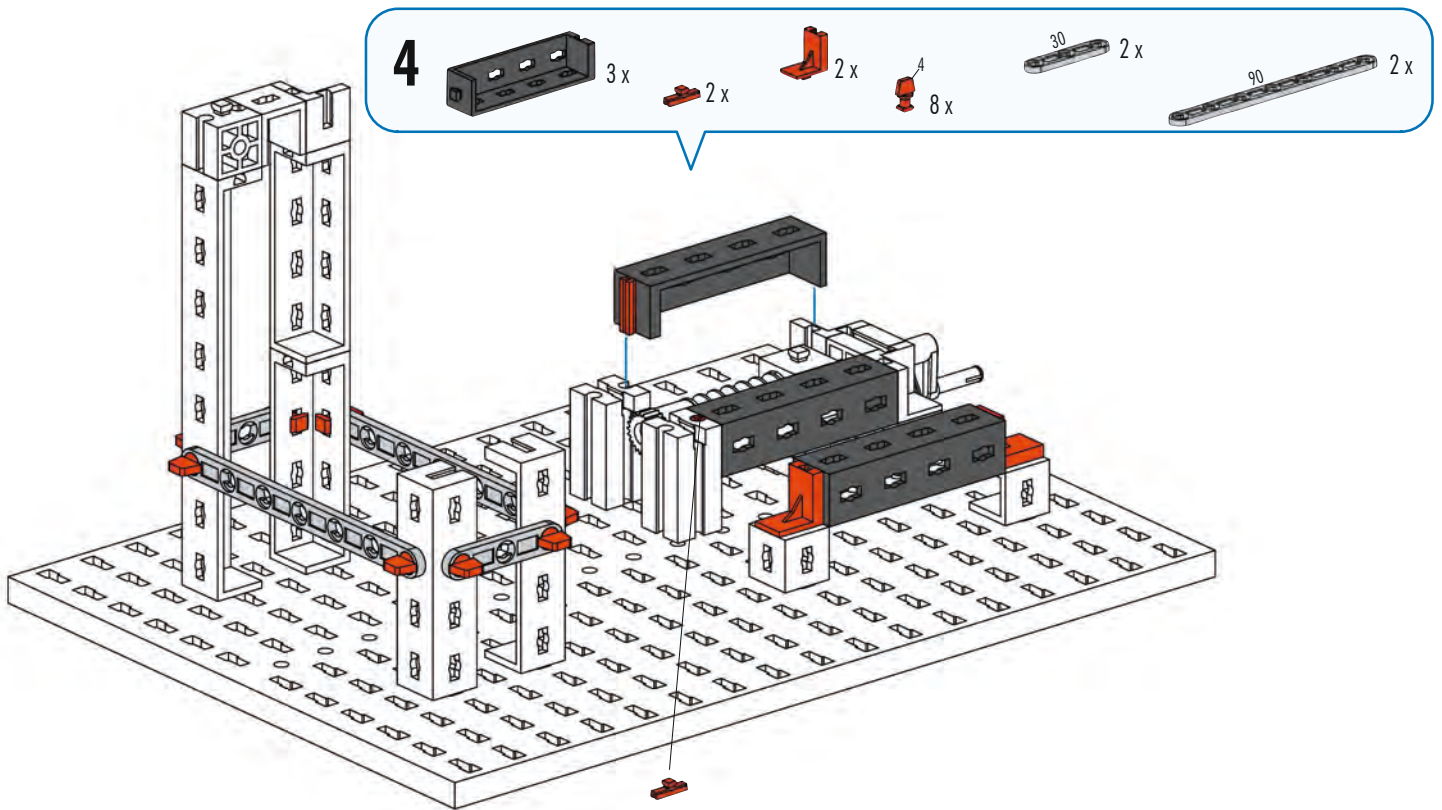
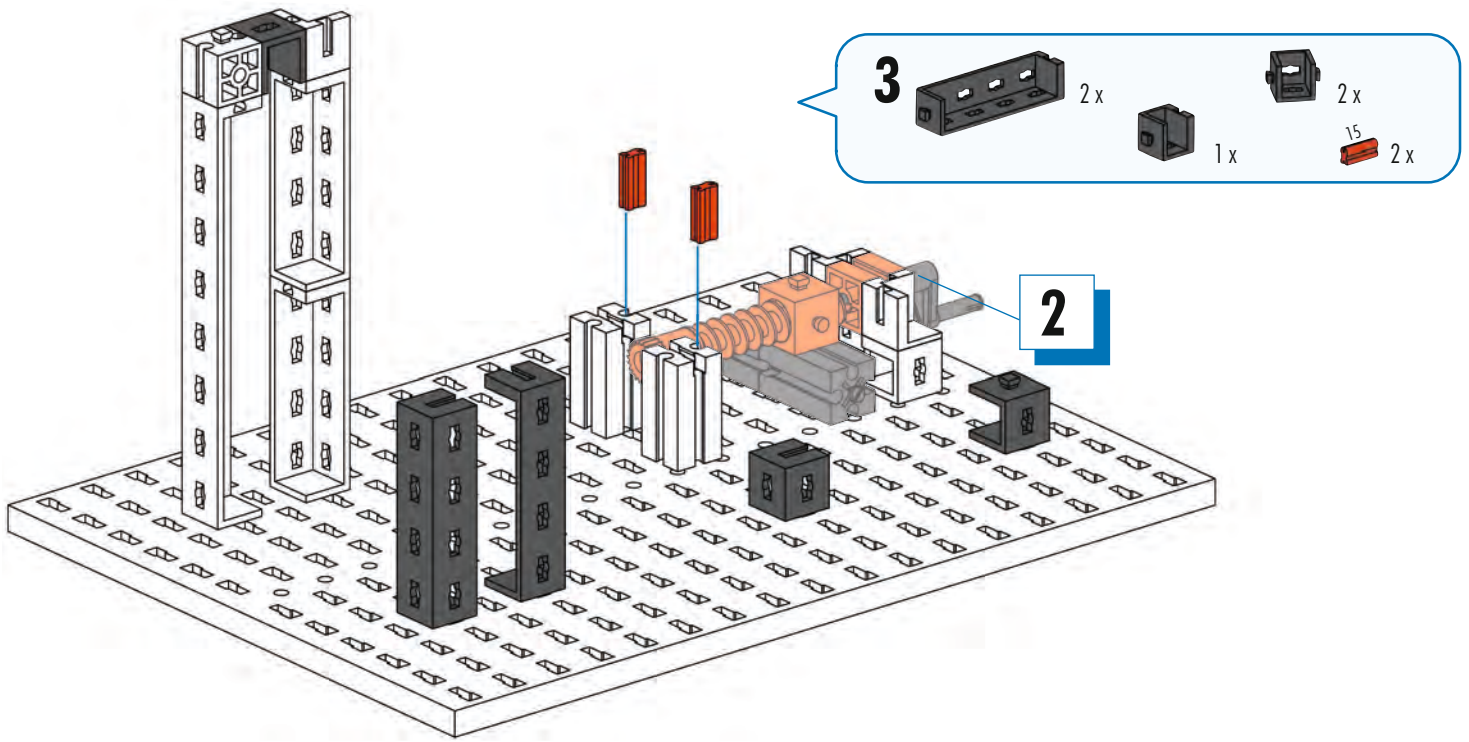
**Seghetto ad arco**  
**Ножовка**  
**弓锯**









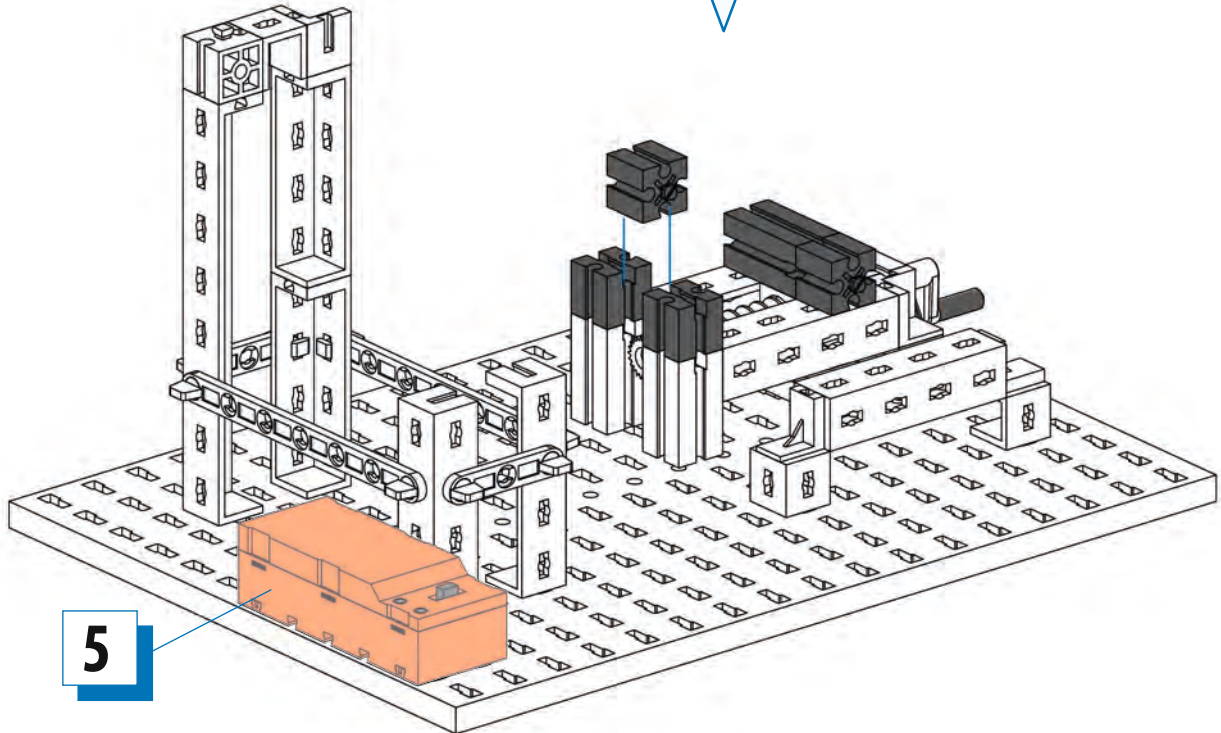





- 6**  1x  2x  2x  1x









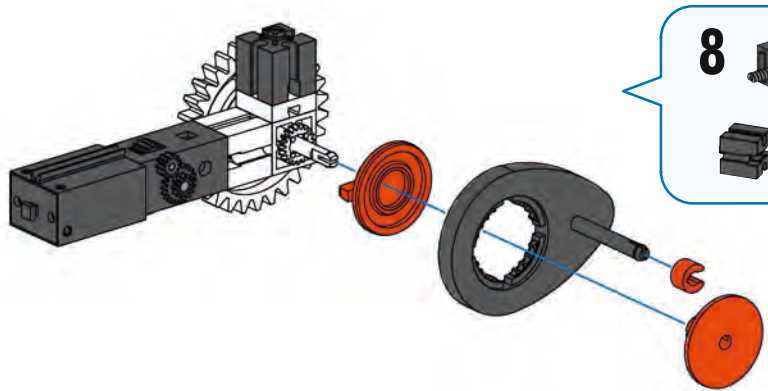
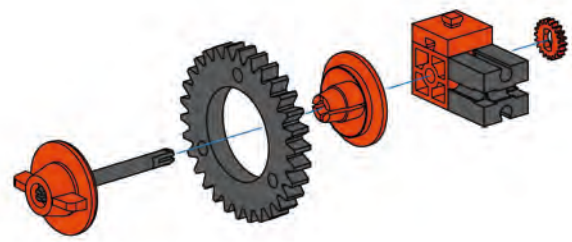

**5**

- 7**  1x  1x  1x  1x  1x  1x  1x  1x

45 mm



- 8**  1x  1x  1x  1x  1x  1x  1x  1x

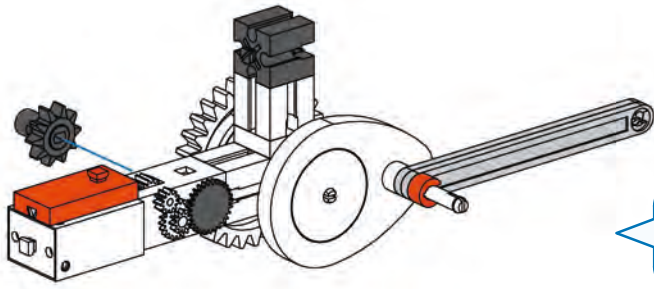

**9**

- 1x [Black 1x2 Technic Brick]
- 1x [Red 1x2 Technic Brick]
- 1x [Black Technic Pin]
- 1x [Black Technic Pin]
- 1x [Red Technic Pin]
- 2x [Black Technic Axle, length 75]

**10**

- 2x [Black 1x2 Technic Brick]
- 1x [Black 1x2 Technic Brick]
- 1x [Black 1x2 Technic Brick]
- 2x [Red 1x2 Technic Brick]
- 1x [Black 1x4 Technic Beam]
- 2x [Black 1x2 Technic Brick]
- 1x [Black 1x2 Technic Brick]

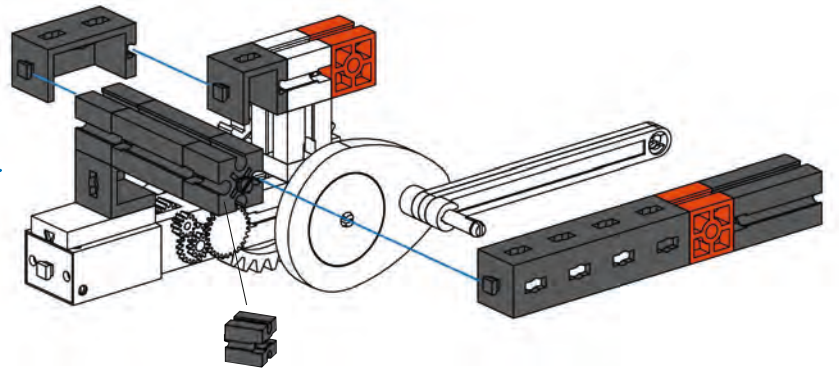

**11**

- 5x [Black 1x2 Technic Brick]
- 1x [Black 1x2 Technic Brick]
- 2x [Red 1x2 Technic Brick]
- 6x [Red 1x2 Technic Brick]
- 1x [Red 1x2 Technic Brick]
- 2x [Red 1x2 Technic Brick]
- 1x [Red 1x2 Technic Brick]
- 2x [Red Technic Pin]

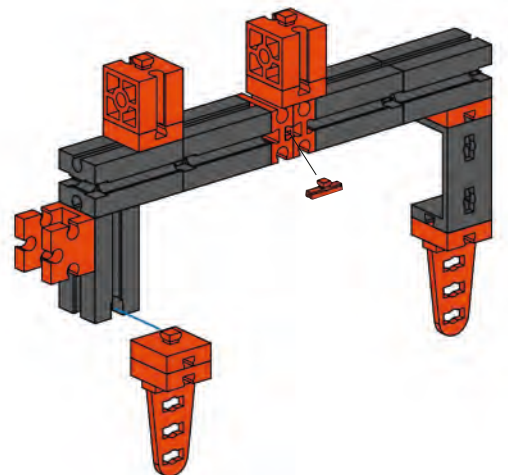

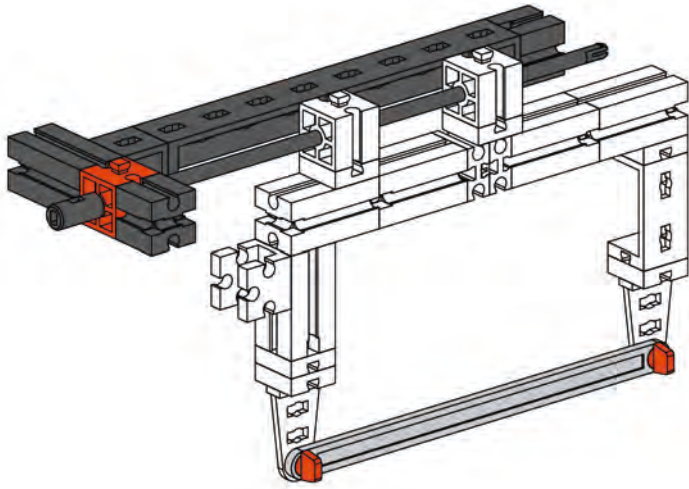

**12**

- 1x 120
- 1x 180
- 1x
- 1x
- 1x
- 1x
- 1x
- 2x
- 1x
- 2x

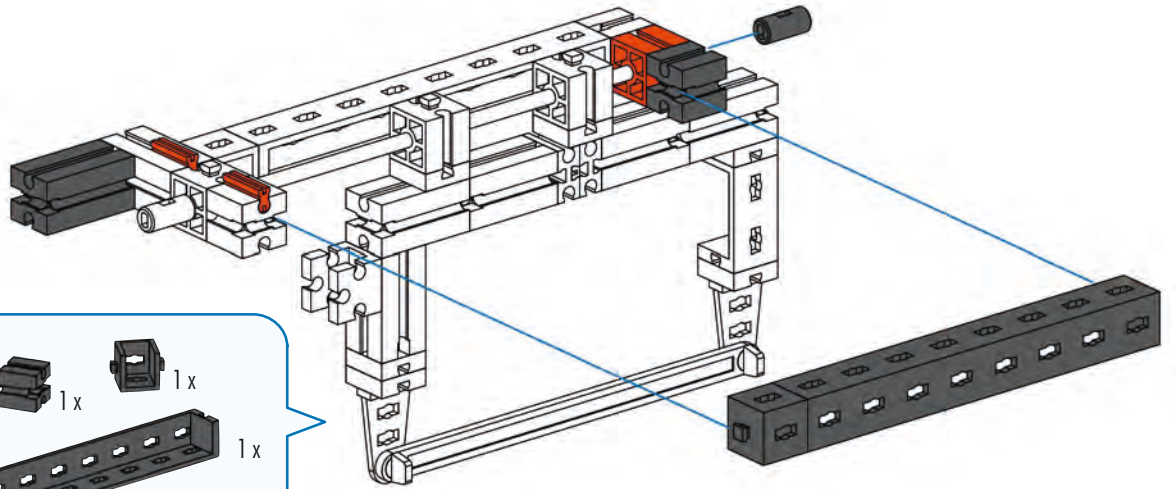

**13**

- 1x
- 1x
- 1x
- 1x
- 1x
- 1x
- 15
- 2x

**14**

- 30
- 2x
- A
- 4x
- 1x
- 2x
- 40
- 1x

40 mm

**10**

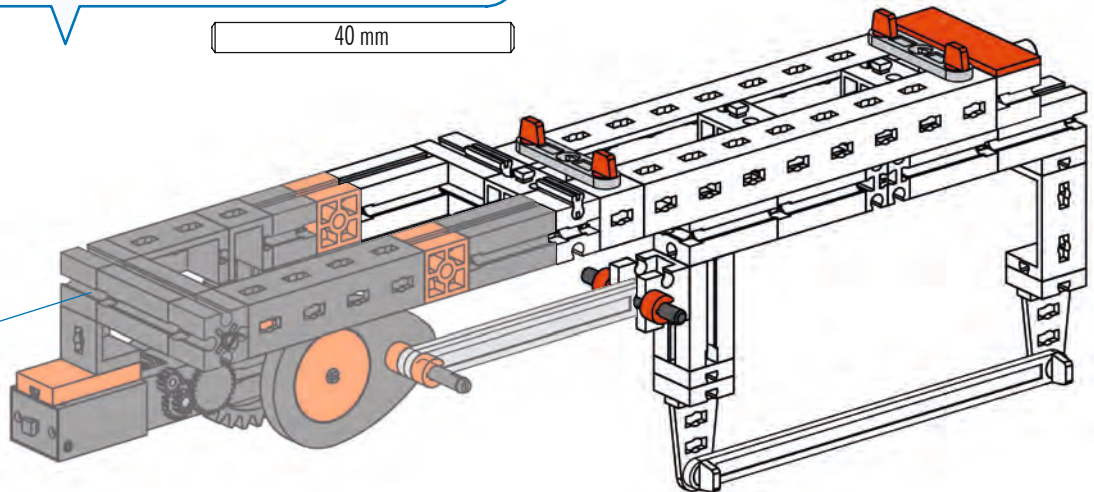

15

- 110 1x
- 1x
- 2x
- 2x

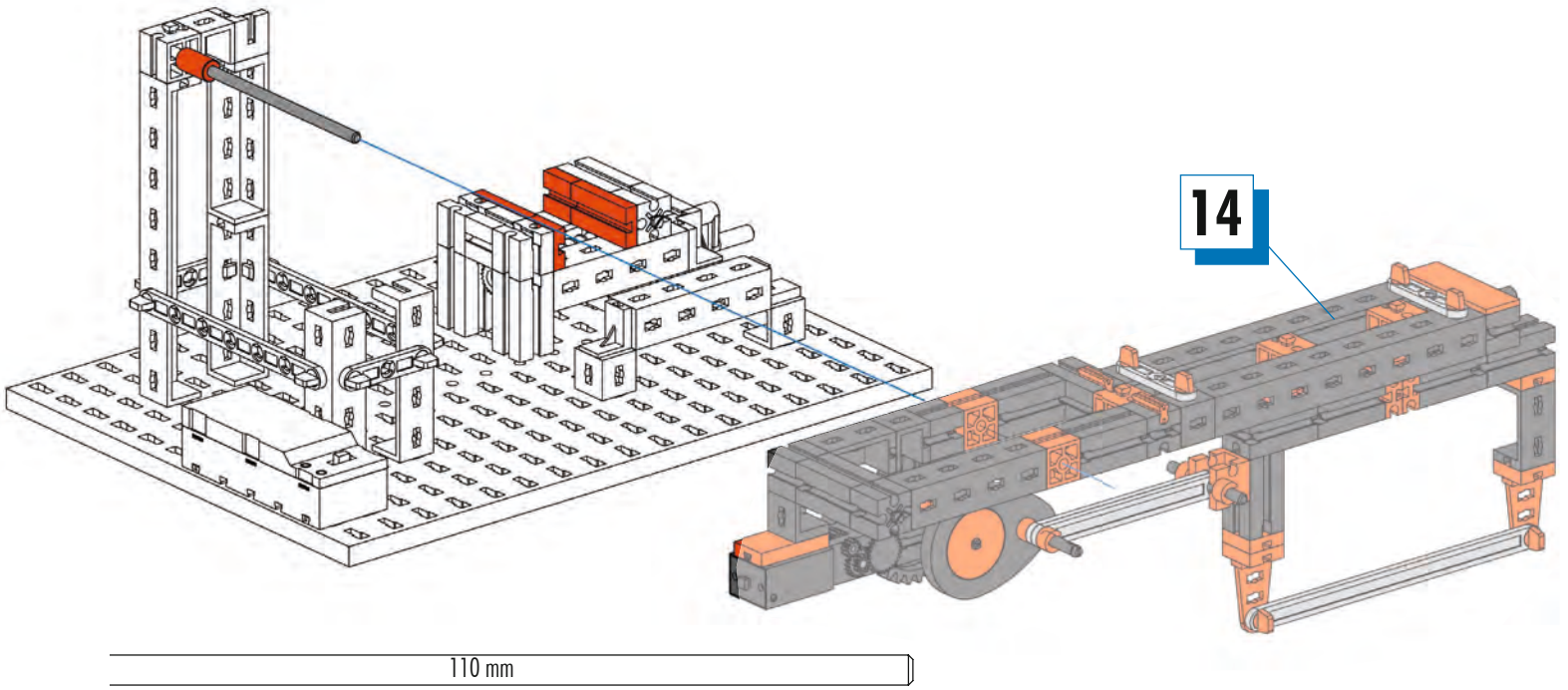

16

- 2x
- 1x
- 2x
- 3x
- 2x
- 2x
- 1x

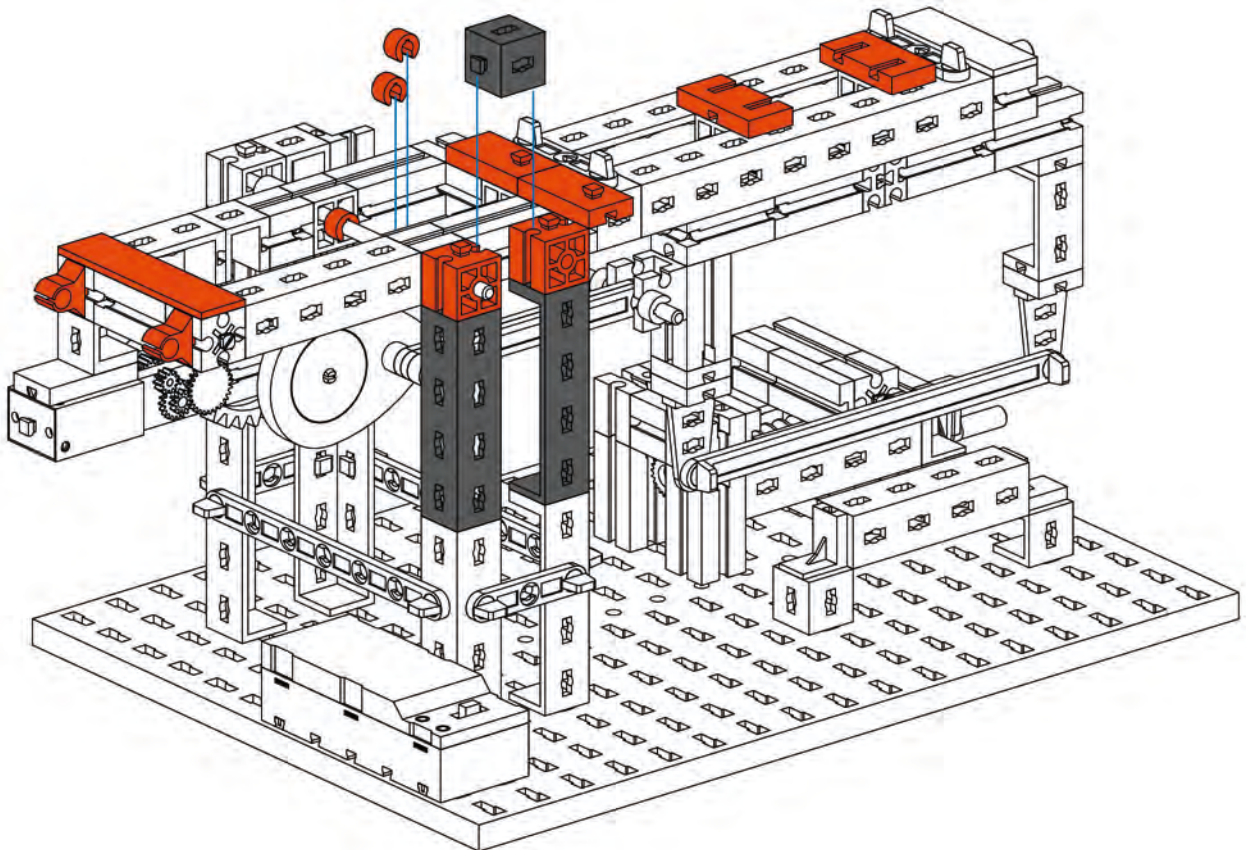

**17**

- 1 x
- 2 x
- 1 x
- 1 x
- 1 x
- 1 x
- 1 x
- 1 x

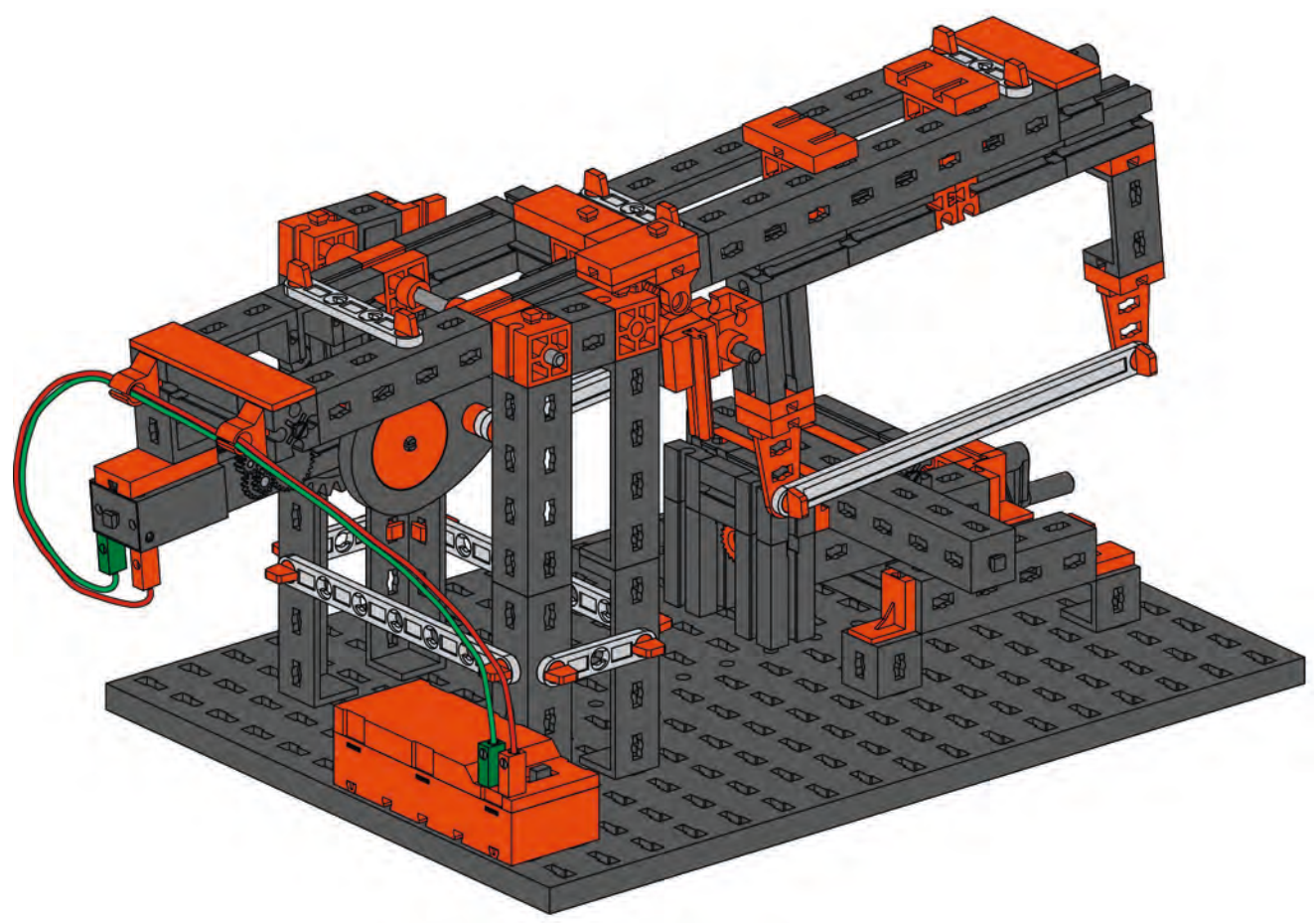
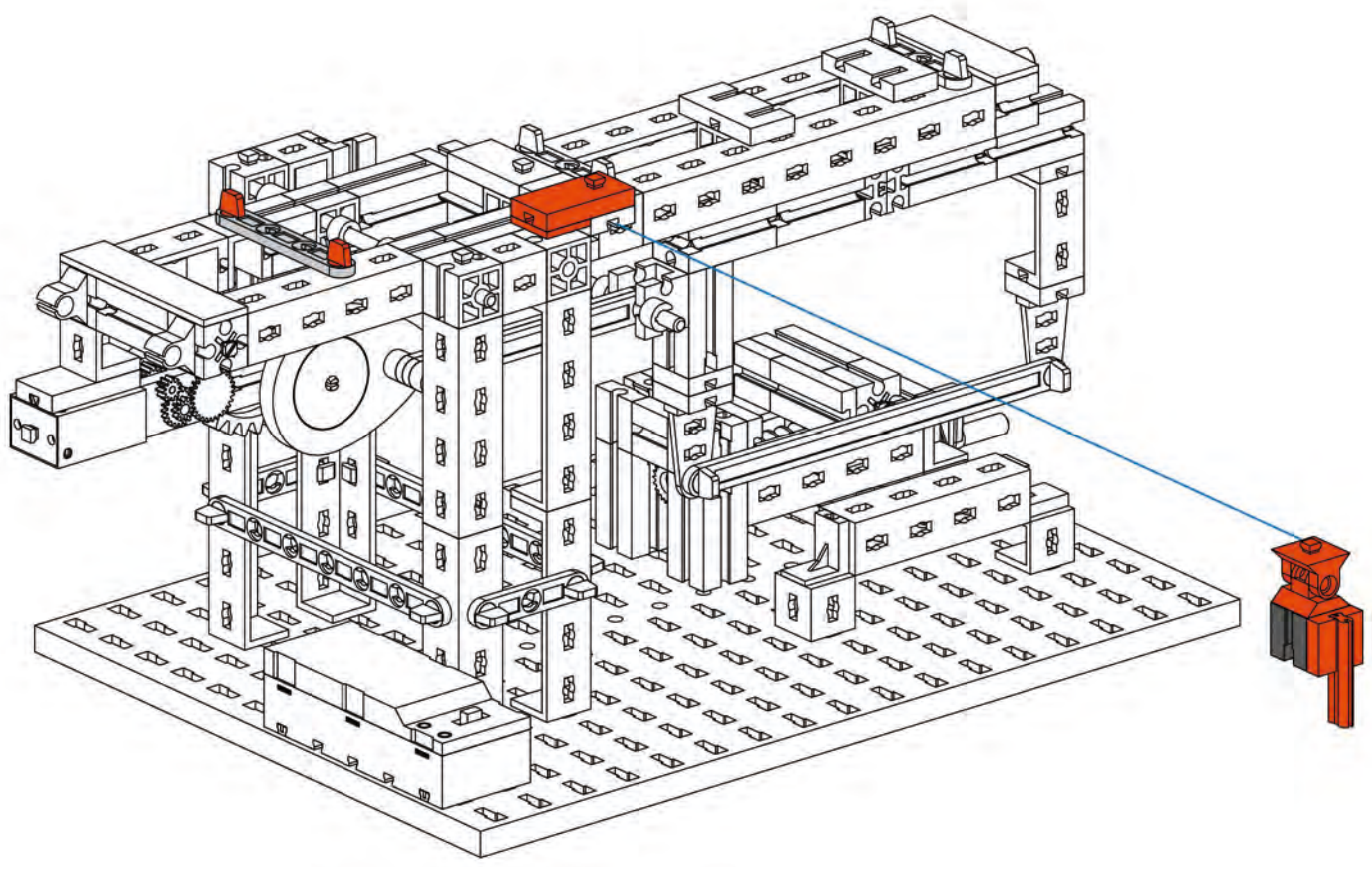

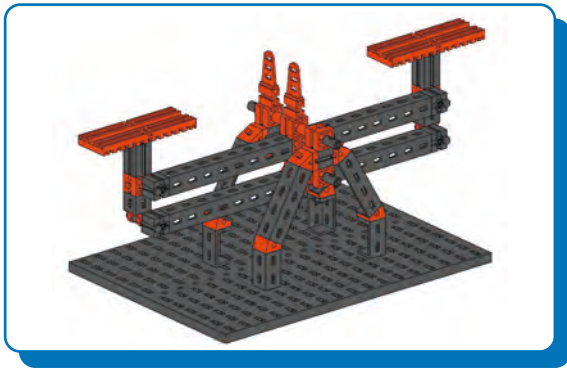

**Balkenwaage**  
**Beam and scales**  
**Crochet-bascule**

**Balansweegschaal**  
**Balanza de brazos**  
**Balança de pratos**

**Bilancia a braccio**  
**Весы с коромыслом**  
**天平**

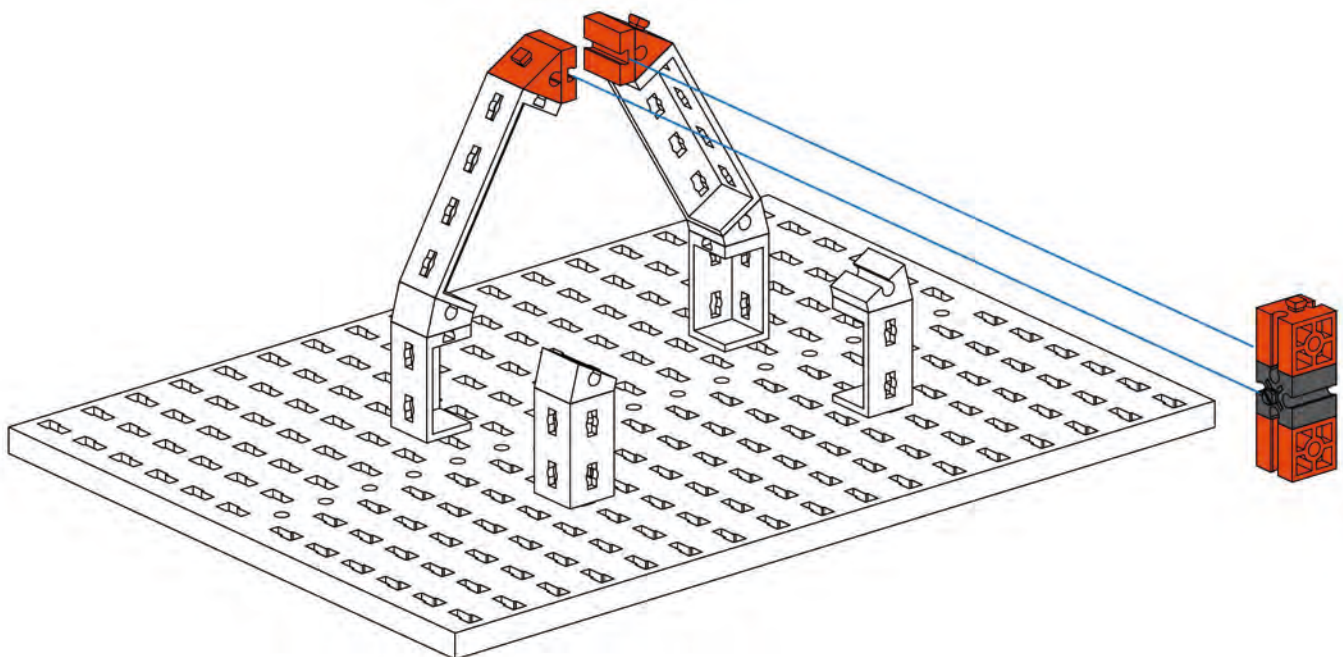
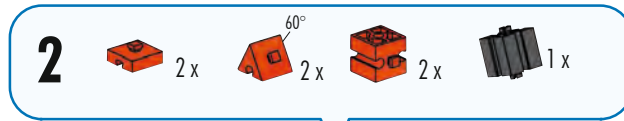
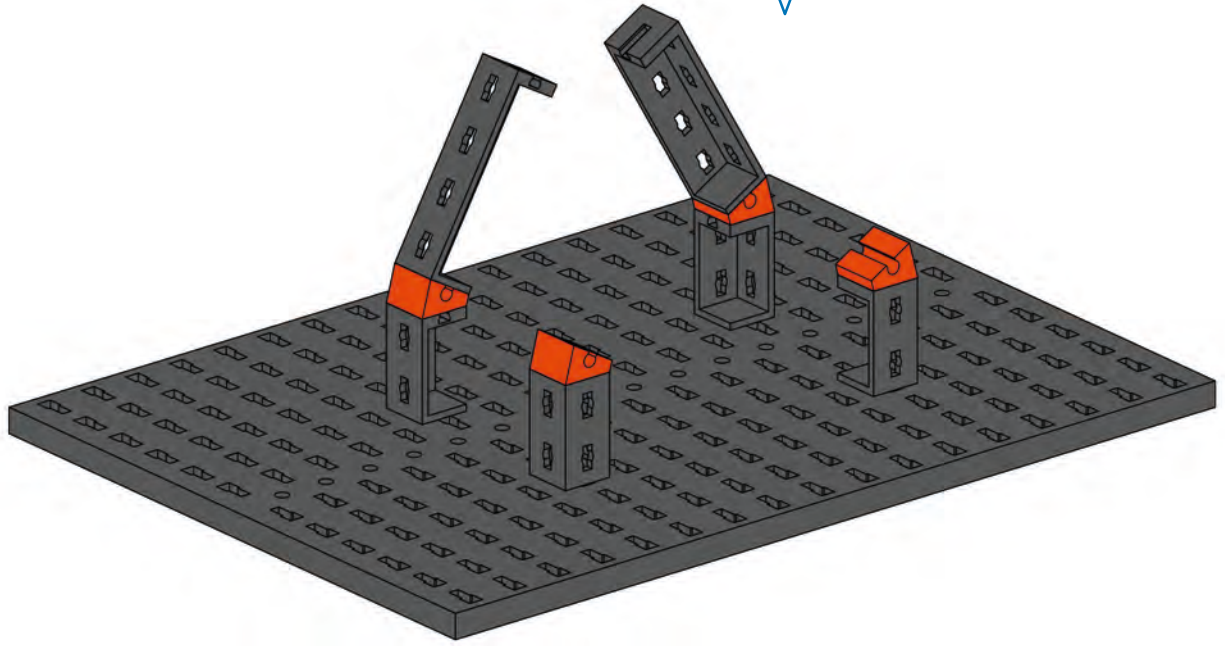
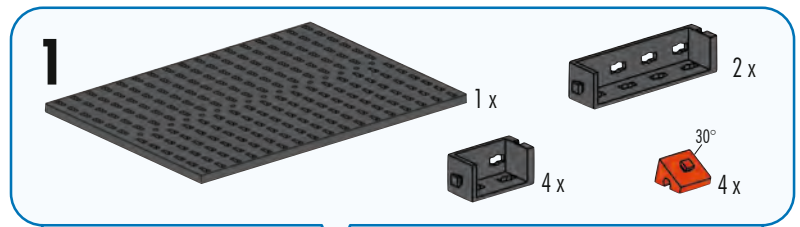

**3**

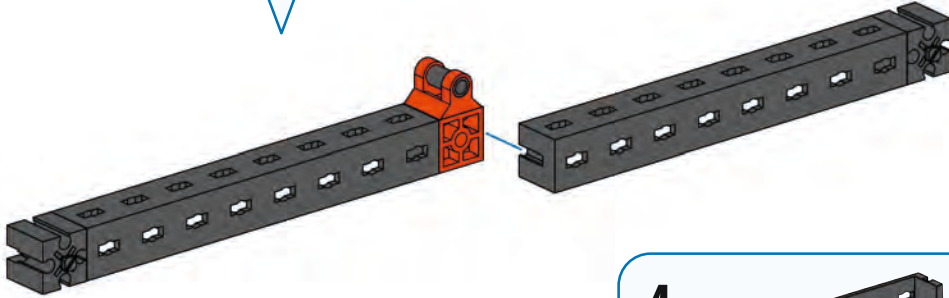
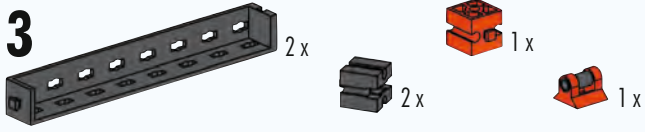

**4**

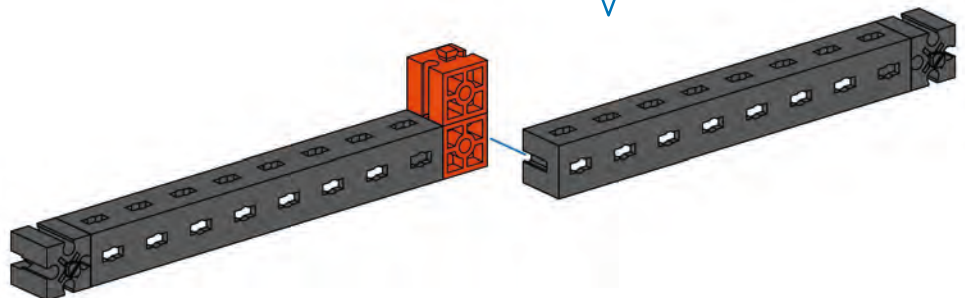
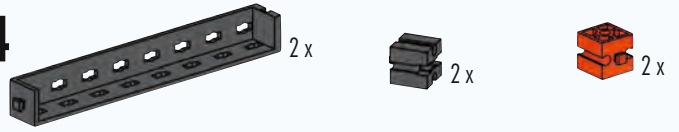

**5**

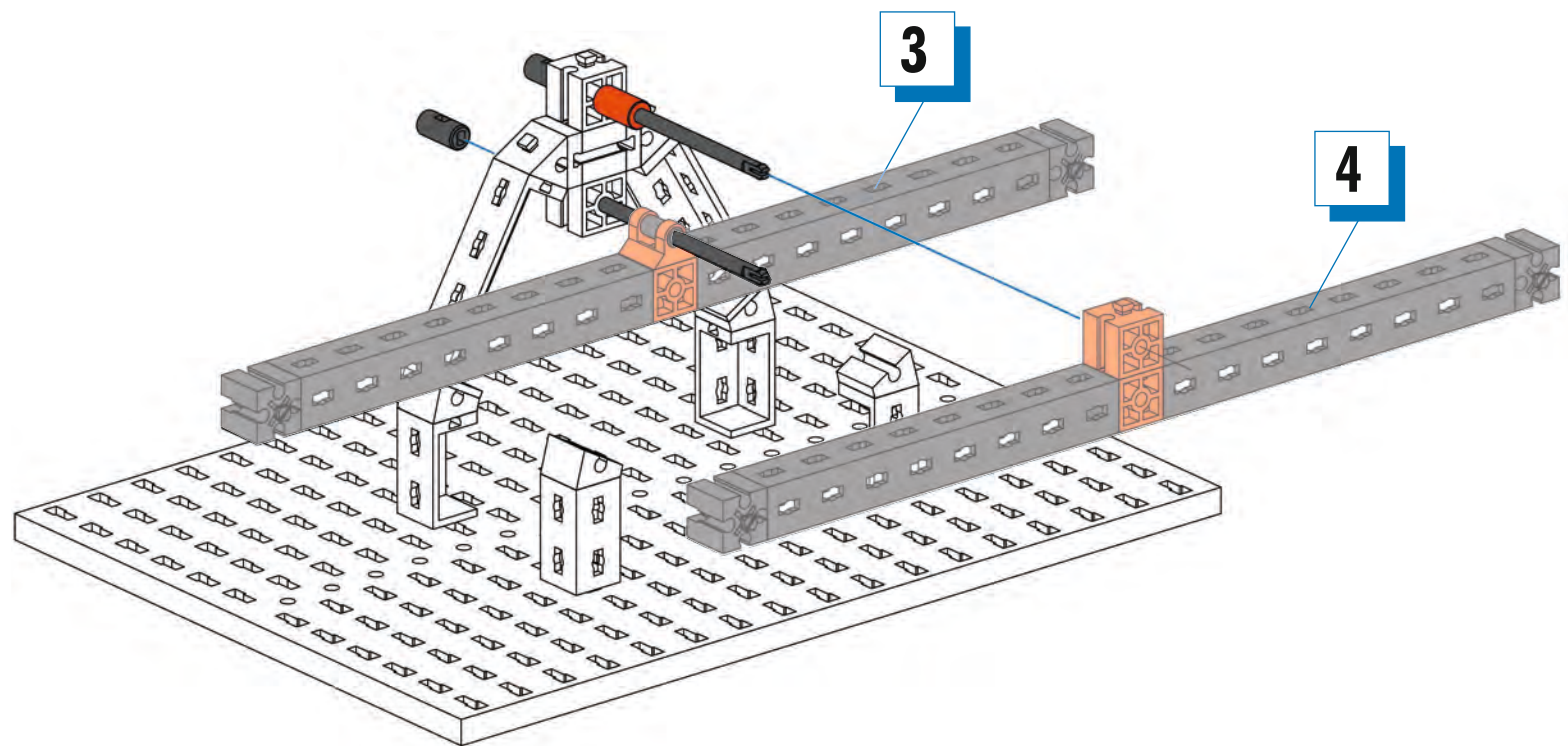
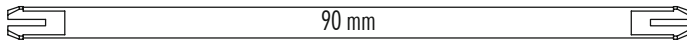

**6**

- 2 x [Grey Technic Beam 1x5]
- 2 x [Red Technic 60° Wedge]
- 2 x [Red Technic 1x2 Plate]
- 2 x [Red Technic 1x2 Plate with Hole]
- 1 x [Grey Technic 1x2 Plate]
- 1 x [Red Technic Pin]

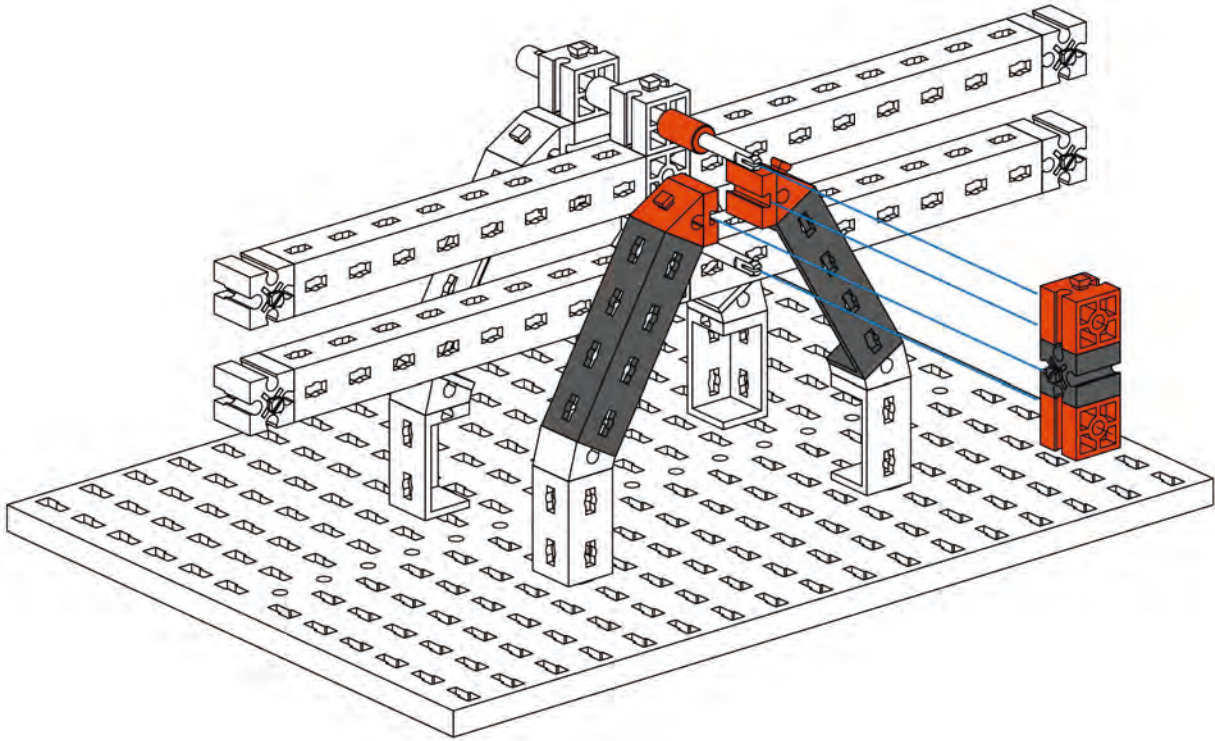



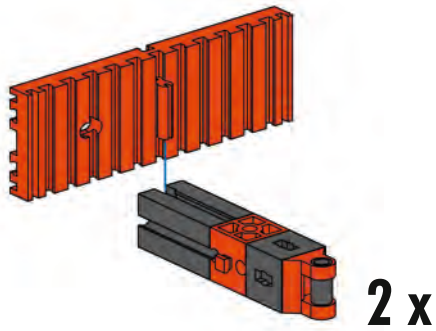

**7**

- 2 x [Red Technic 1x15 Technic Beam]
- 2 x [Red Technic 1x2 Plate]
- 2 x [Red Technic 1x2 Plate with Hole]
- 2 x [Grey Technic 1x2 Plate]
- 2 x [Grey Technic 1x2 Plate]





- 8**  4x  2x  2x  2x

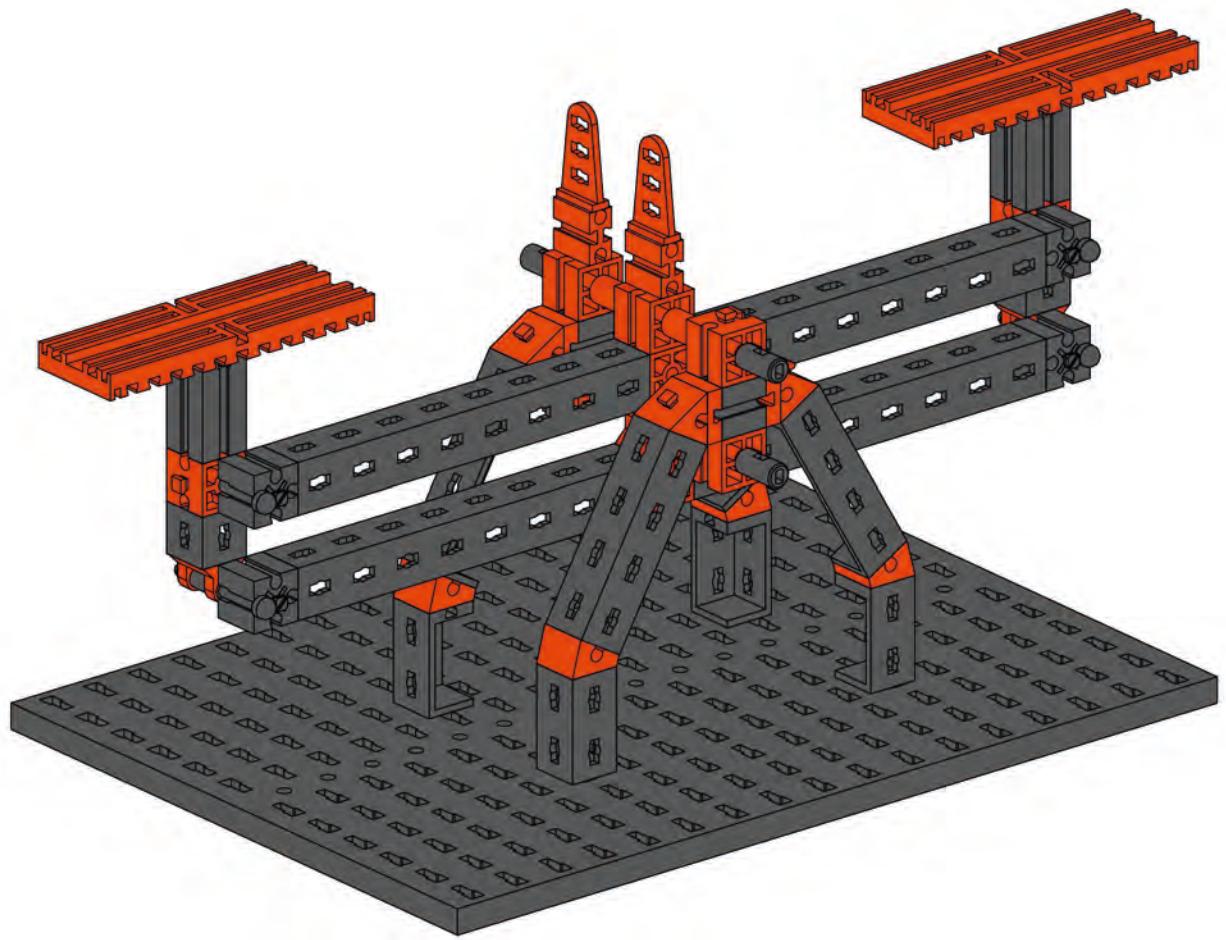
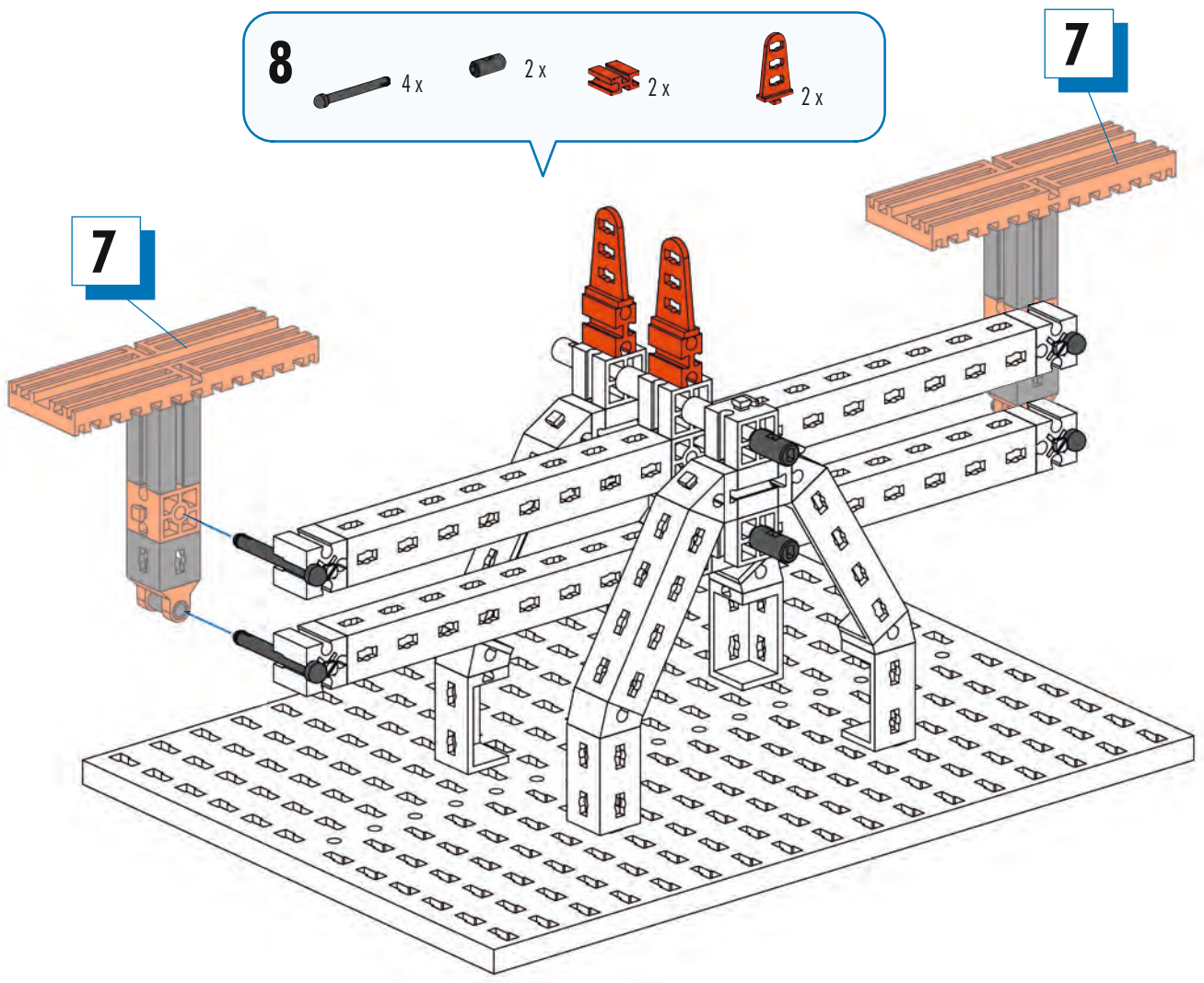

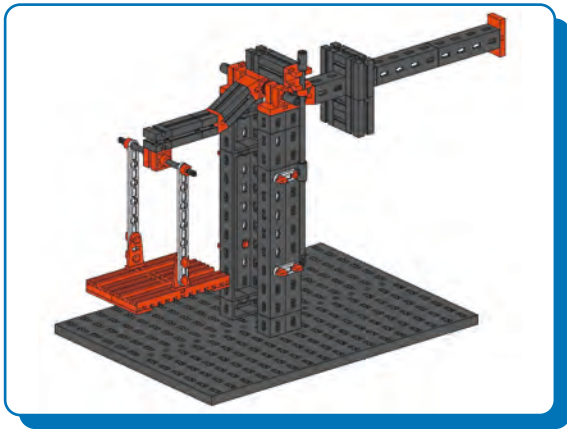

**Waage mit Laufgewicht**  
**Scales with sliding weight**  
**Balance à poids mobile**

**Weegschaal met schuifgewicht**  
**Balanza con pesa corrediza**  
**Balança com peso cursor**

**Bilancia con cursore**  
**Весы с подвижным грузом**  
**带滑动秤锤的天平**

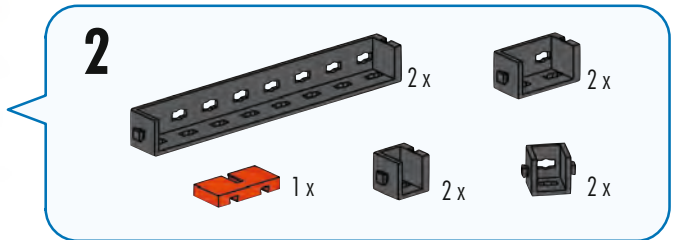
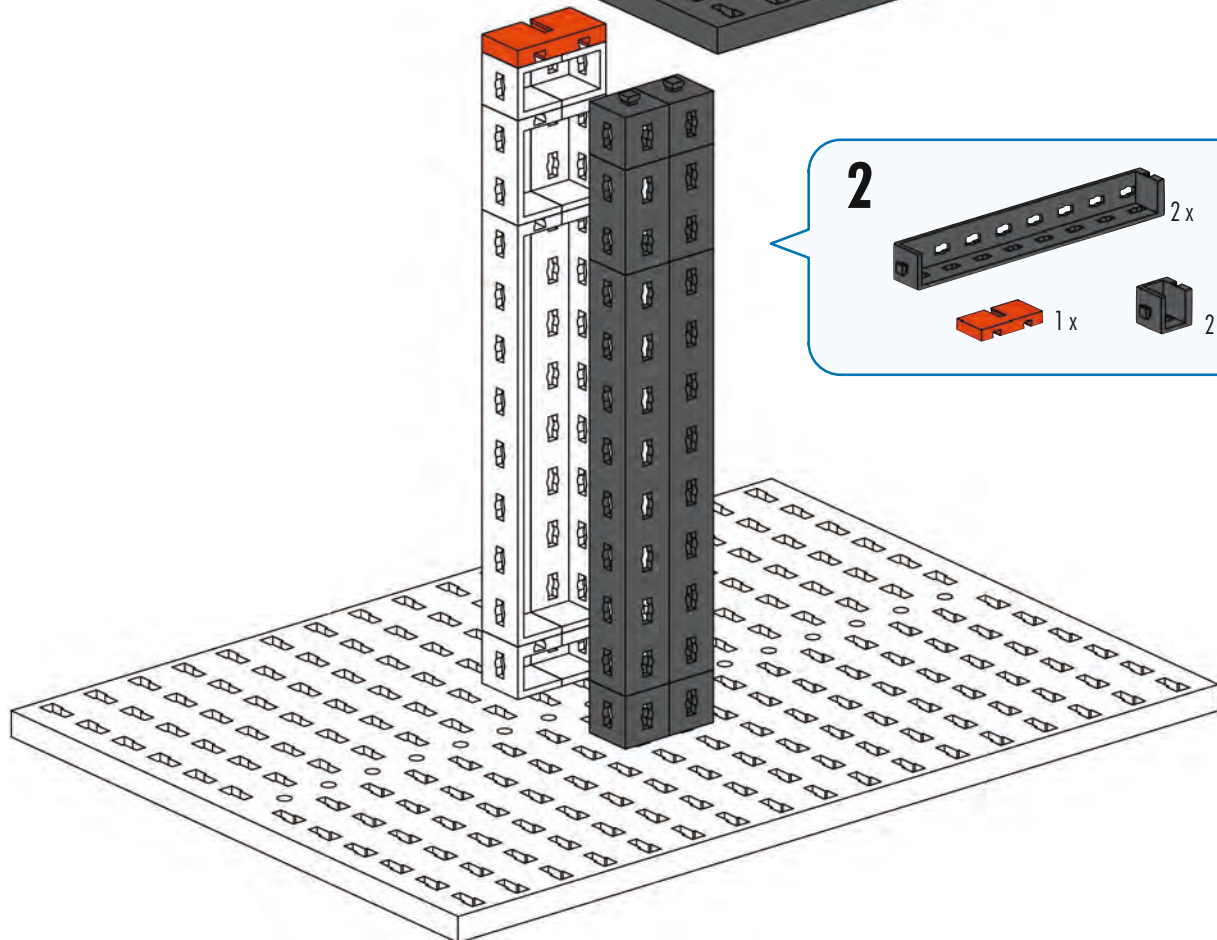
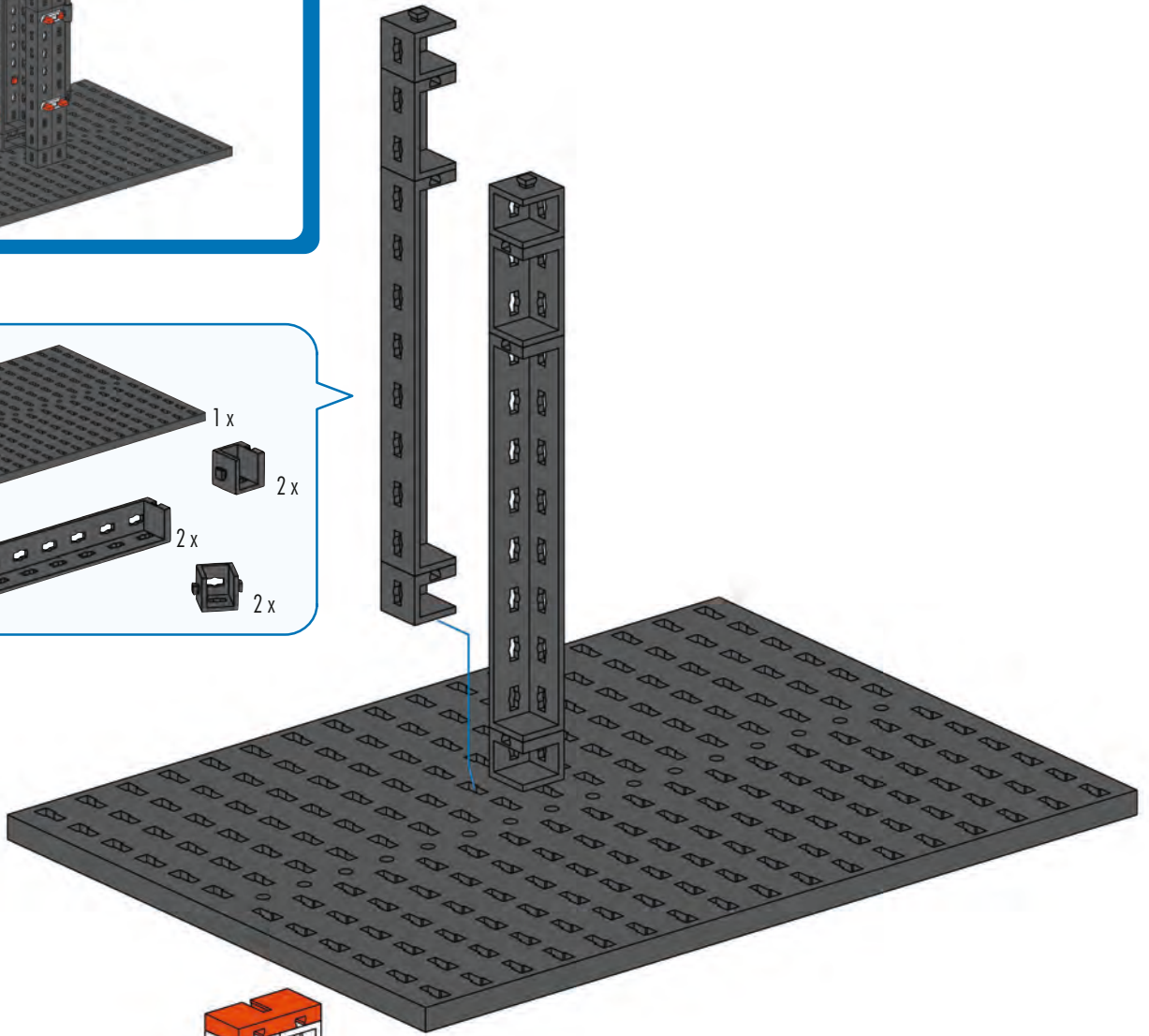
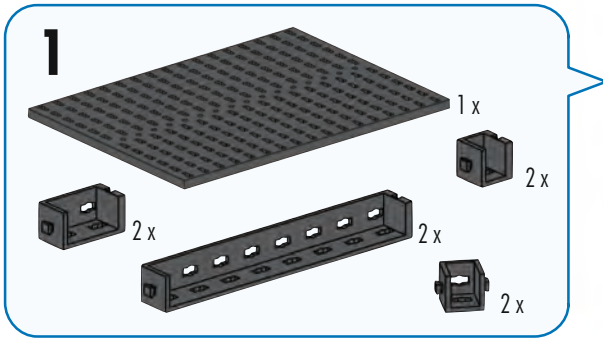

- 3**
- 1x [Orange 1x3 Technic Brick]
  - 1x [Orange 1x3 Technic Brick with Hole]
  - 4x [Grey Technic Pin]
  - 8x [Red Technic Pin]

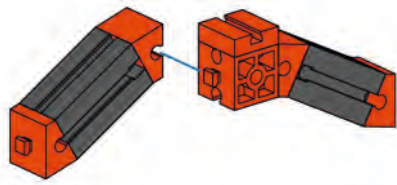
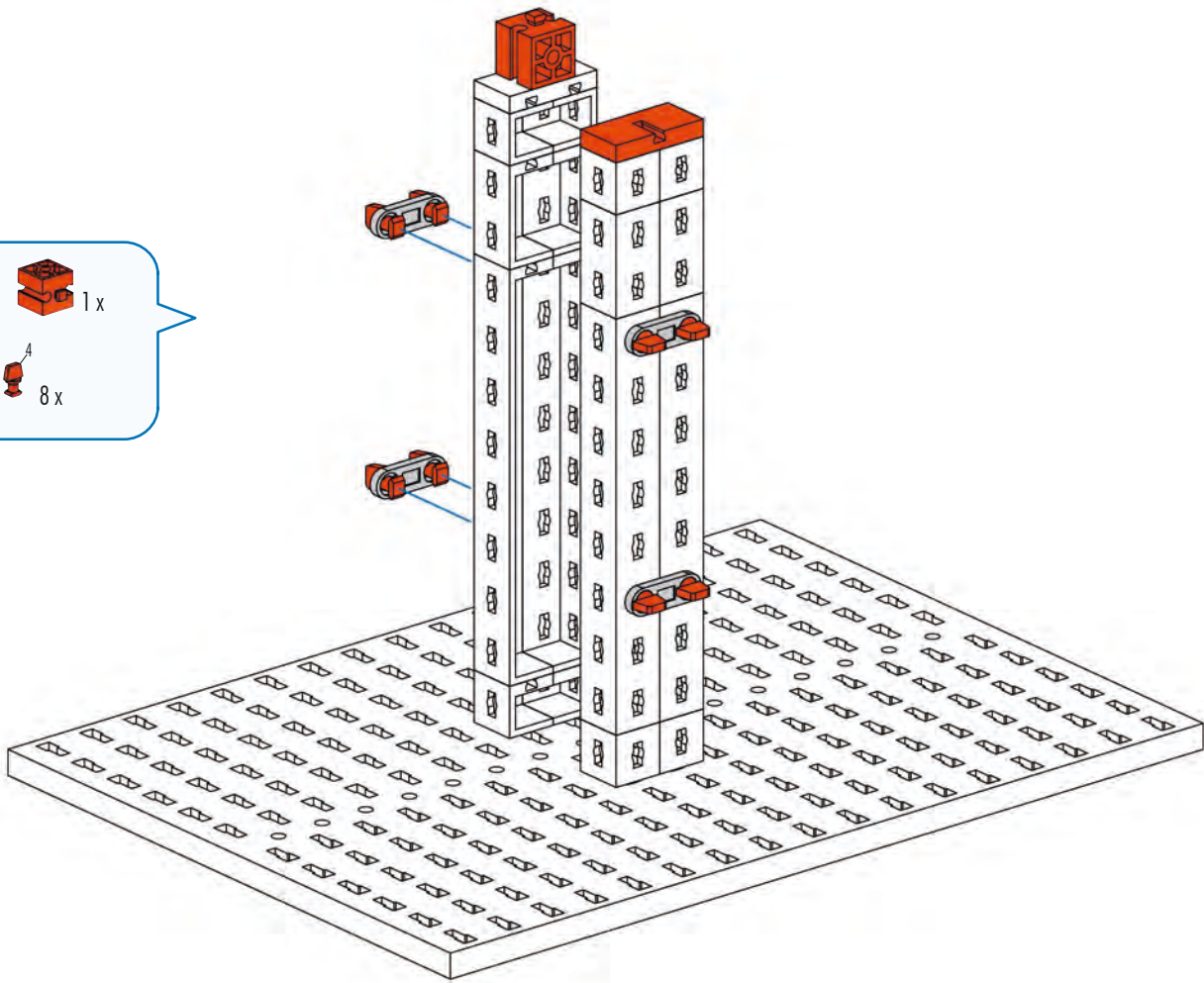

- 4**
- 2x [Grey Technic Pin]
  - 1x [Orange 1x3 Technic Brick with Hole]
  - 1x [Orange 1x3 Technic Brick]
  - 4x [Red Technic Pin, 30°]

- 5**
- 1x [Grey Technic Pin]
  - 2x [Grey Technic Pin]
  - 1x [Orange 1x3 Technic Brick with Hole]
  - 3x [Grey Technic Pin]

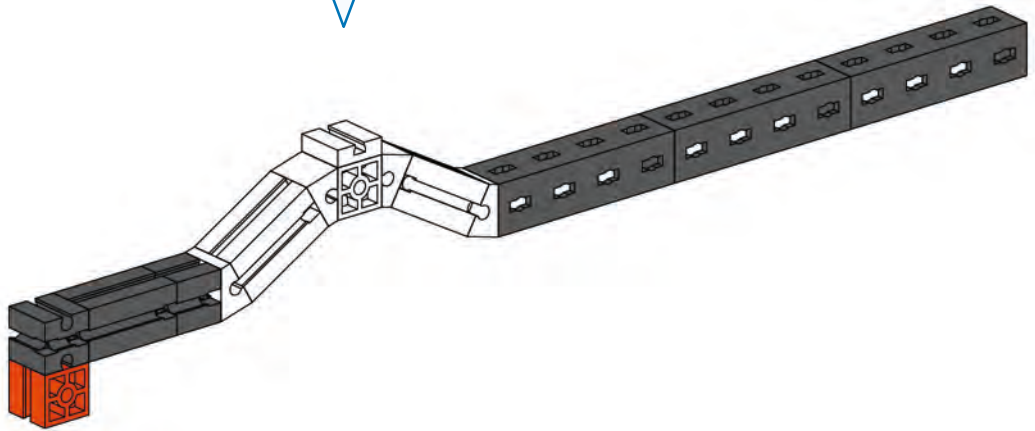

**6** 15 1x 3x 2x 1x

75 mm

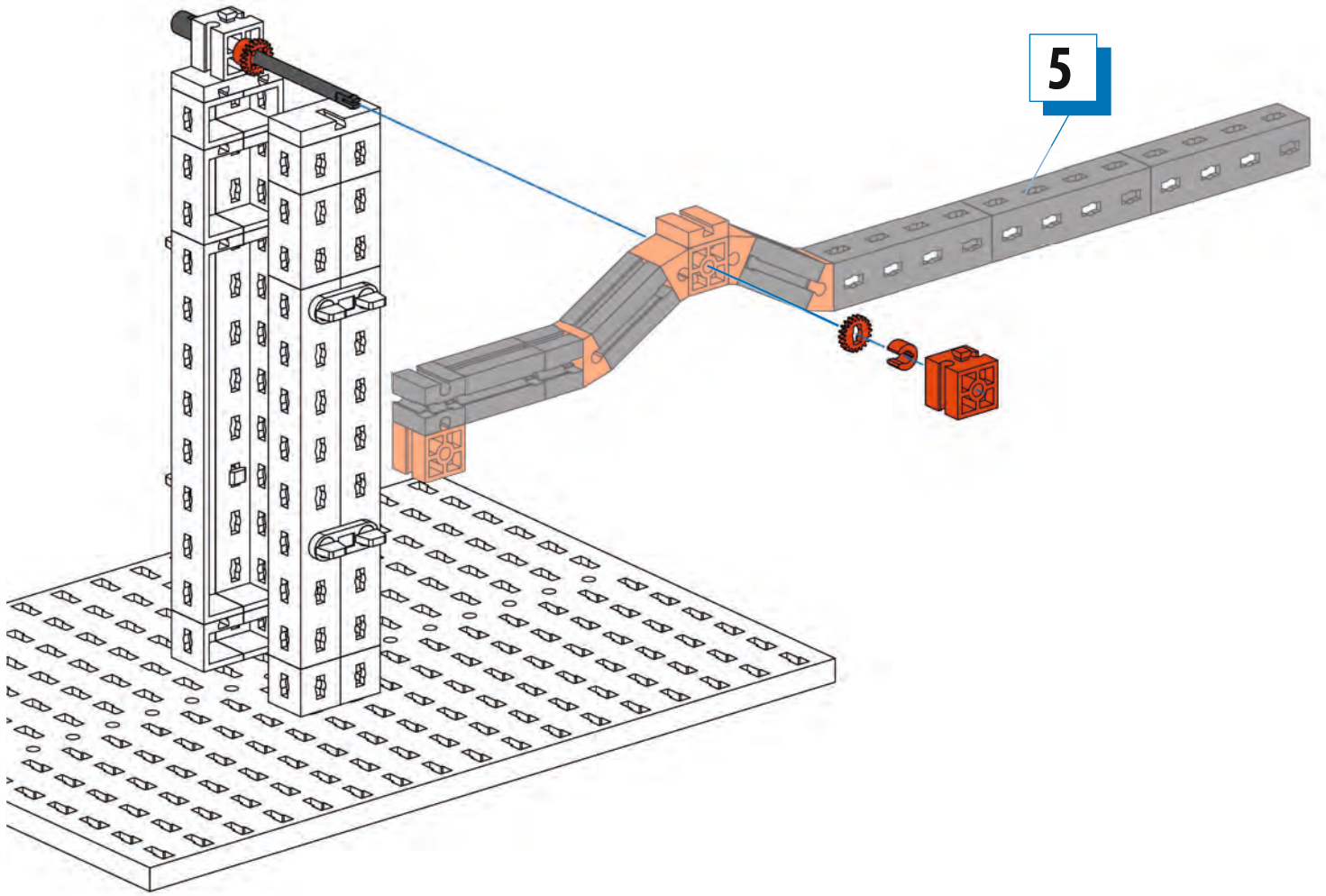

**7** 2x 90 2x 2x 4x 2x

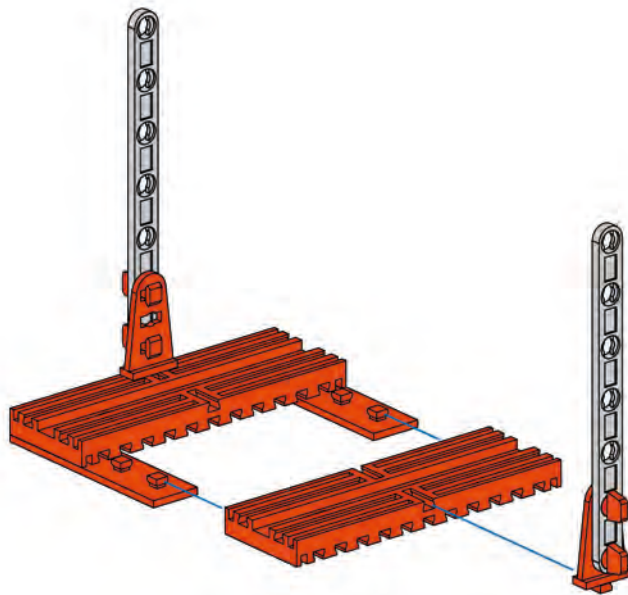



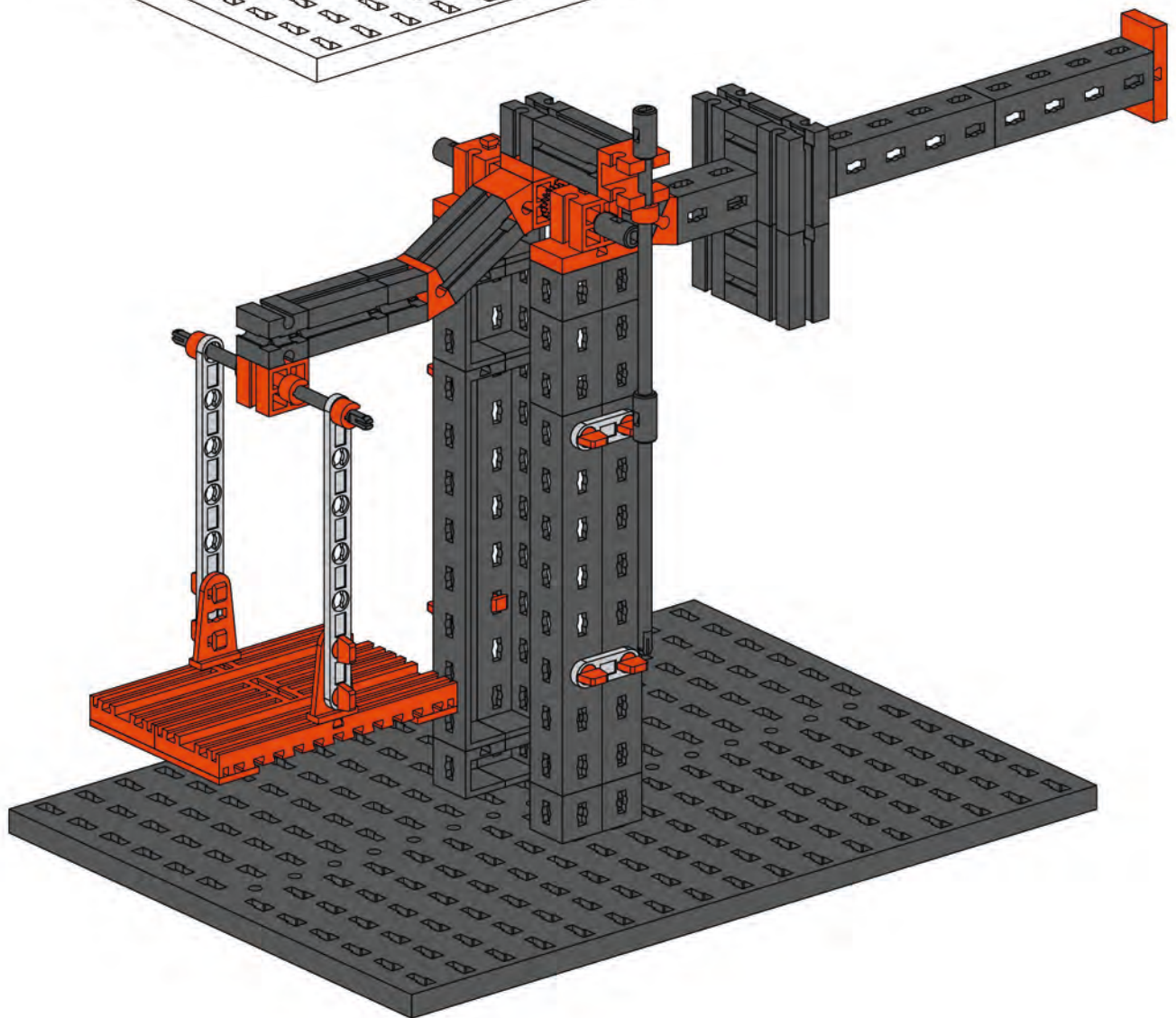
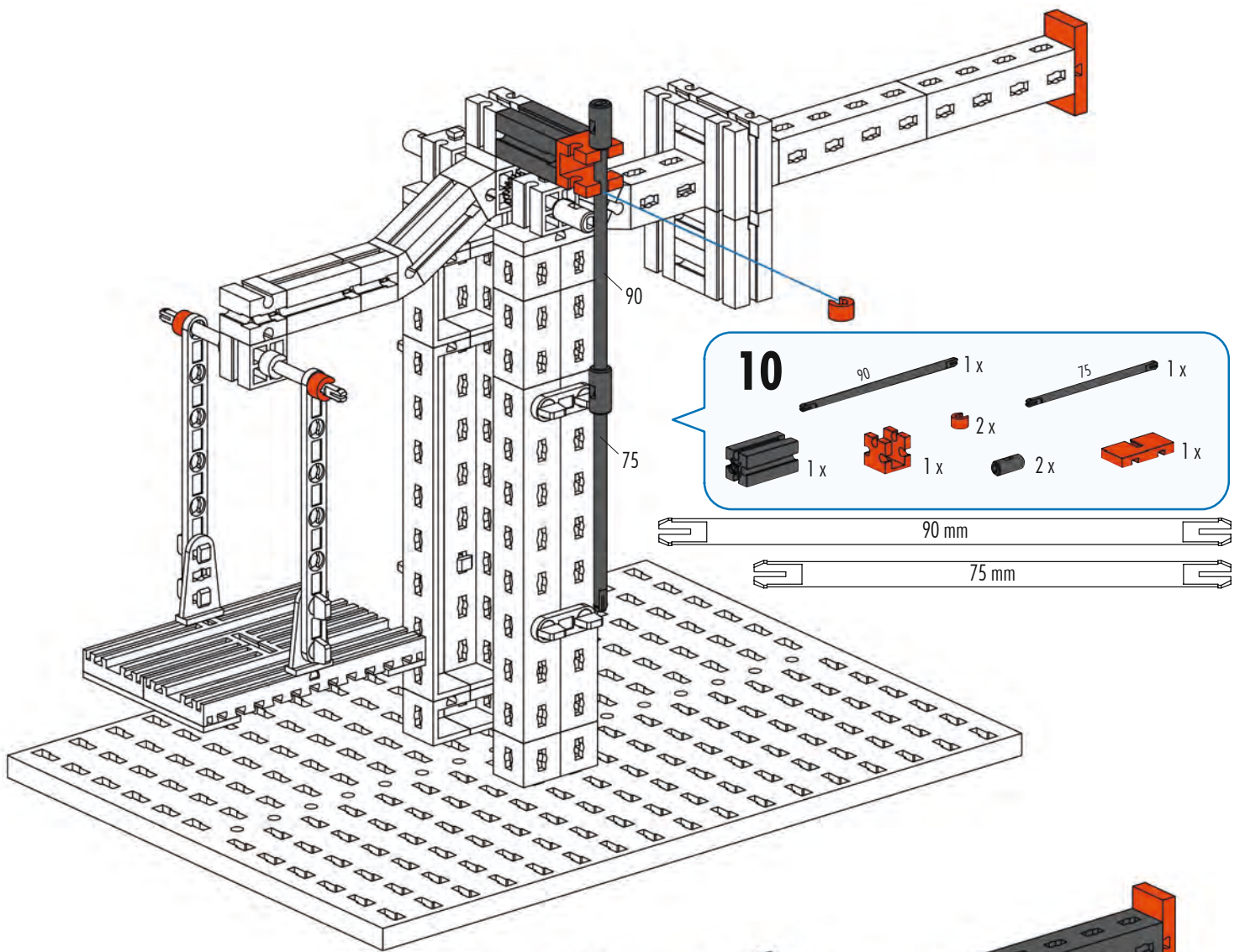

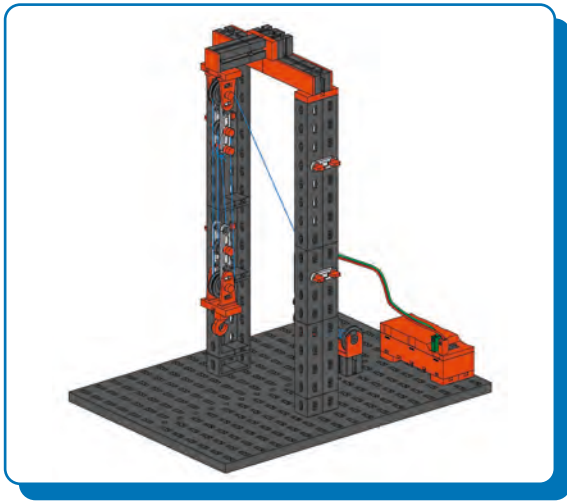

Flaschenzug  
Lifting tackle  
Palan

Takel  
Polipasto  
Talha

Paranco  
Таль  
滑轮组

**1**

1x  
4x  
2x  
1x  
1x

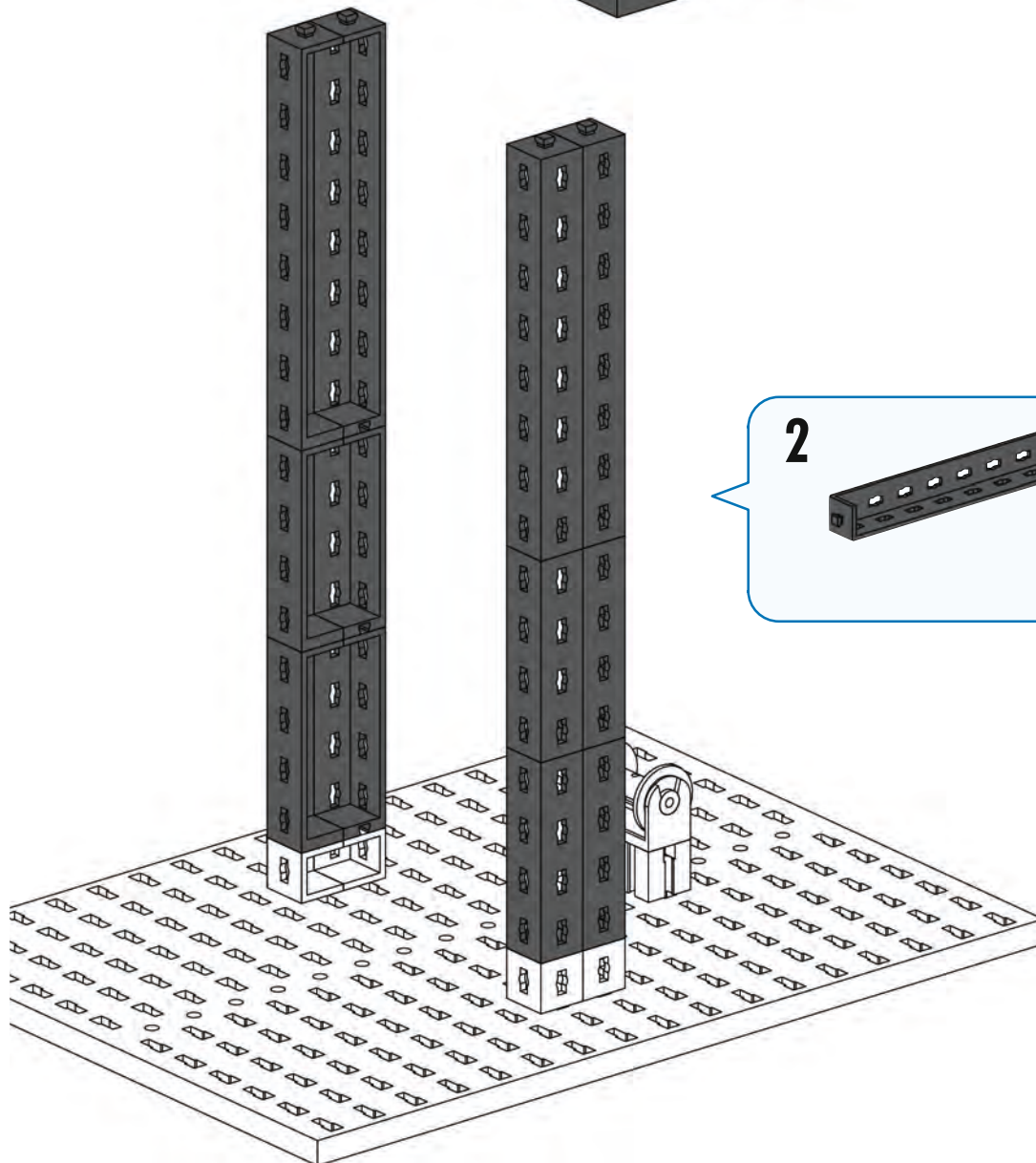
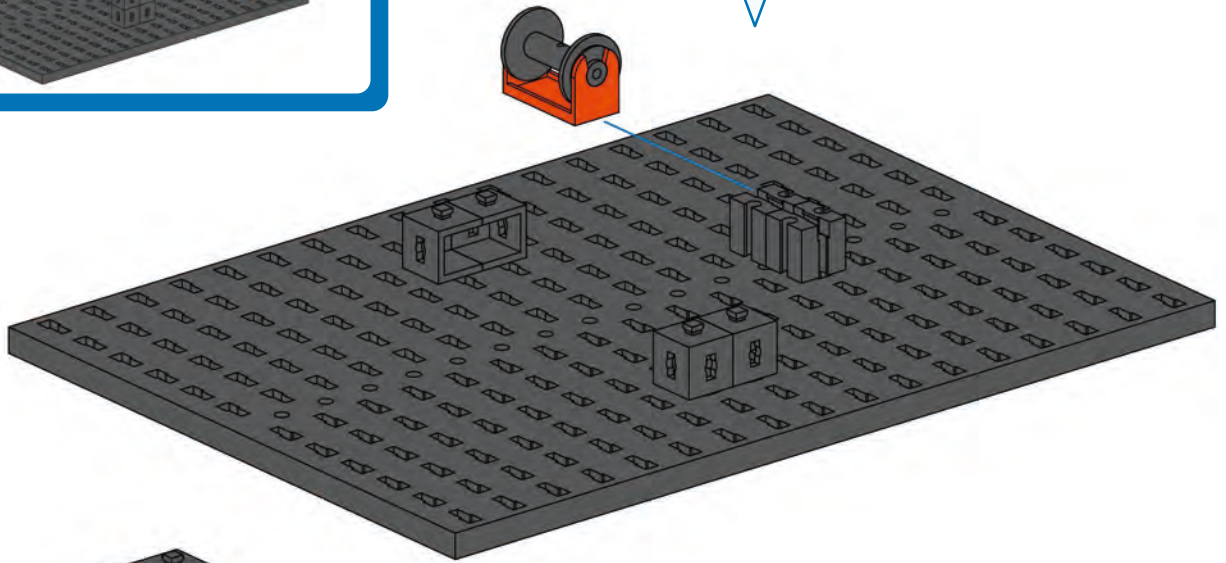

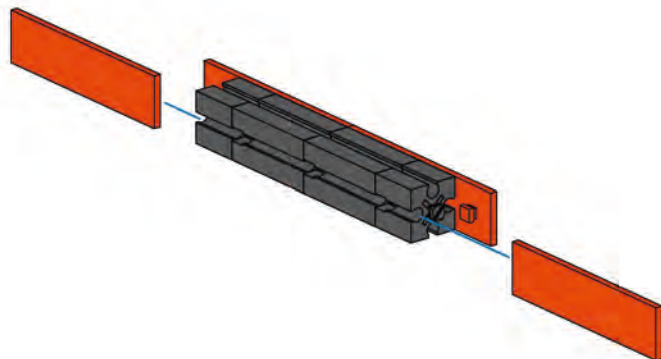
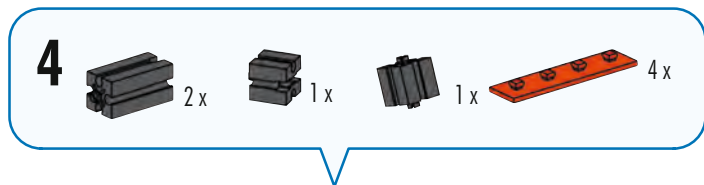
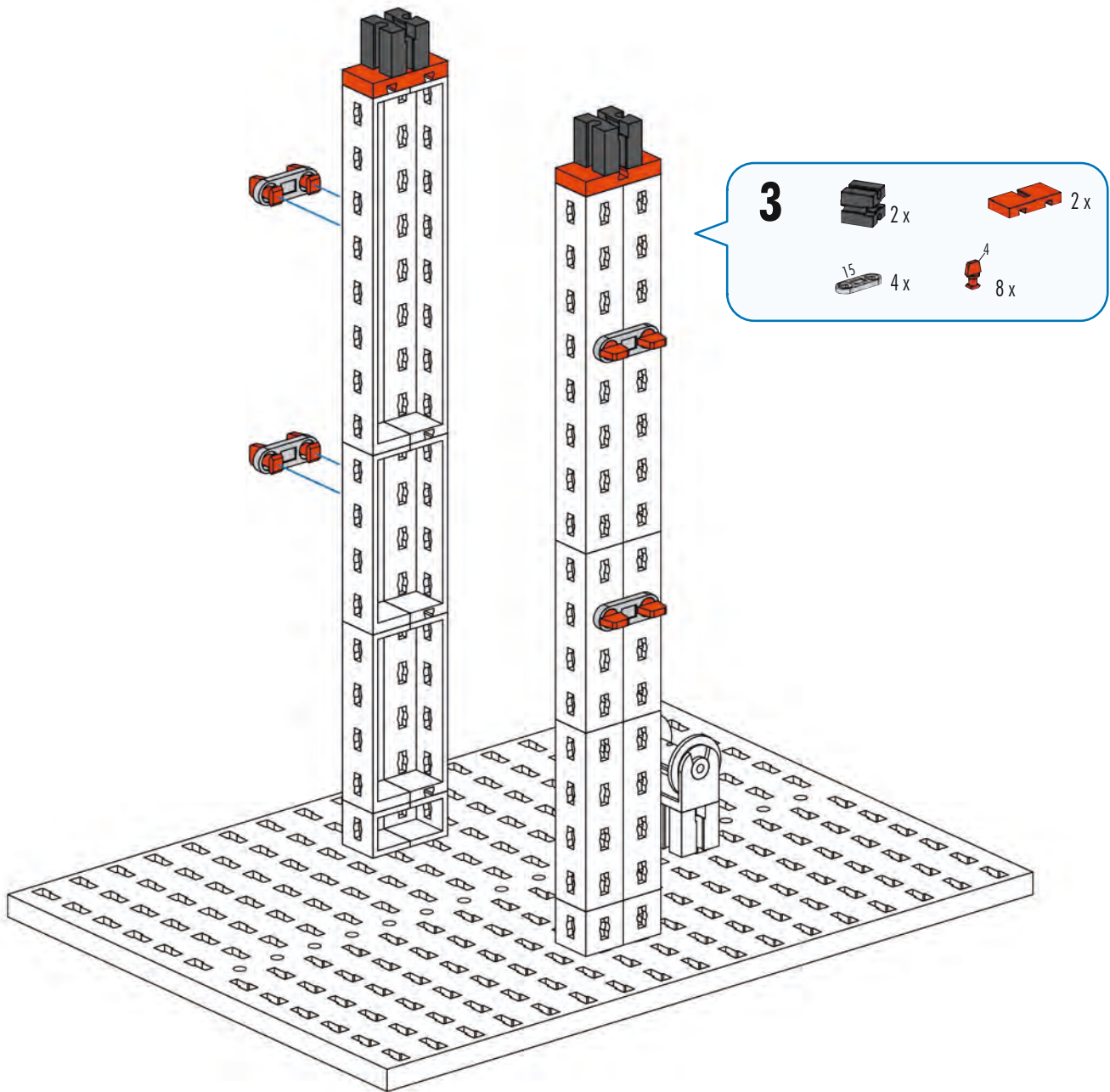

**2**

4x  
8x





**5**  2x  1x  2x

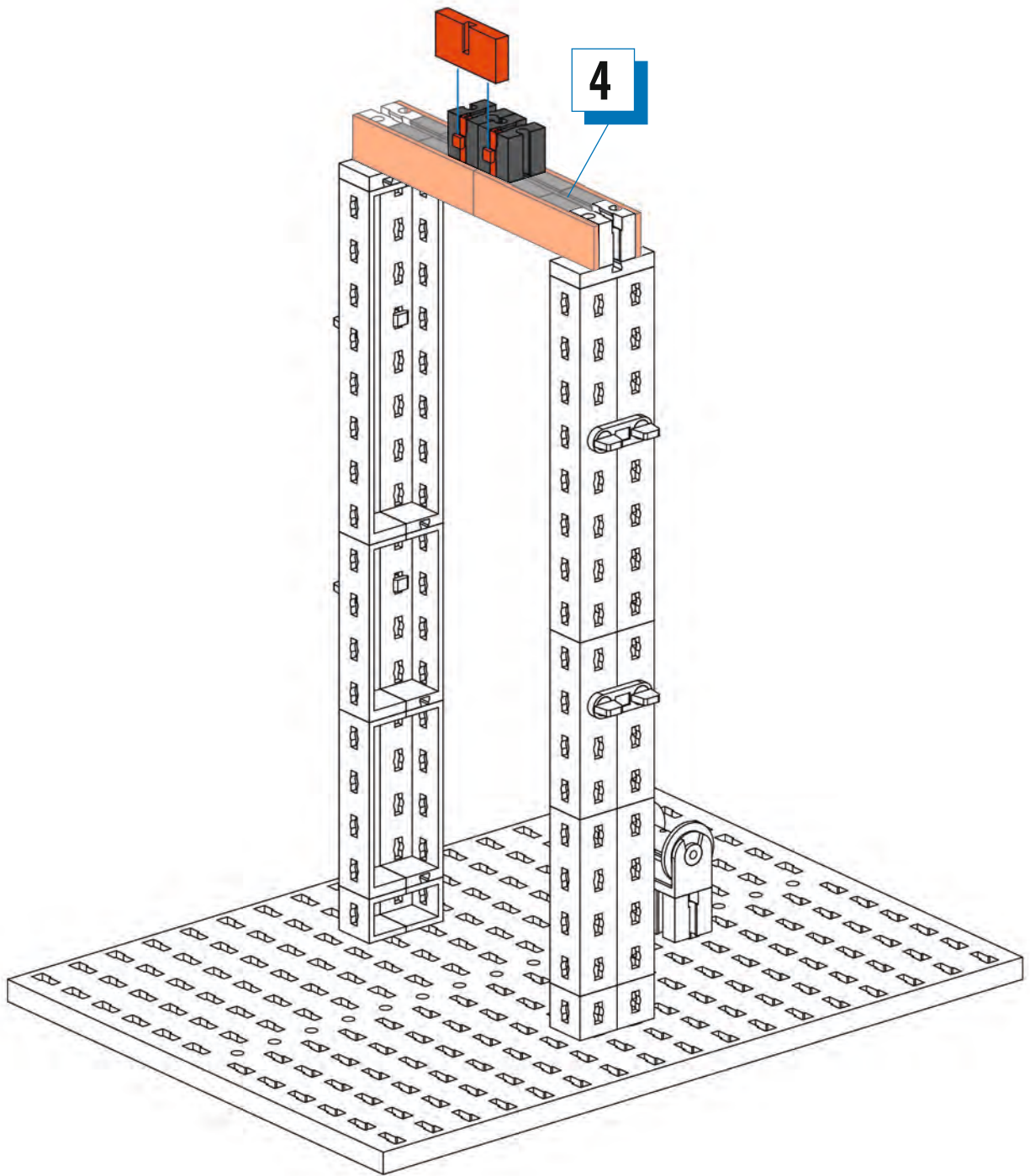

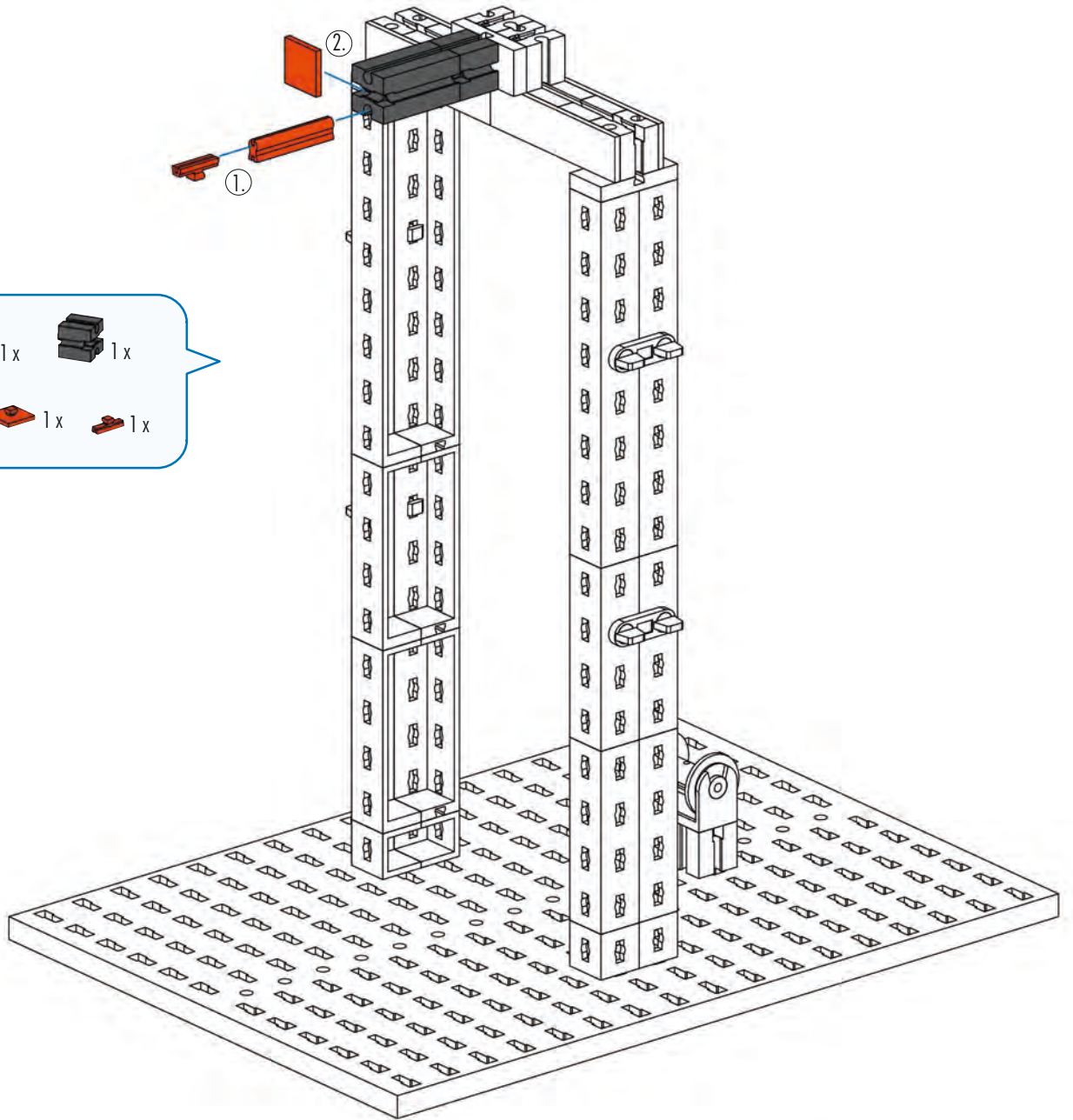

**6**

- 1x Black Technic axle
- 1x Black Technic axle
- 1x Red Technic axle (30)
- 1x Red Technic plate (1x1)
- 1x Red Technic pin

**7**

- 4x Red Technic axle (45)
- 2x Black Technic axle
- 2x Red Technic axle

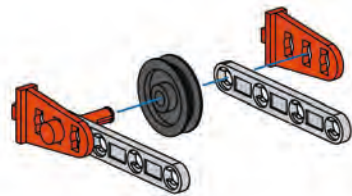

**2 x**

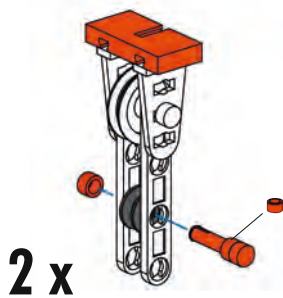

**2 x**

**8**

- 2x Red Technic plate (1x3)
- 2x Black Technic axle
- 4x Red Technic pin
- 2x Red Technic axle

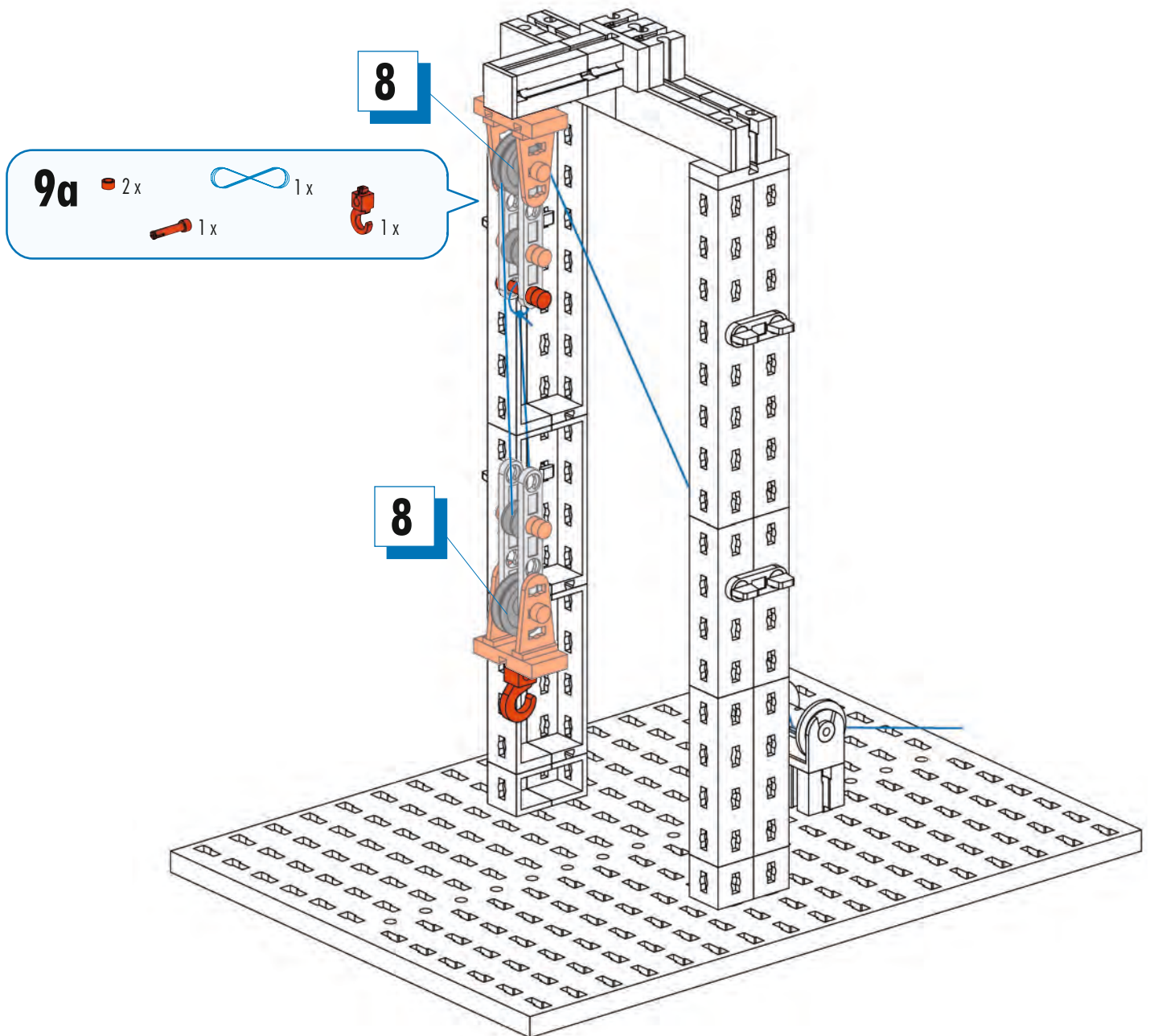
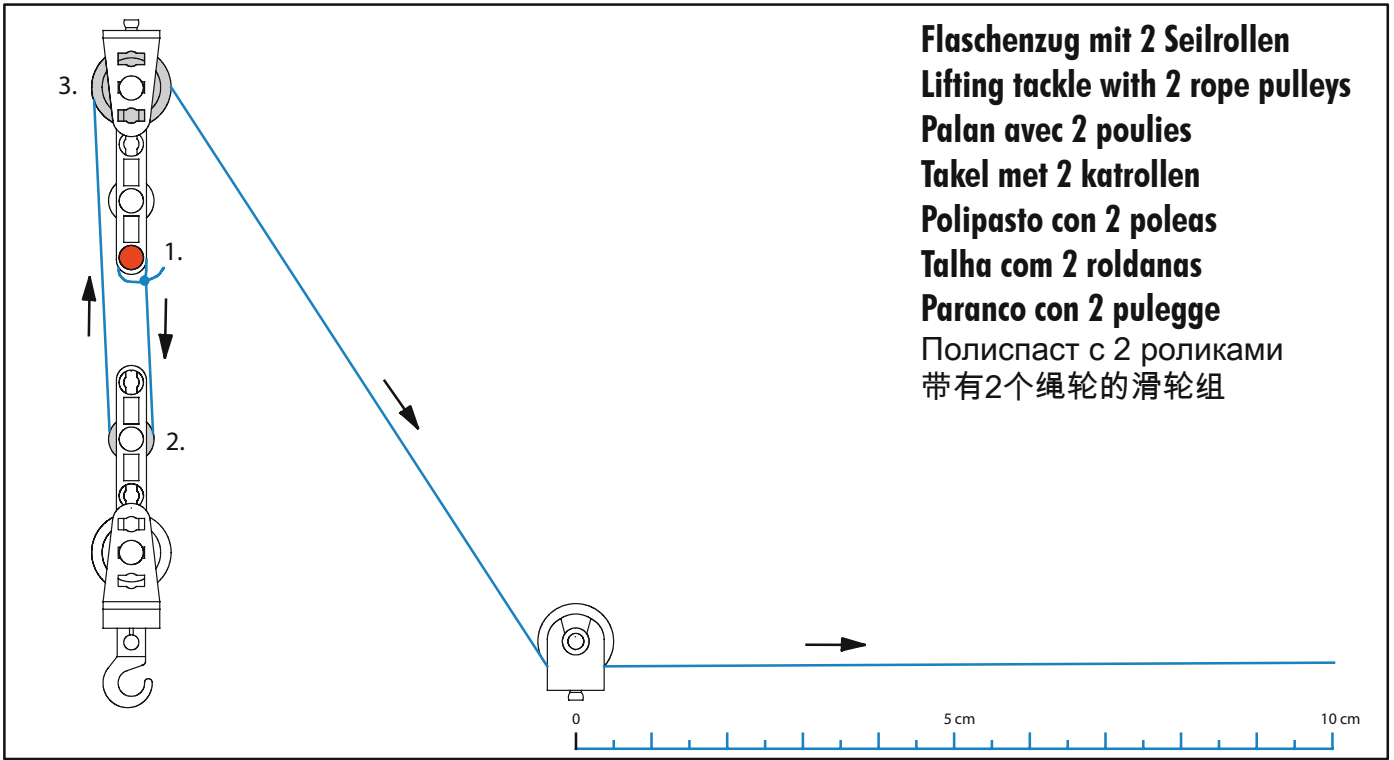

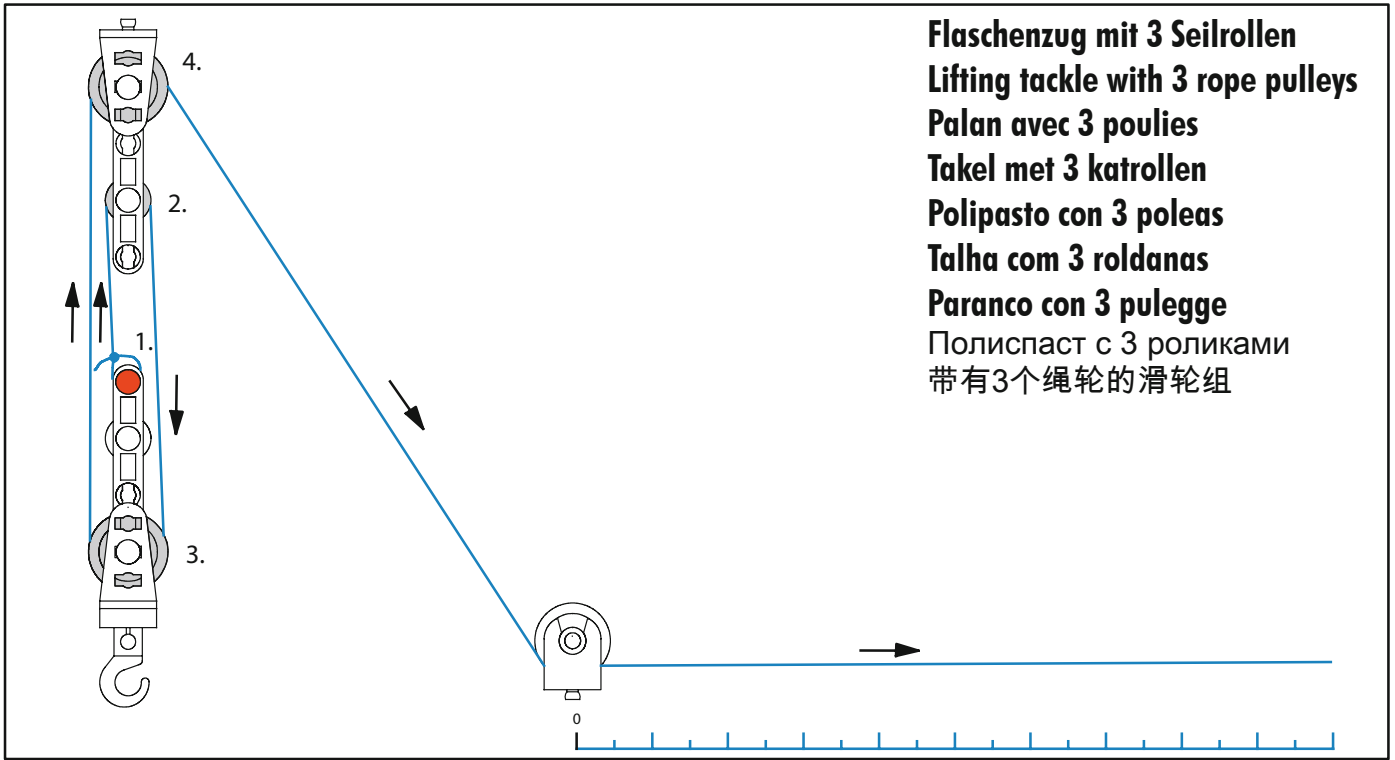

umbauen  
 modify  
 modifier  
 veranderen  
 modificar  
 modificar  
 modificare  
 переделать  
 改装

**9a**

**9b**

2 x

1 x

1 x

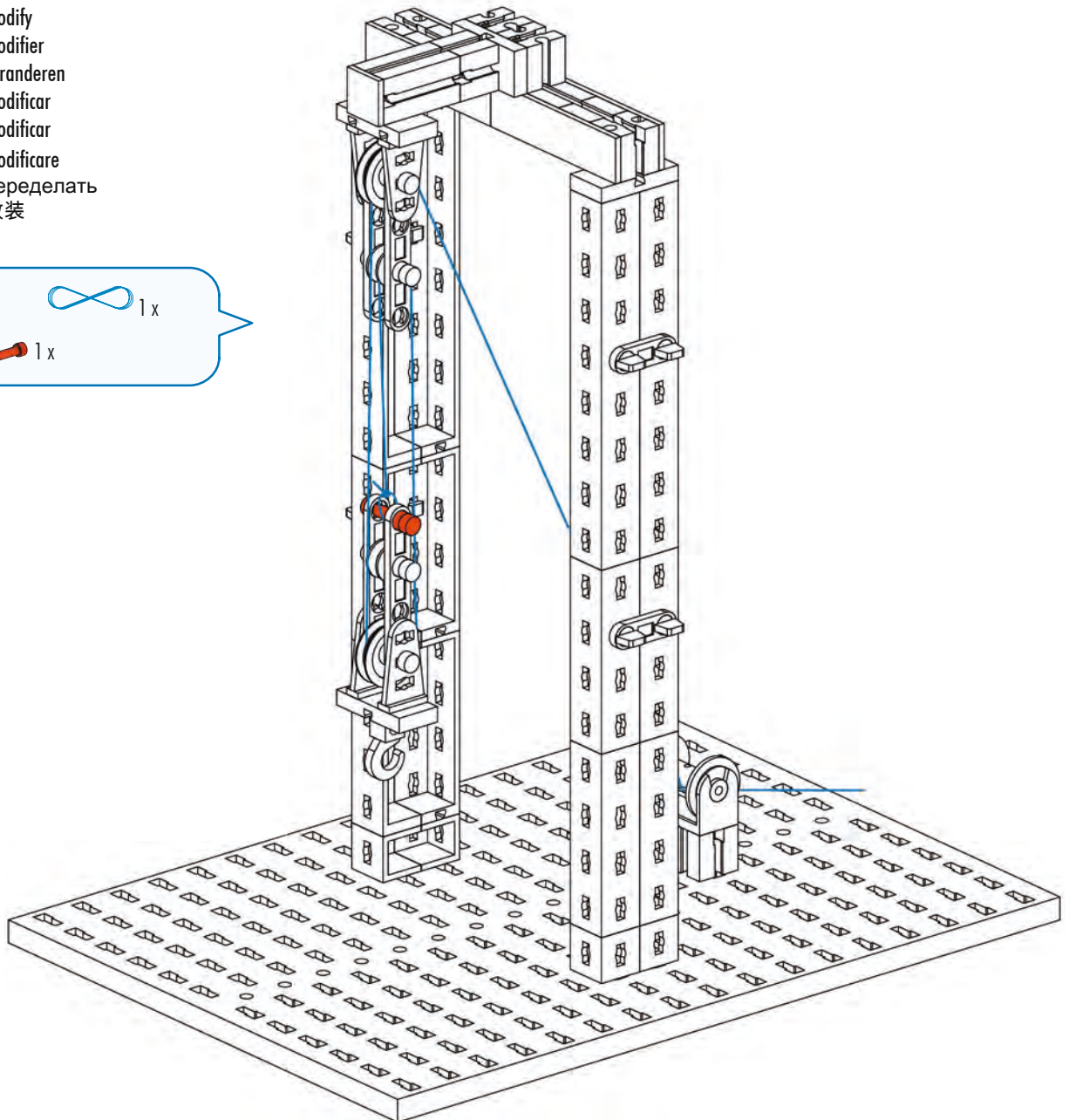

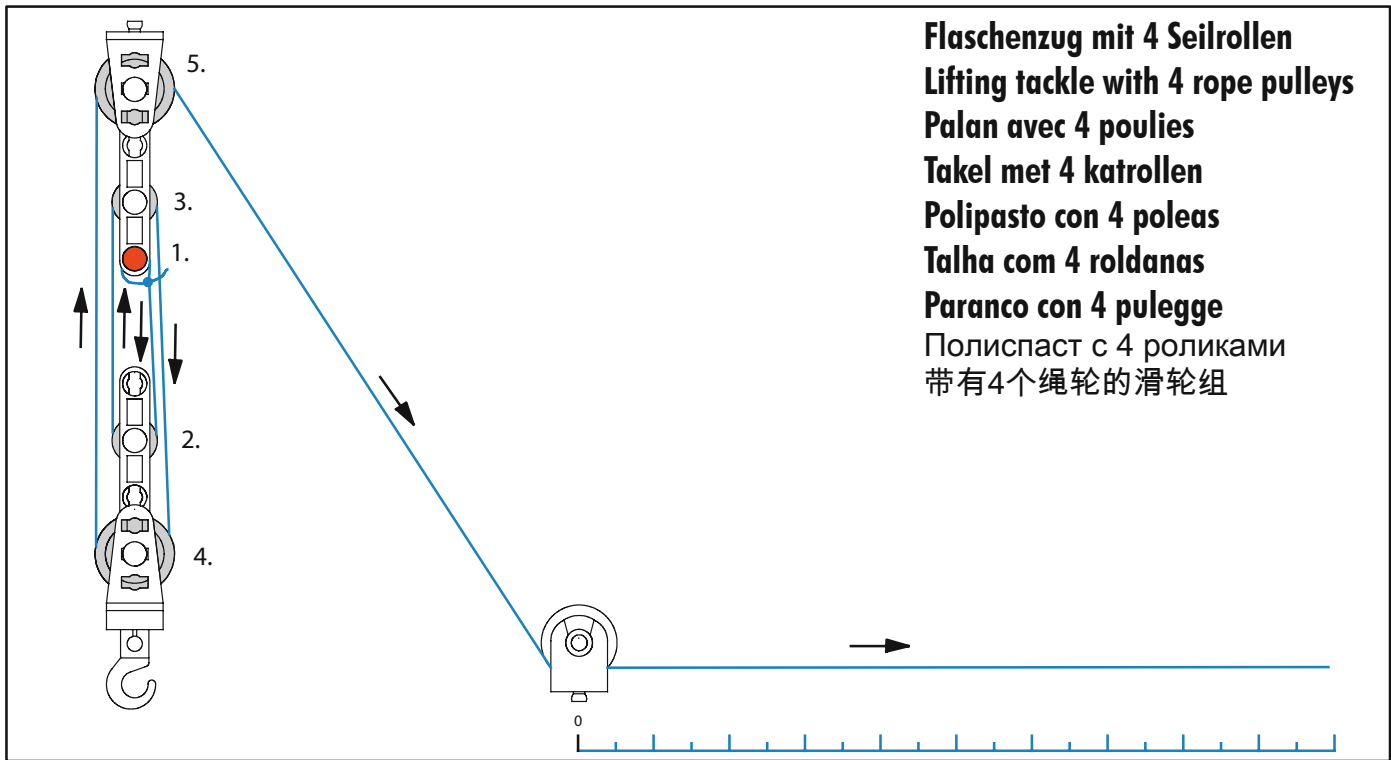

**9b**

umbauen  
 modify  
 modifier  
 veranderen  
 modificar  
 modificar  
 modificare  
 переделать  
 改装

**9c**

2 x



1 x



1 x

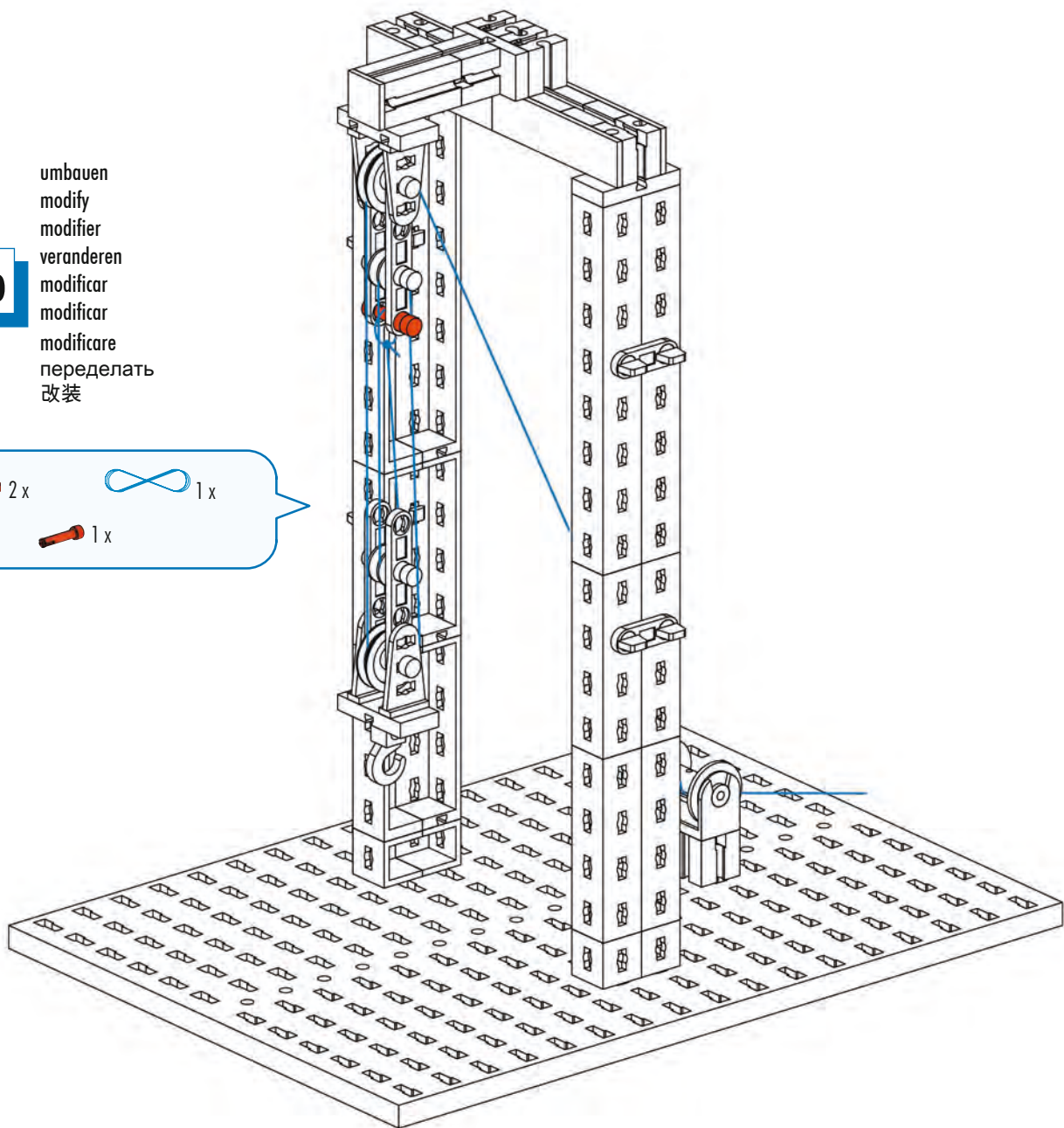

Motorisierung  
Motor unit  
Motorisation

Motorising  
Motorización  
Motorização

Motorizzazione  
Моторизация  
机动化

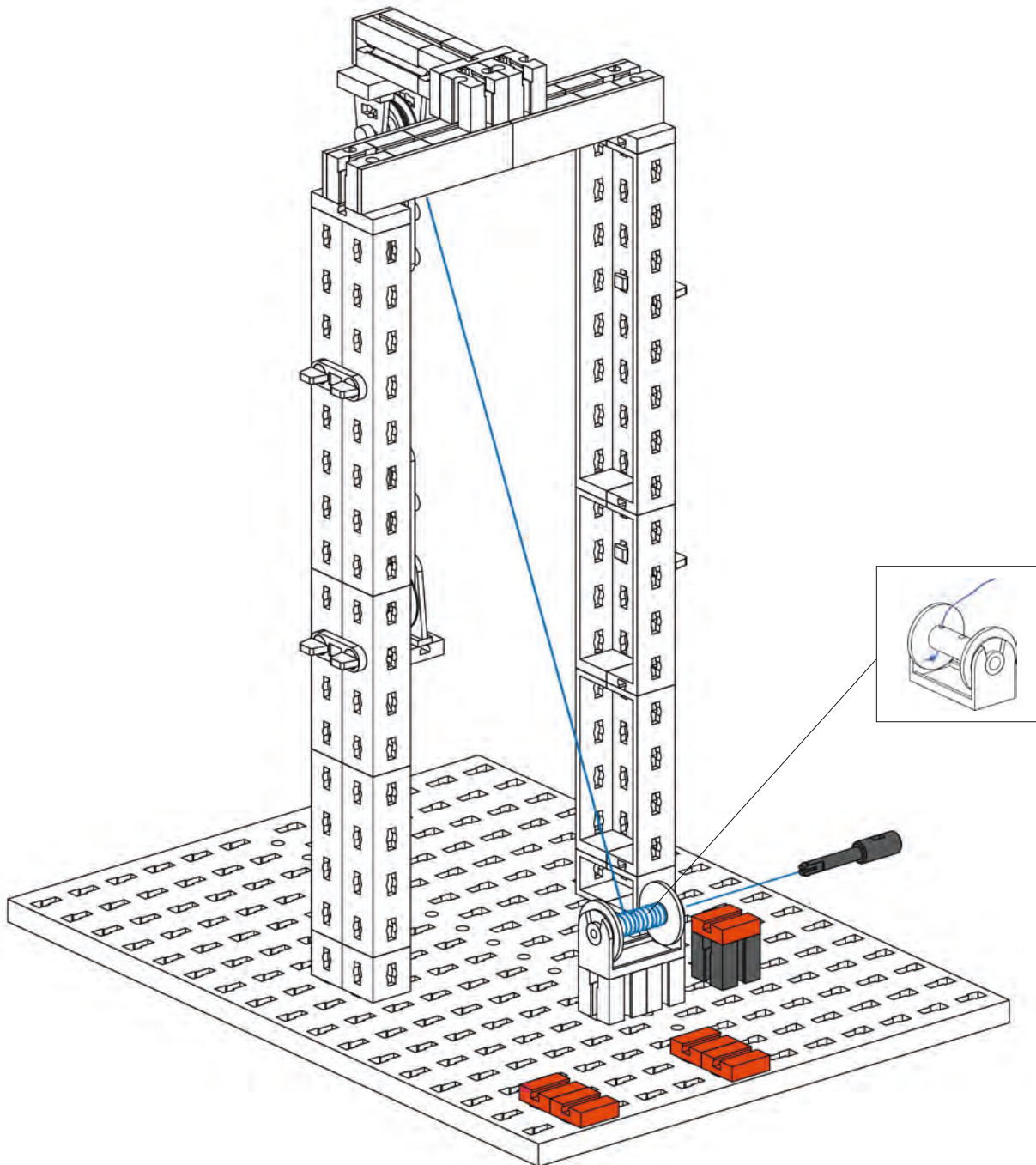
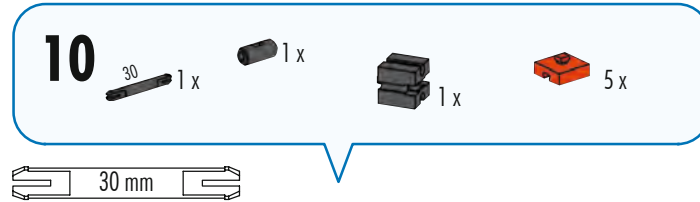

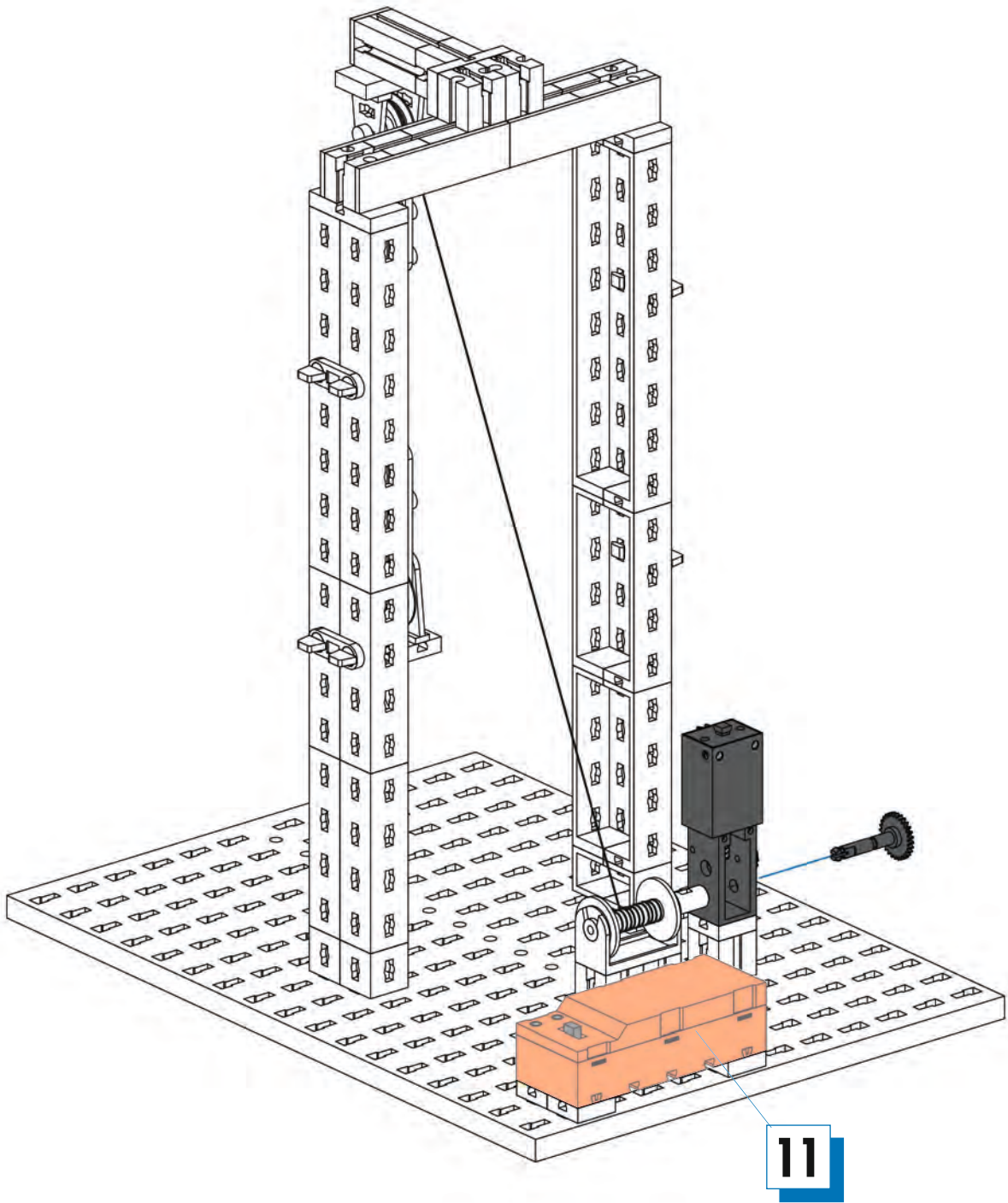
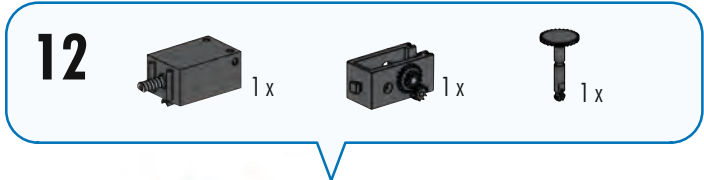
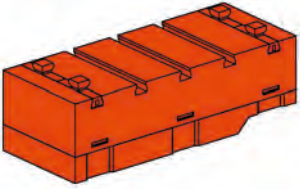
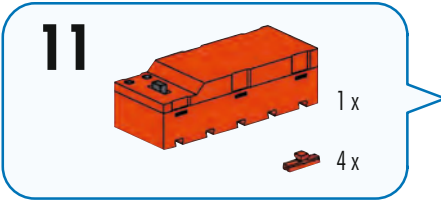

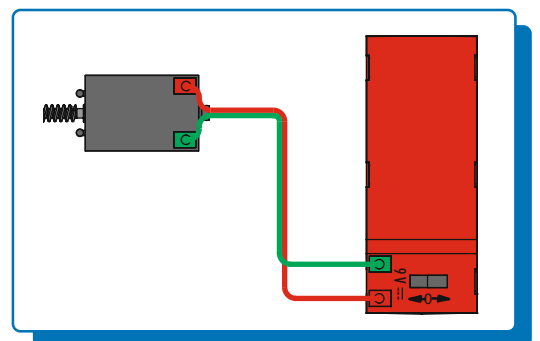
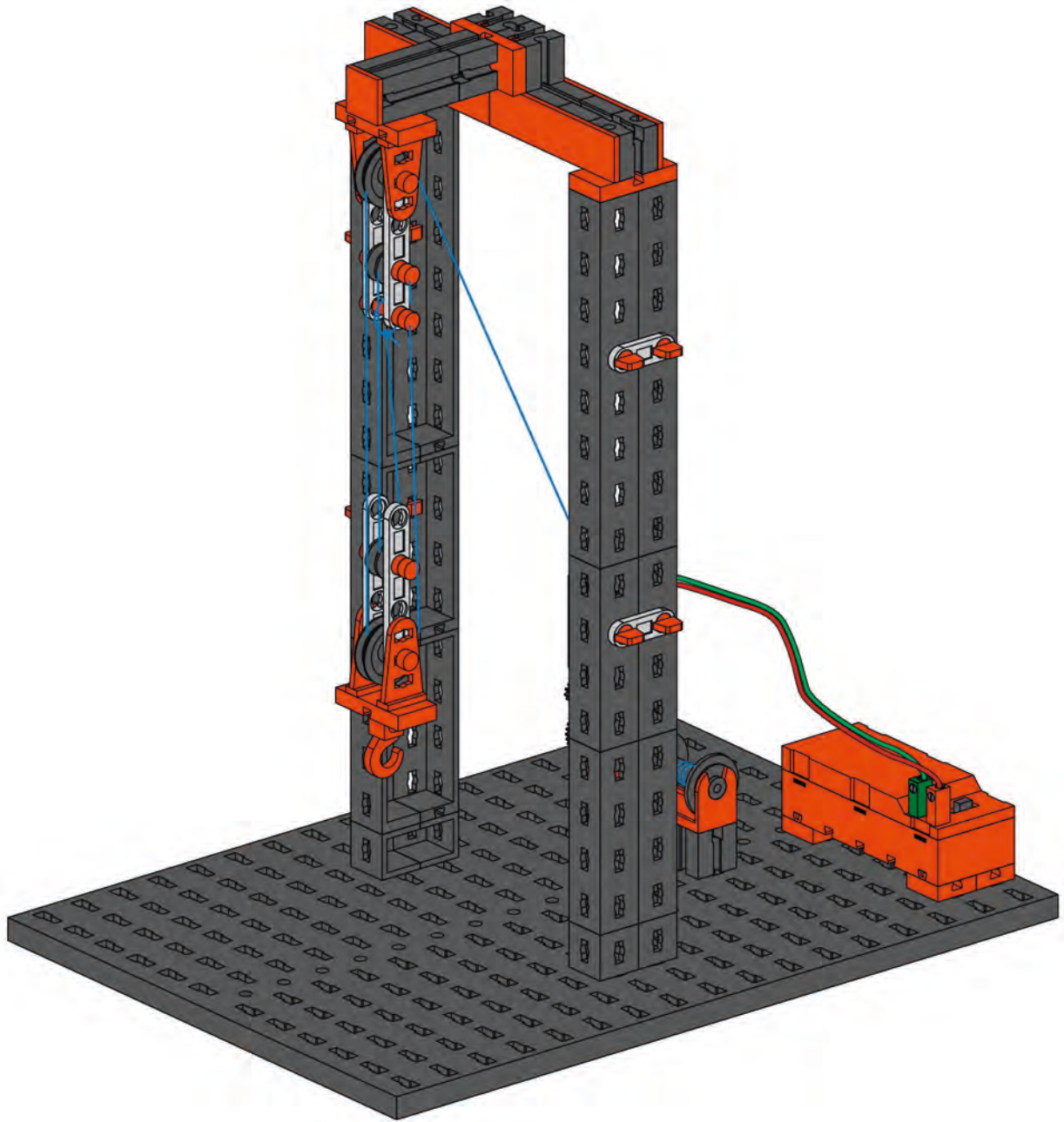



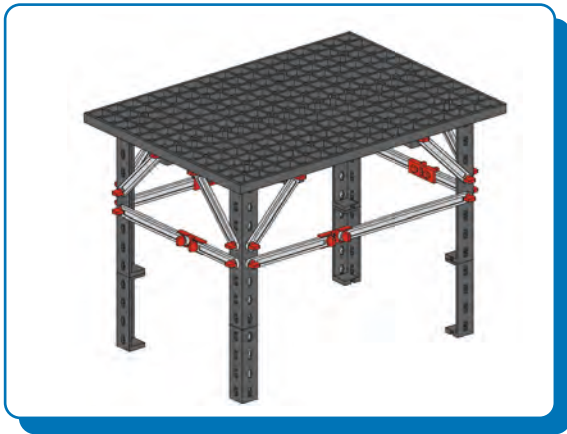

Tisch  
Table  
Table



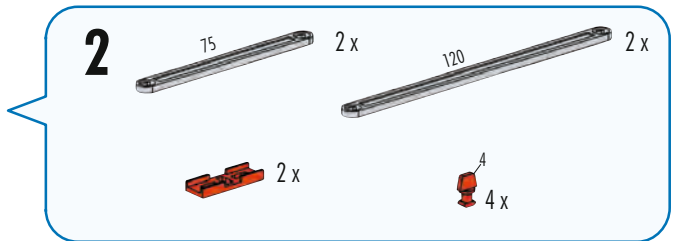
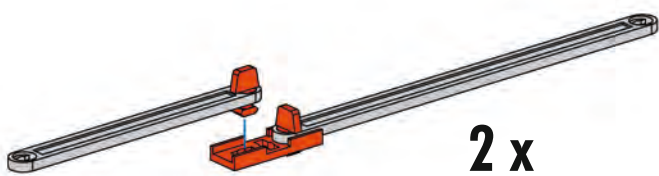
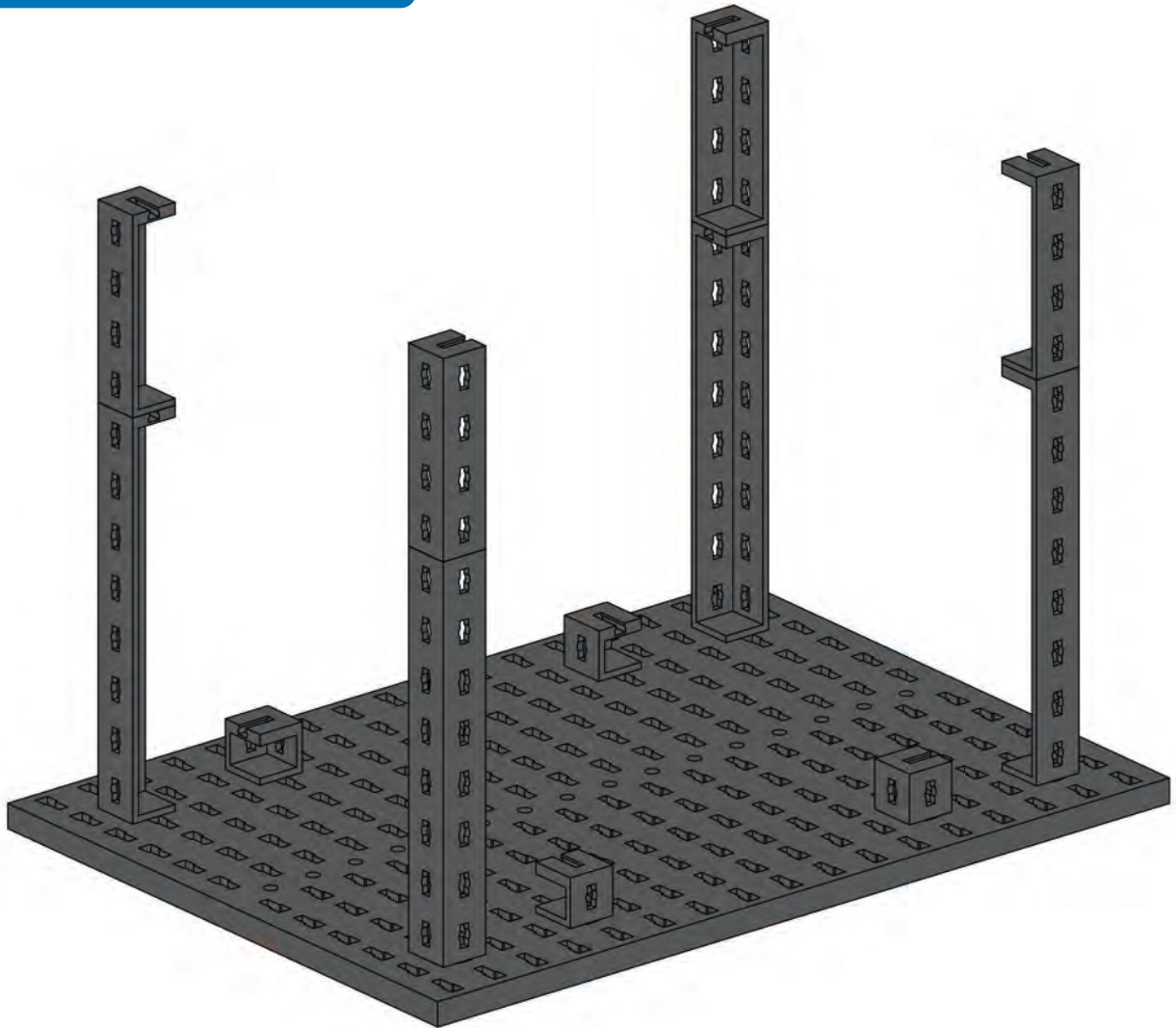
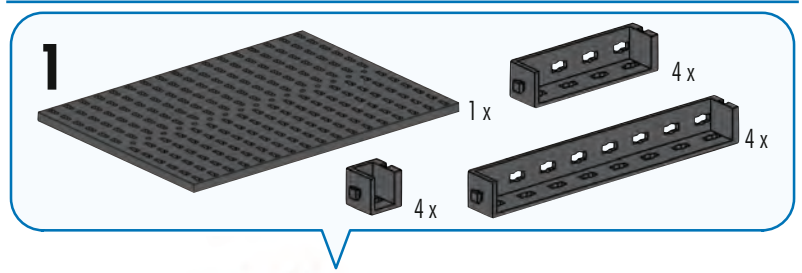

Tafel  
Mesa  
Mesa

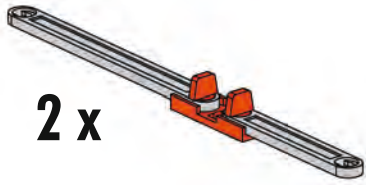
Tavola  
Стол  
工作







**3**

 75 2 x	 45 2 x
 2 x	 4 x

**4**

 8 x	 4 x
---	---

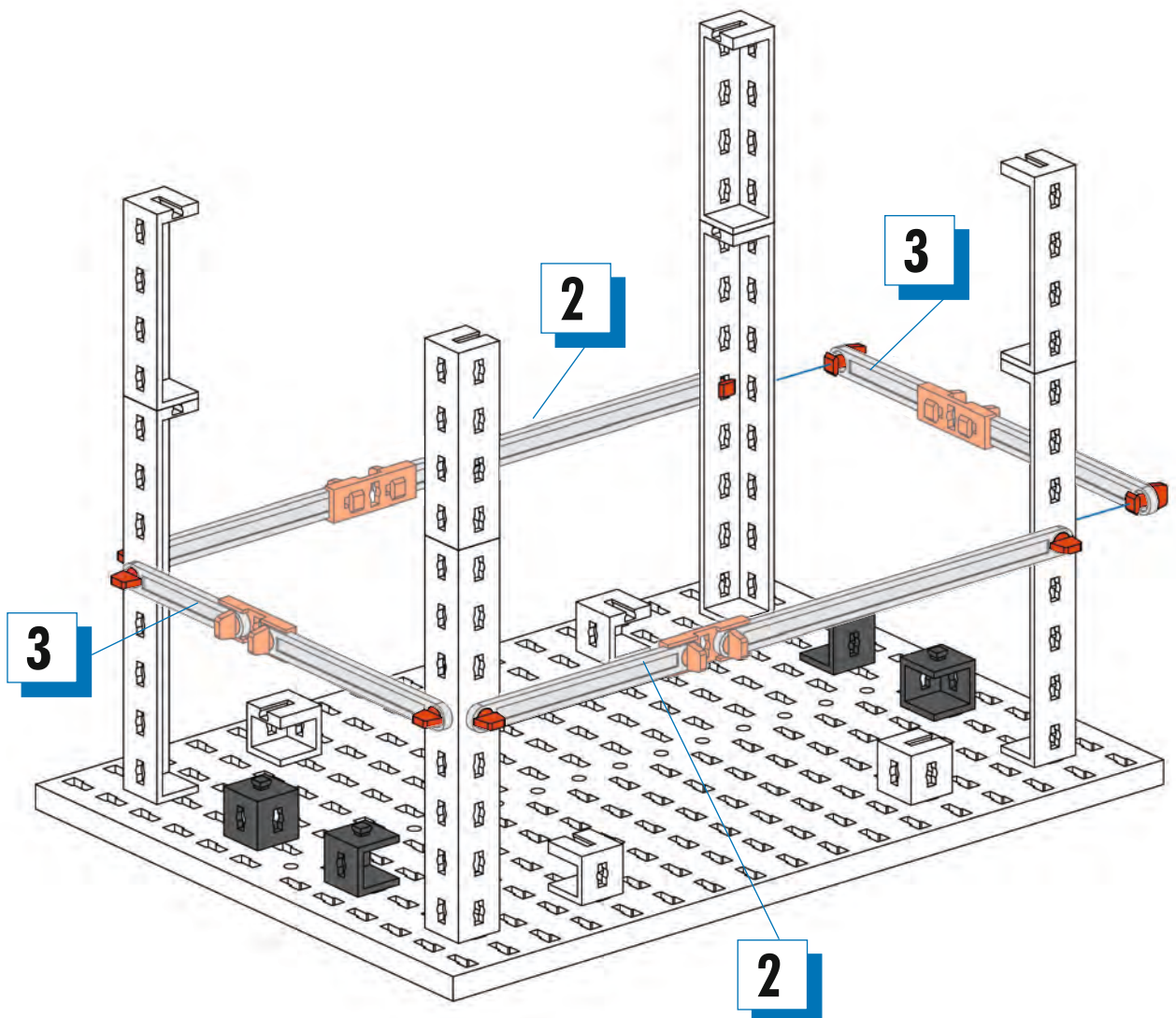

5

63,6 8 x

A 16 x

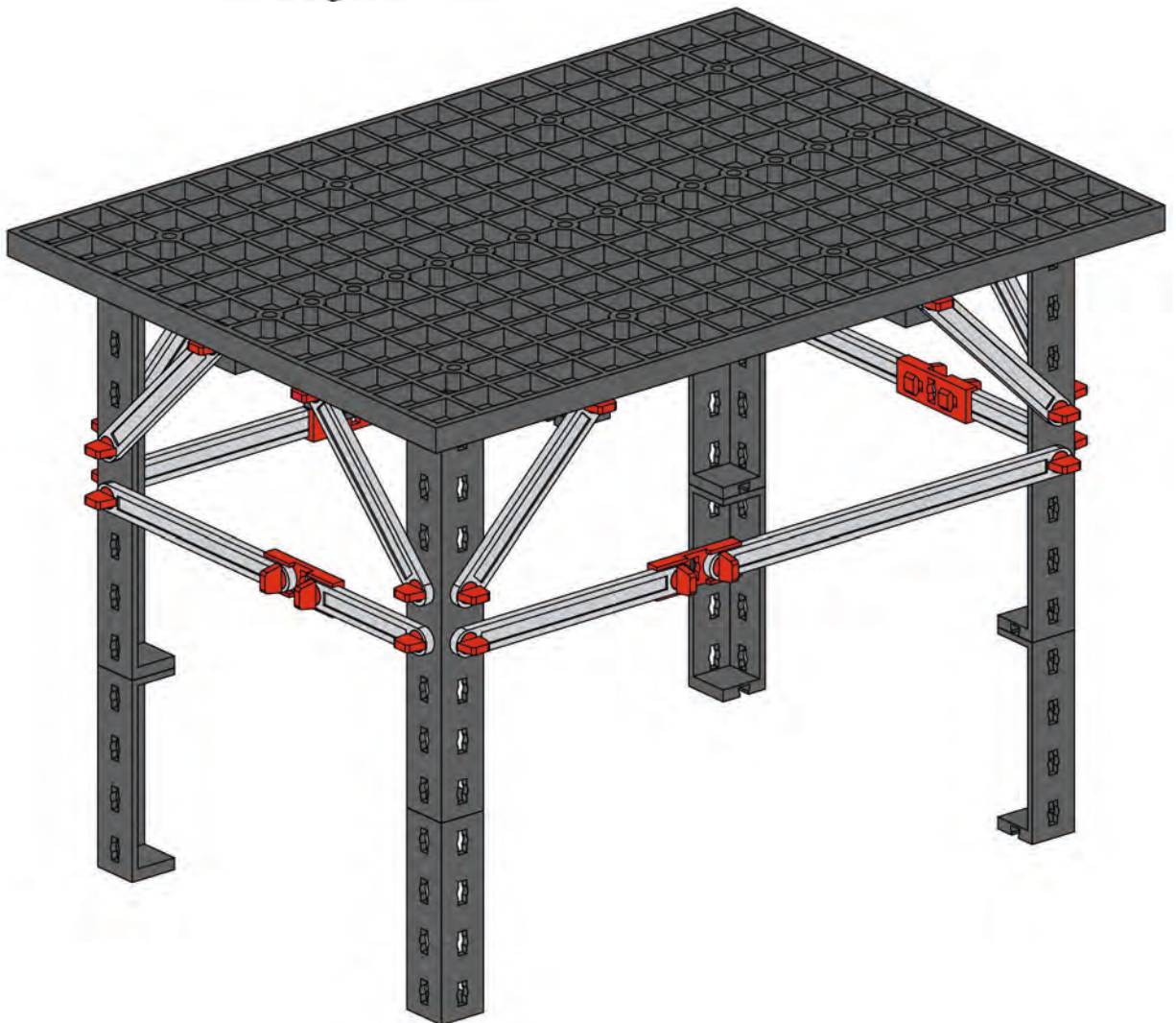
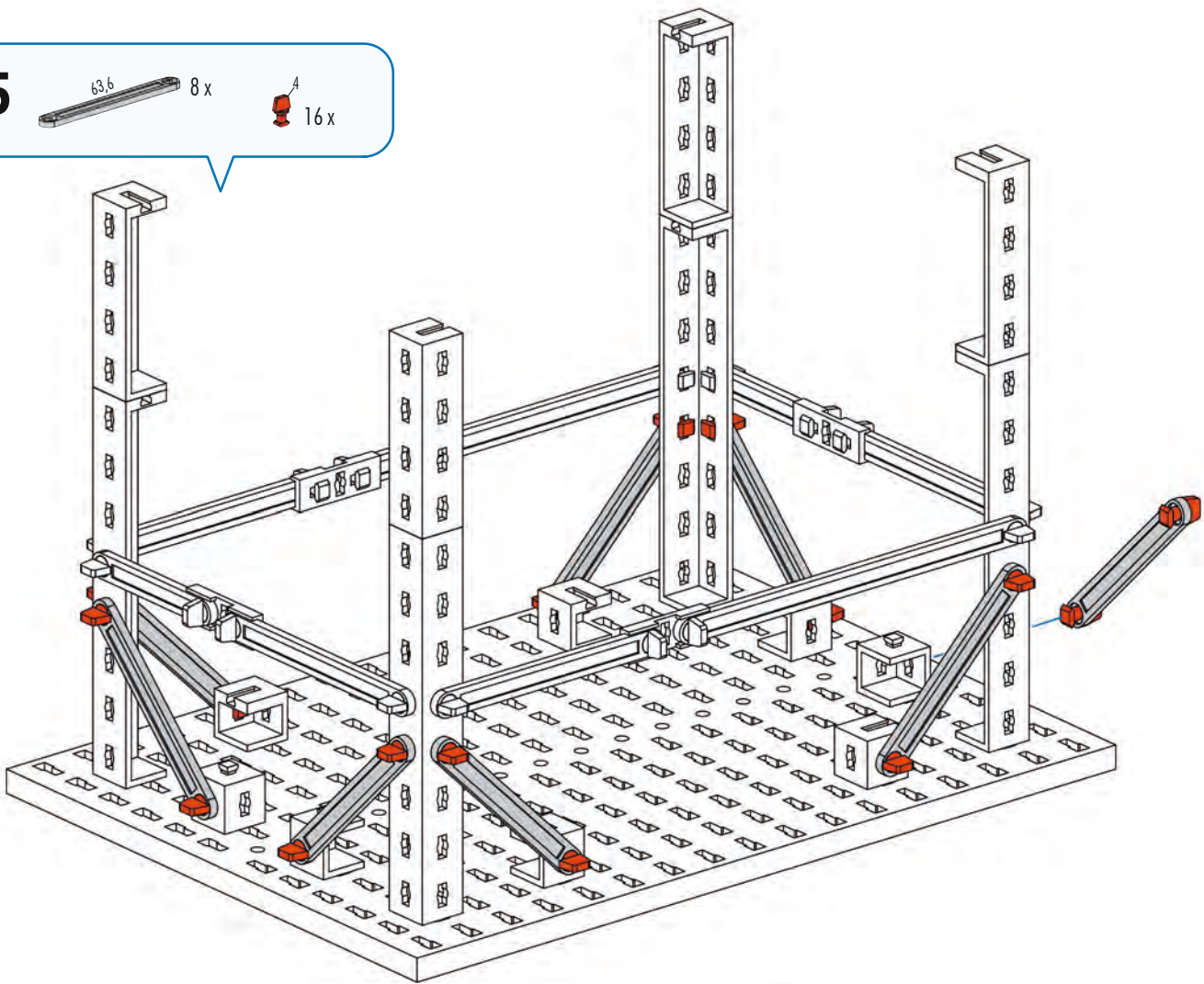



**Bockleiter**  
**Double ladder**  
**Echelle double**

**Trapladder**  
**Escalera de tijera**  
**Escada de cavalete**

**Scala a libro**  
**Стремянка**  
**人字梯**

**1**

2 x  
 4 x  
 8 x  
 2 x  
 1 x

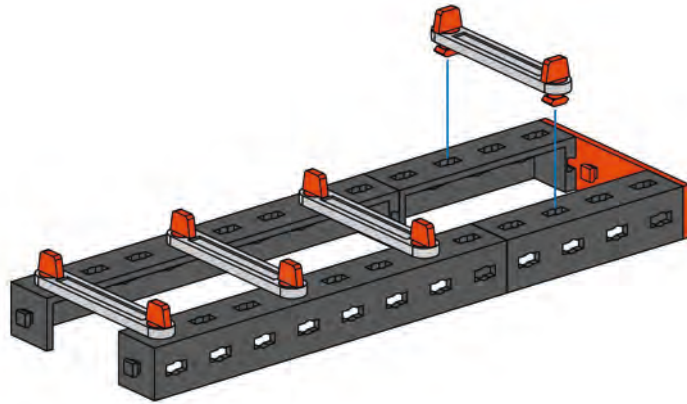

**2**

42.4 2 x  
 60° 2 x  
 7.5 1 x  
 2 x  
 2 x

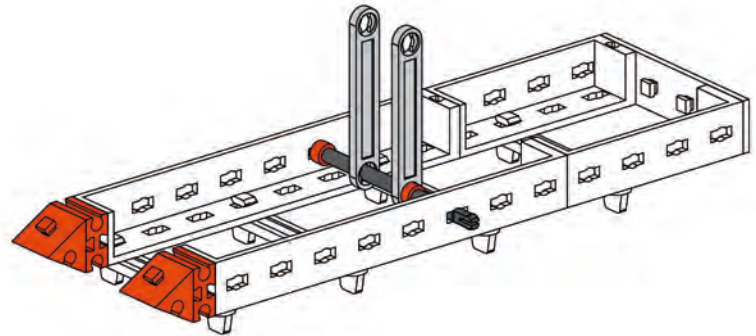
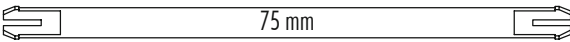

**3**

2 x  
 2 x

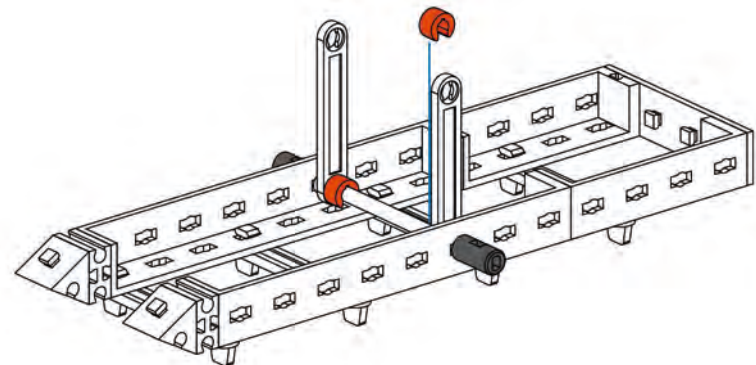

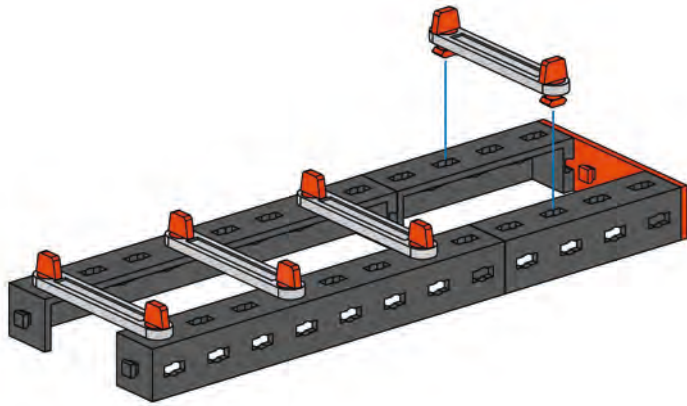

**4**

- Grey beam (11 holes) 2 x
- Grey beam (3 holes) 2 x
- Grey pin (45) 4 x
- Orange pin (A) 8 x
- Orange beam (4 holes) 1 x

**5**

- Grey pin (42.A) 2 x
- Orange pin (60°) 2 x
- Grey pin (15) 1 x
- Grey pin 2 x
- Orange pin 2 x
- Orange pin 2 x



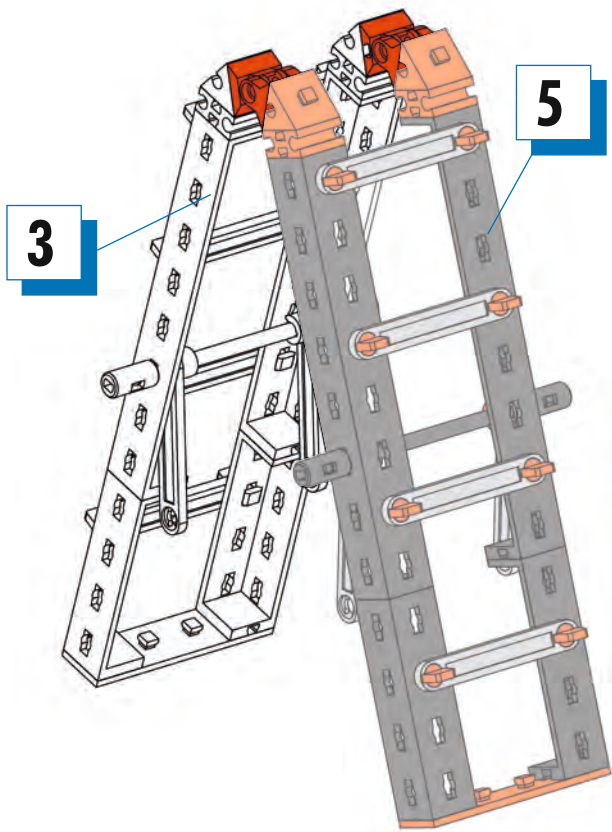
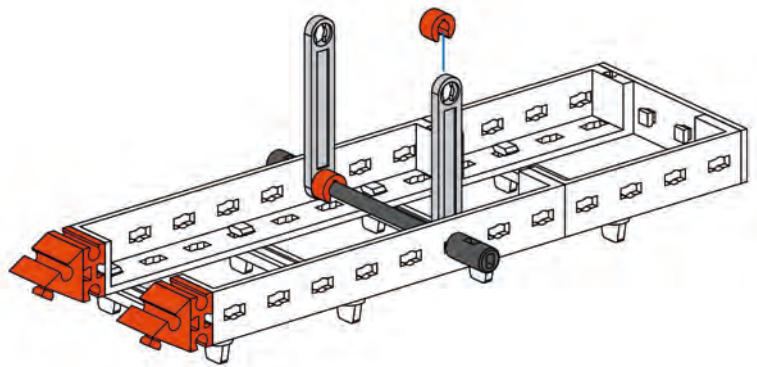

75 mm



**6**

- Orange pin 2 x

**7**

- 2 x 
- 2 x 
- 1 x  15
- 2 x 

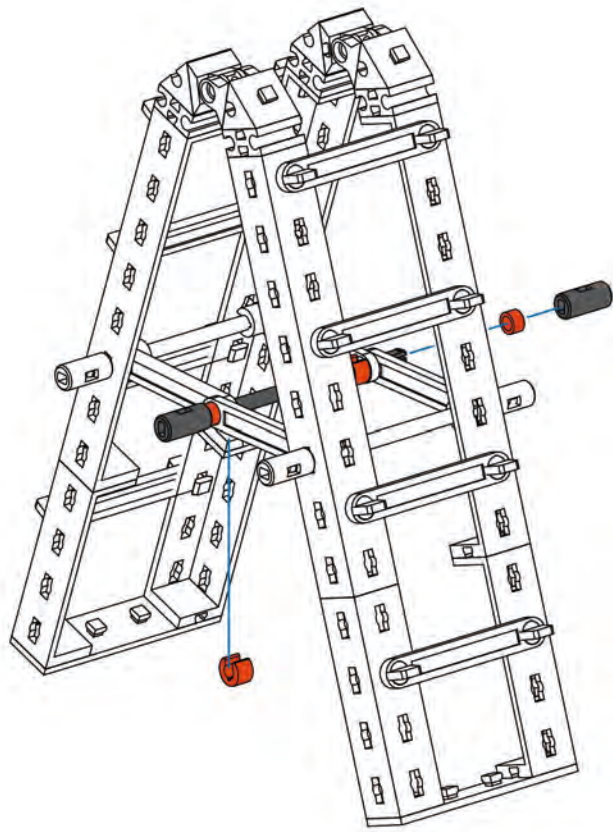
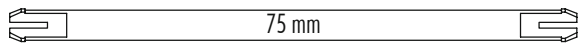

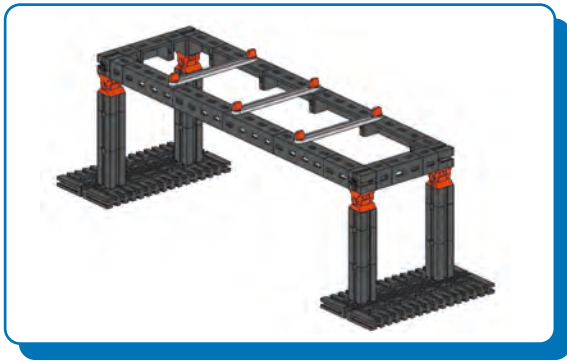

**Balkenbrücke**  
**Girder Bridge**  
**Pont à poutres droites**

**Balkenbrug**  
**Puente de vigas**  
**Ponte de travessa**

**Ponte a trave**  
**Балочный мост**  
**梁式桥**

**1**



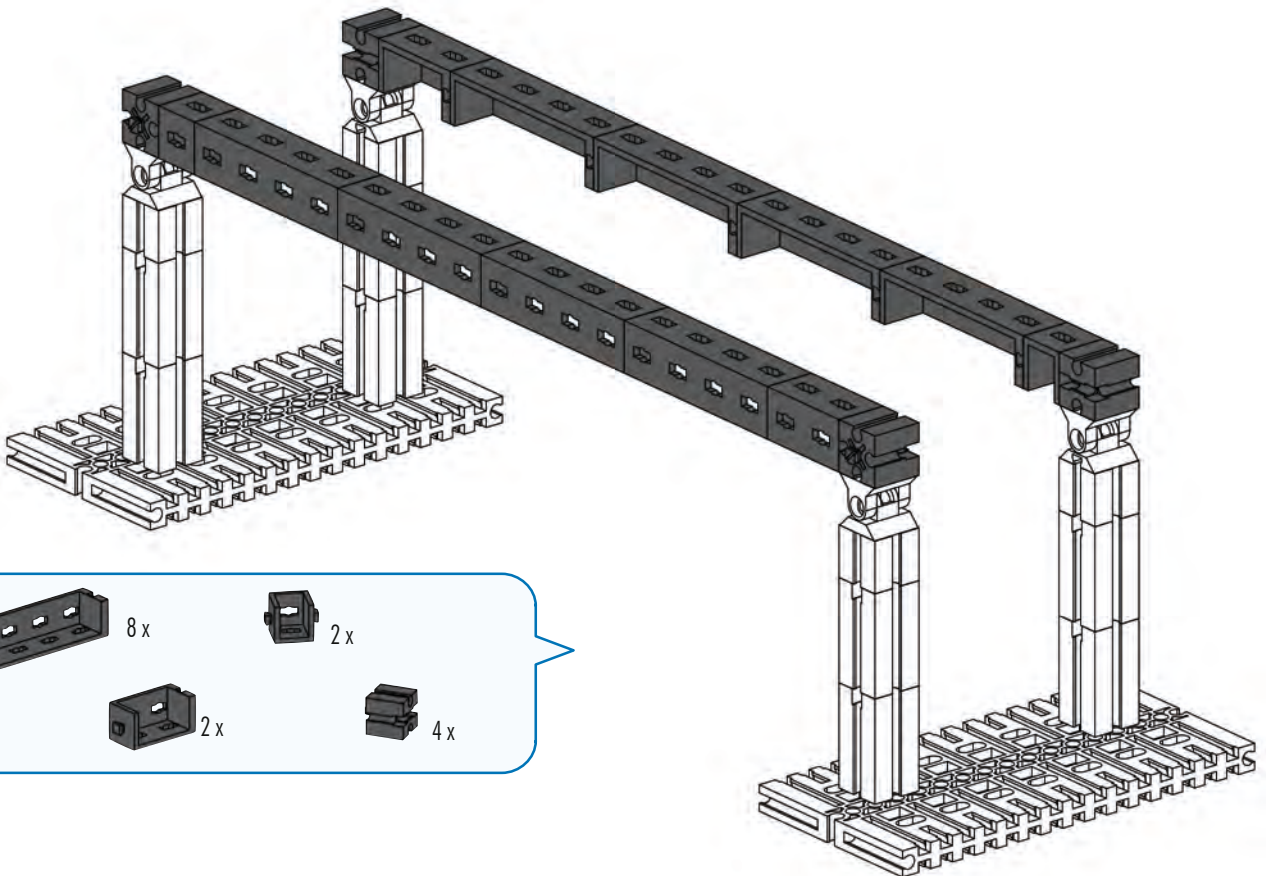
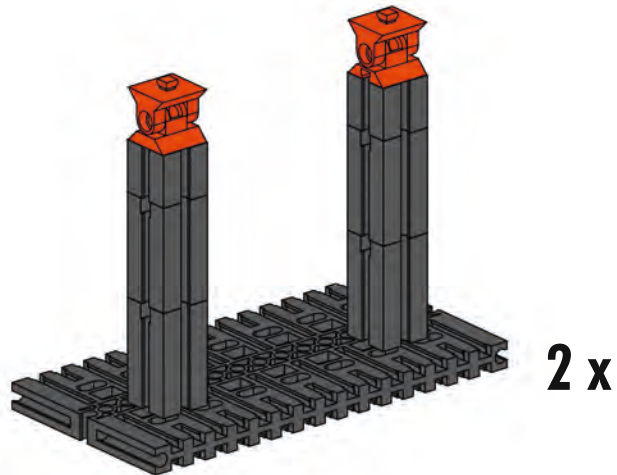

2x      8x  
 4x      4x

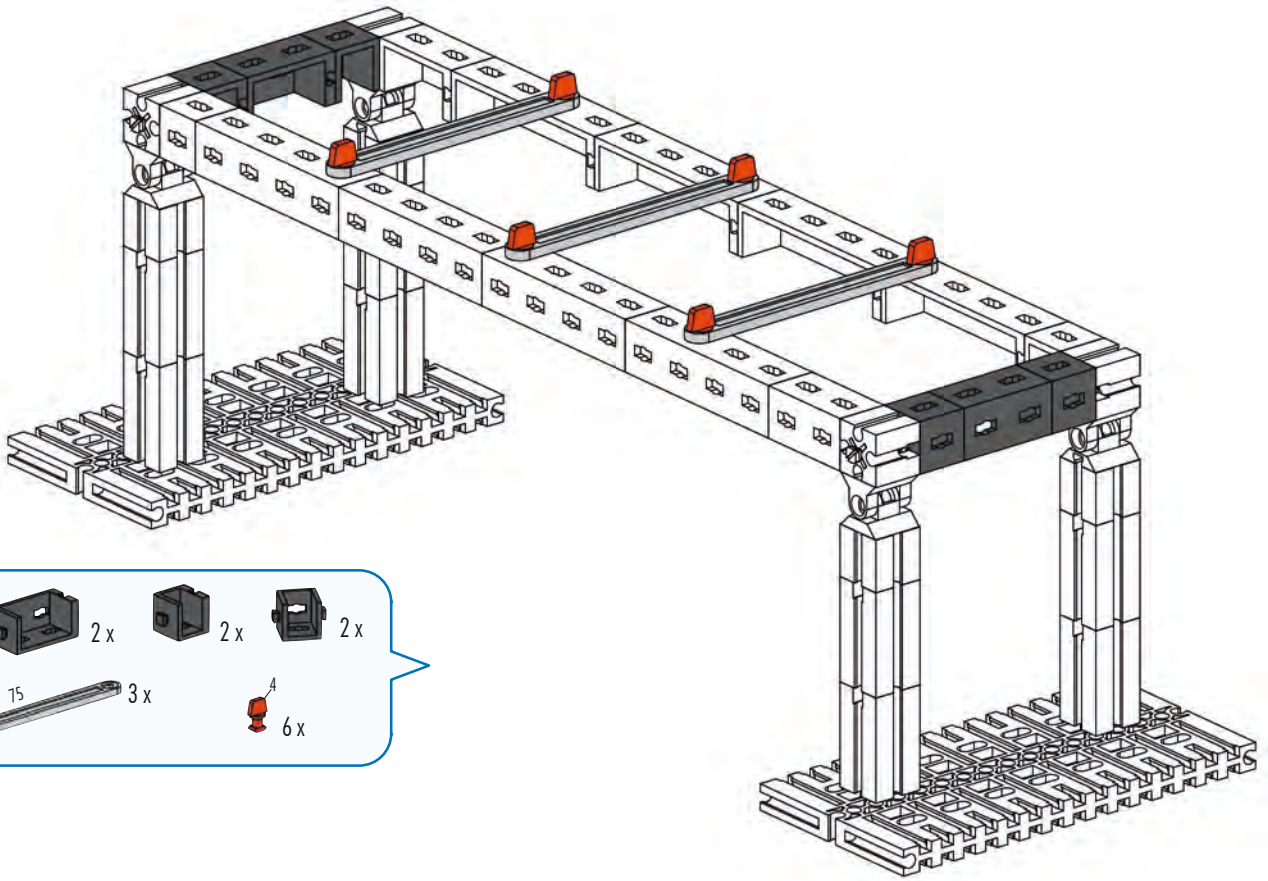

**2**

8x      2x  
 2x      4x



- 3**  2x  2x  2x
-  3x  6x

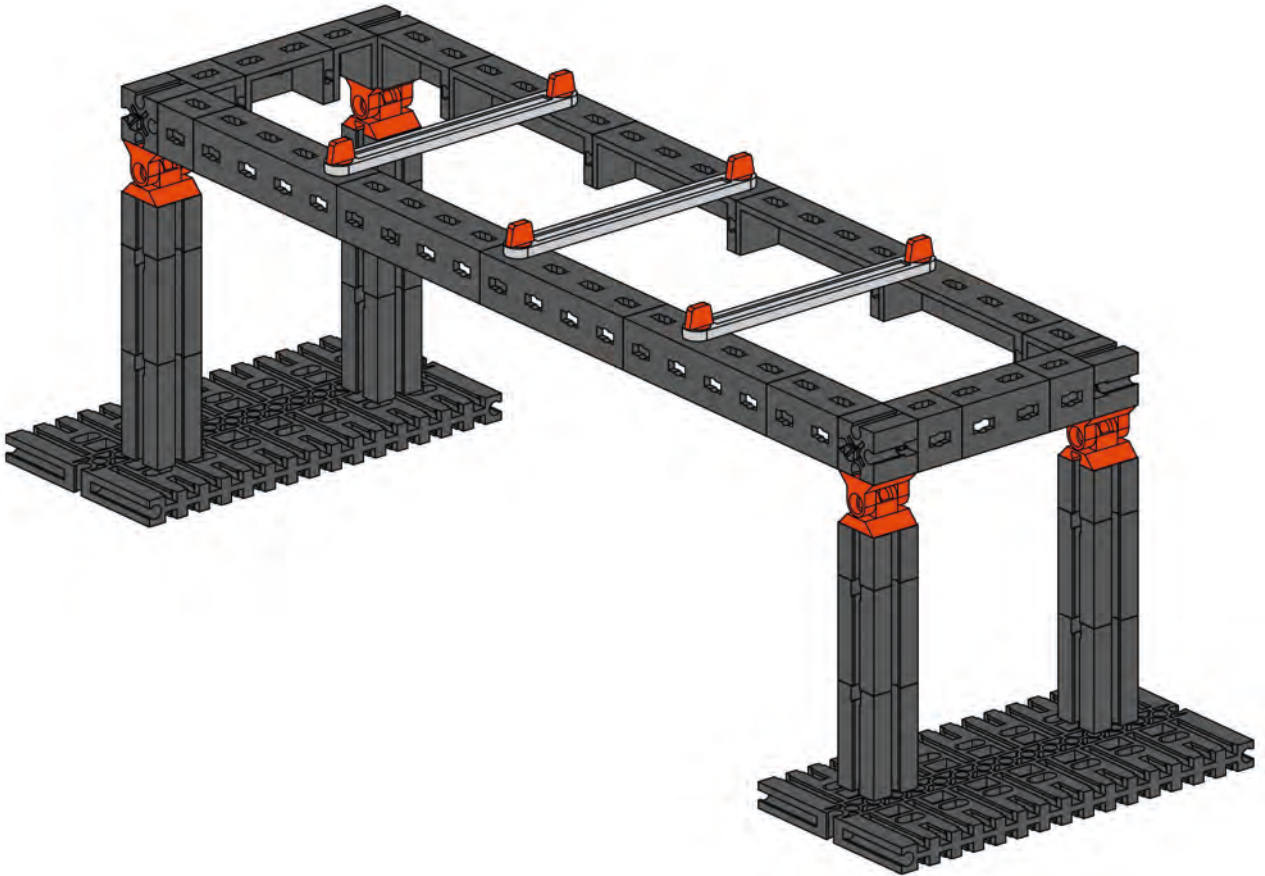



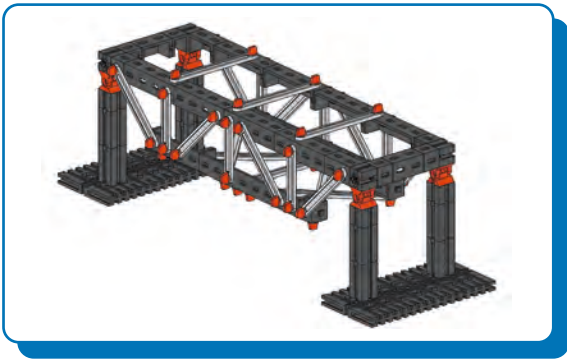

Brücke mit Unterzug  
 Bridge with Underbeam  
 Pont avec  
 solive transversale

Brug met onderlagbalken  
 Puente con viga maestra  
 Ponte com viga de sustentação  
 inferior

Ponte con trave inferiore  
 Мост с нижней рамой  
 带下托梁的桥

# 1-3

Seite 93  
 Page 93  
 Page 93  
 Bladzijde 93  
 Página 93  
 Pagina 93  
 Pagina 93  
 Страница 93  
 页次 93

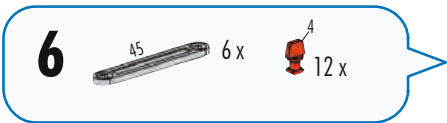
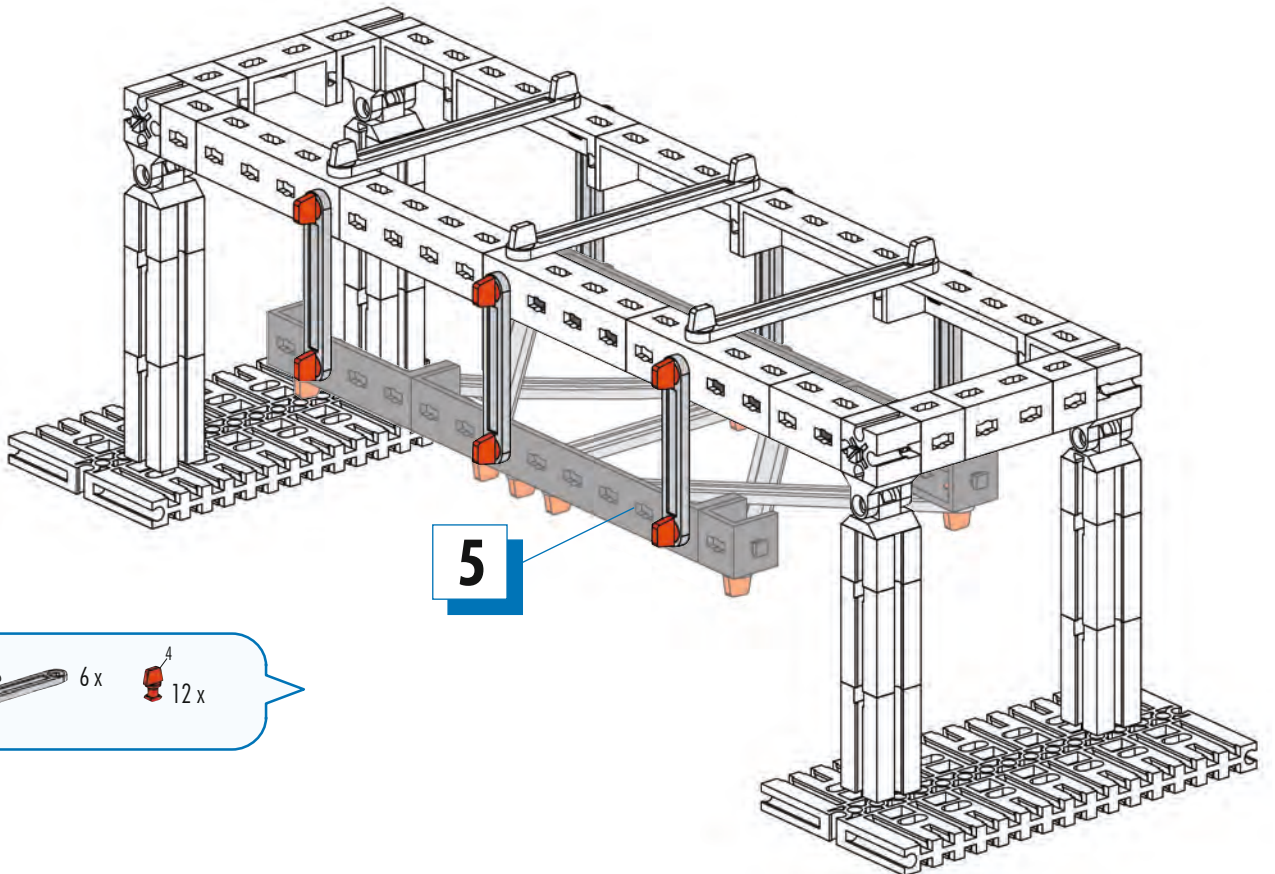
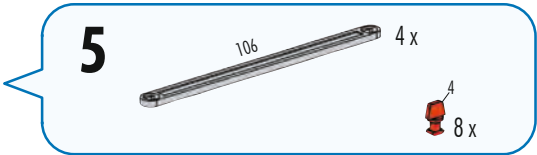
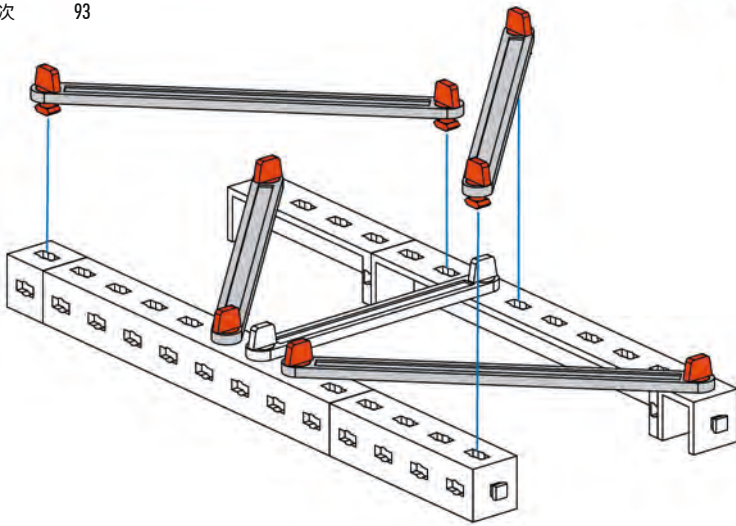
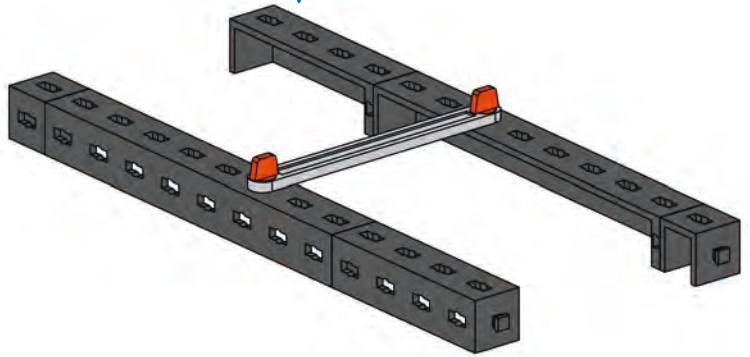
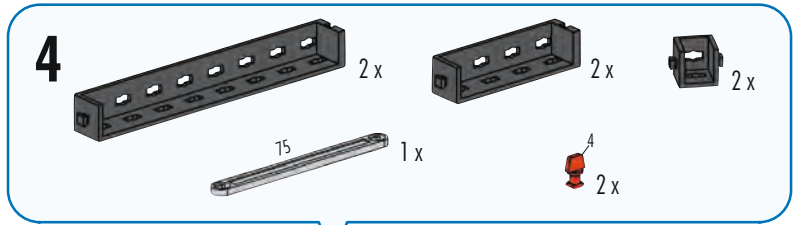

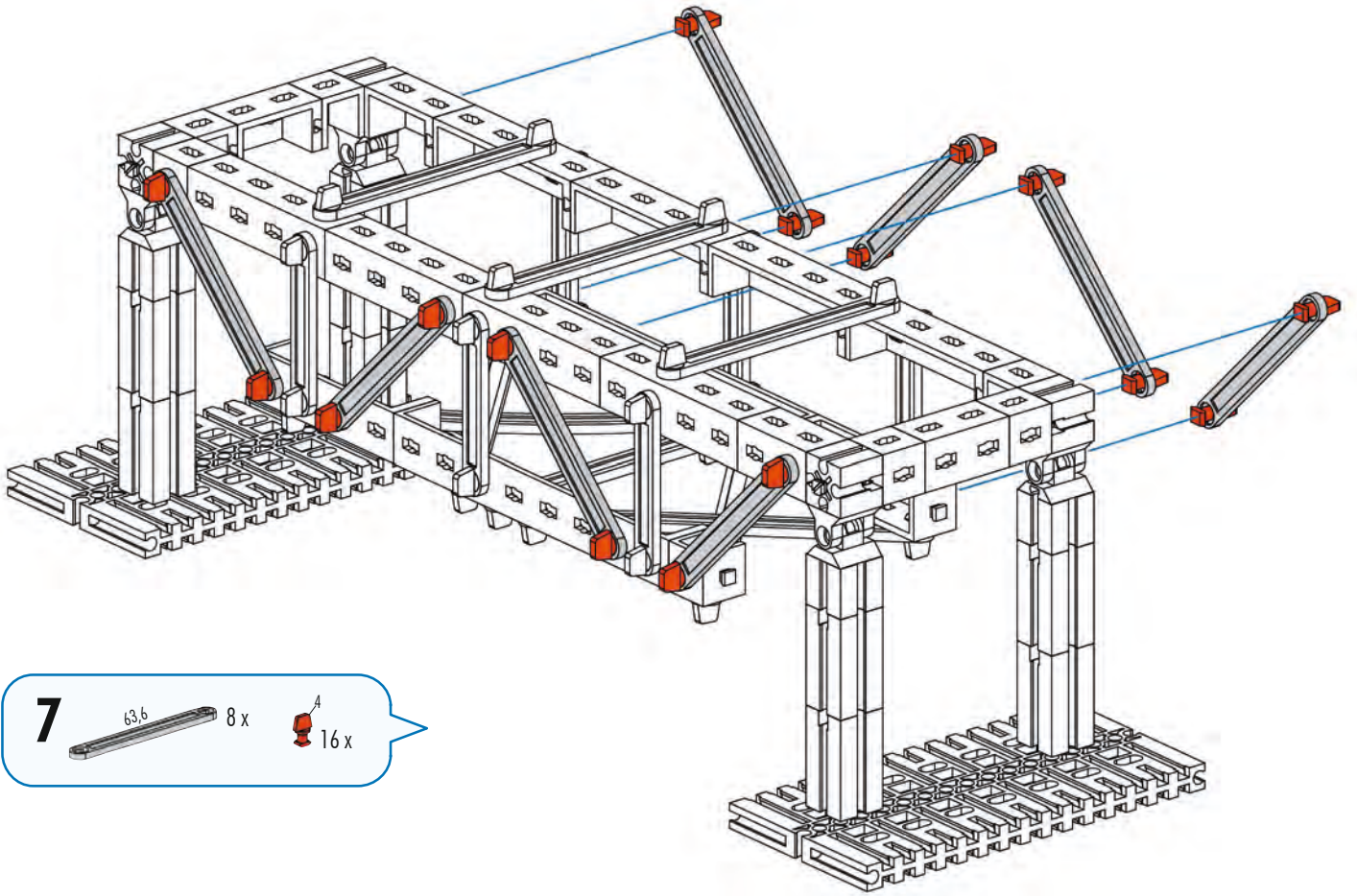

**7** 63,6 8 x  16 x

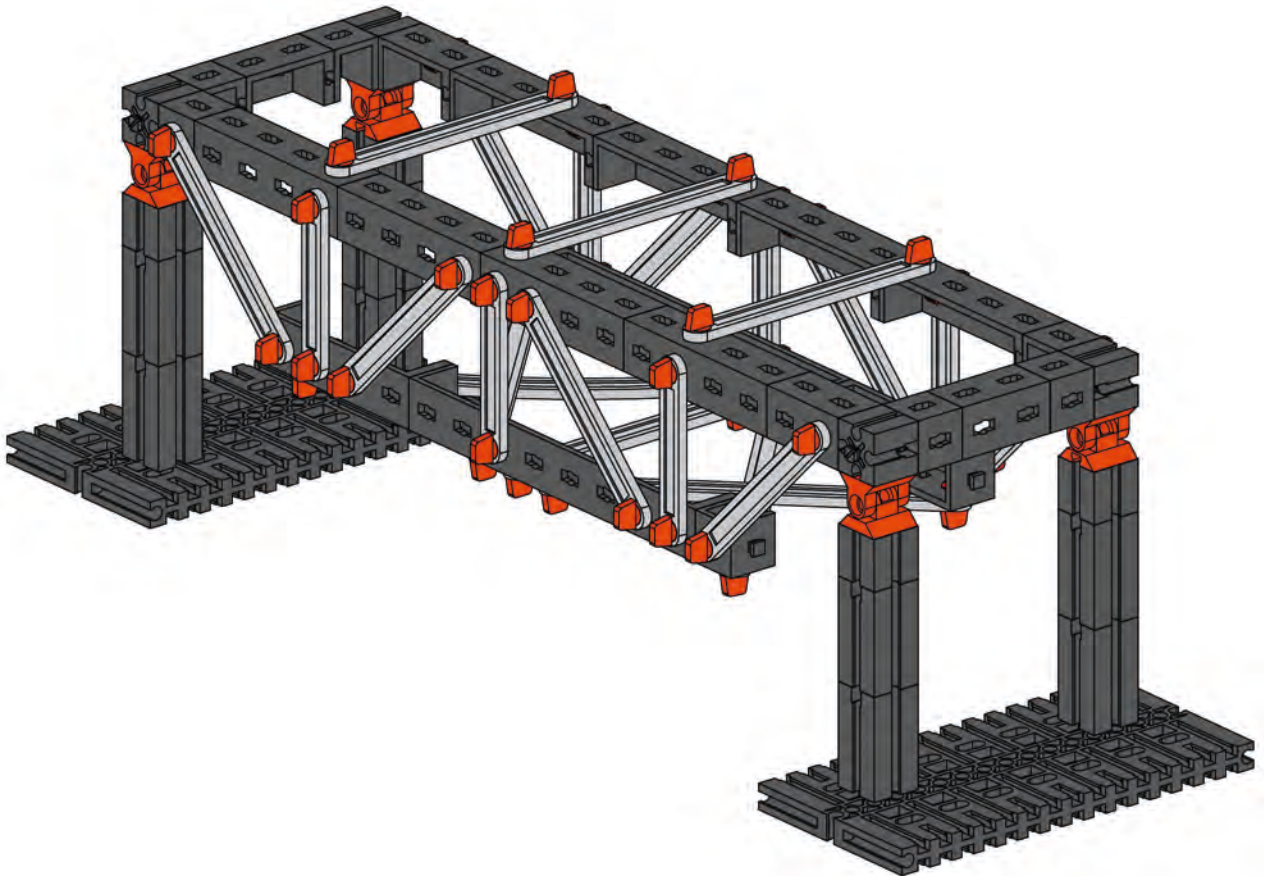



**Brücke mit Oberzug**    **Brug met bovenslagbalken**    **Ponte con trave superiore**  
**Bridge with Upperbeam**    **Puente con viga testera**    **Мост с верхней рамой**  
**Pont à membrure**    **Ponte com viga de**    **带上托梁的桥**  
**supérieure transversale**    **sustentação superior**

**1**

2x    8x  
4x    4x

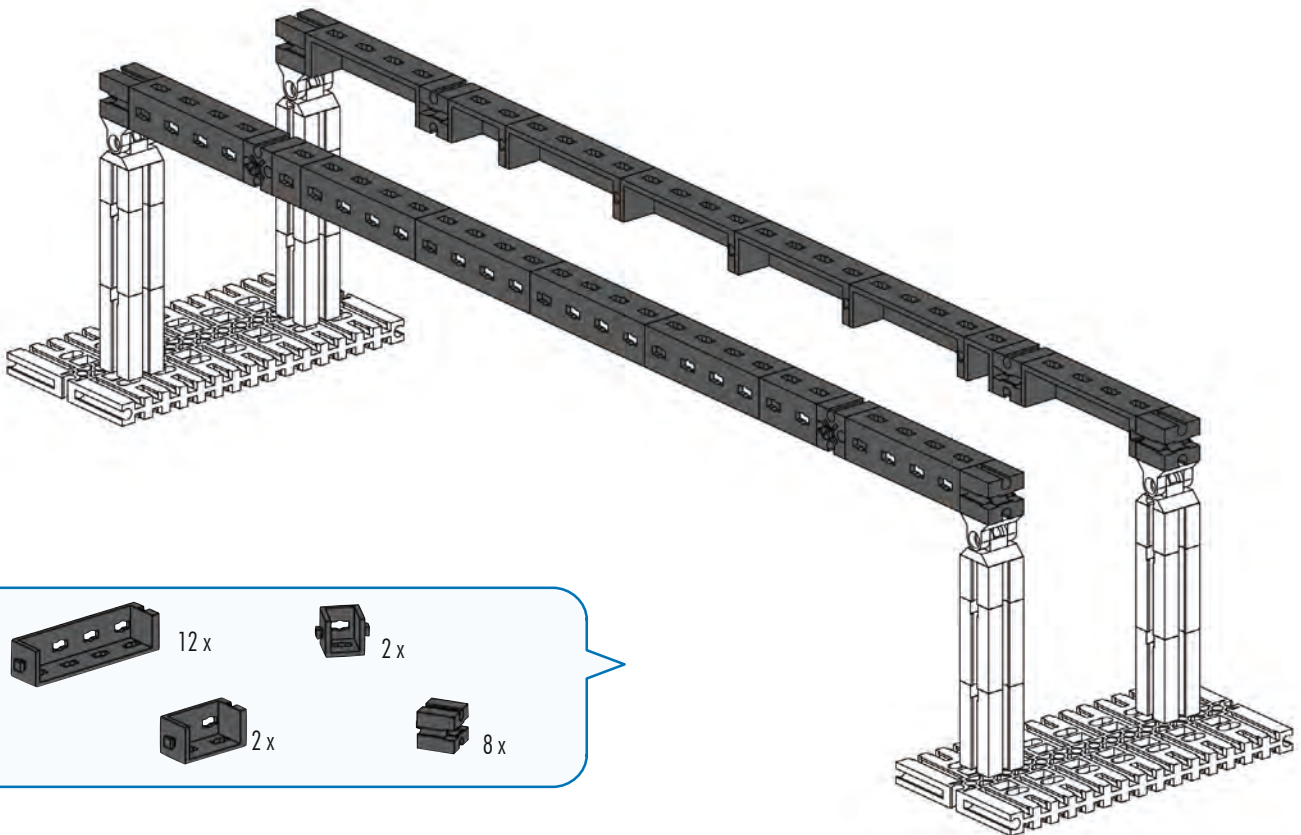
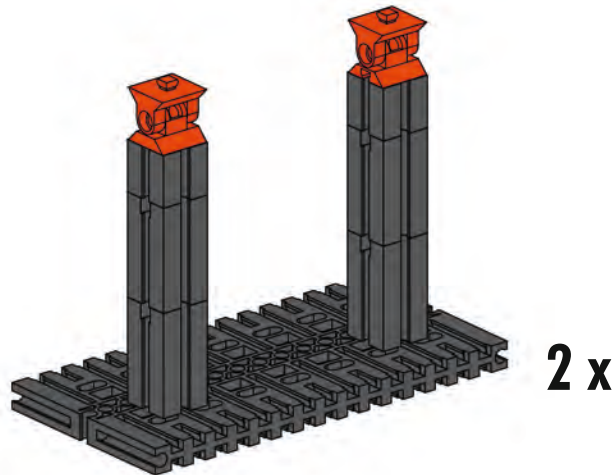

**2**

12x    2x    2x    8x

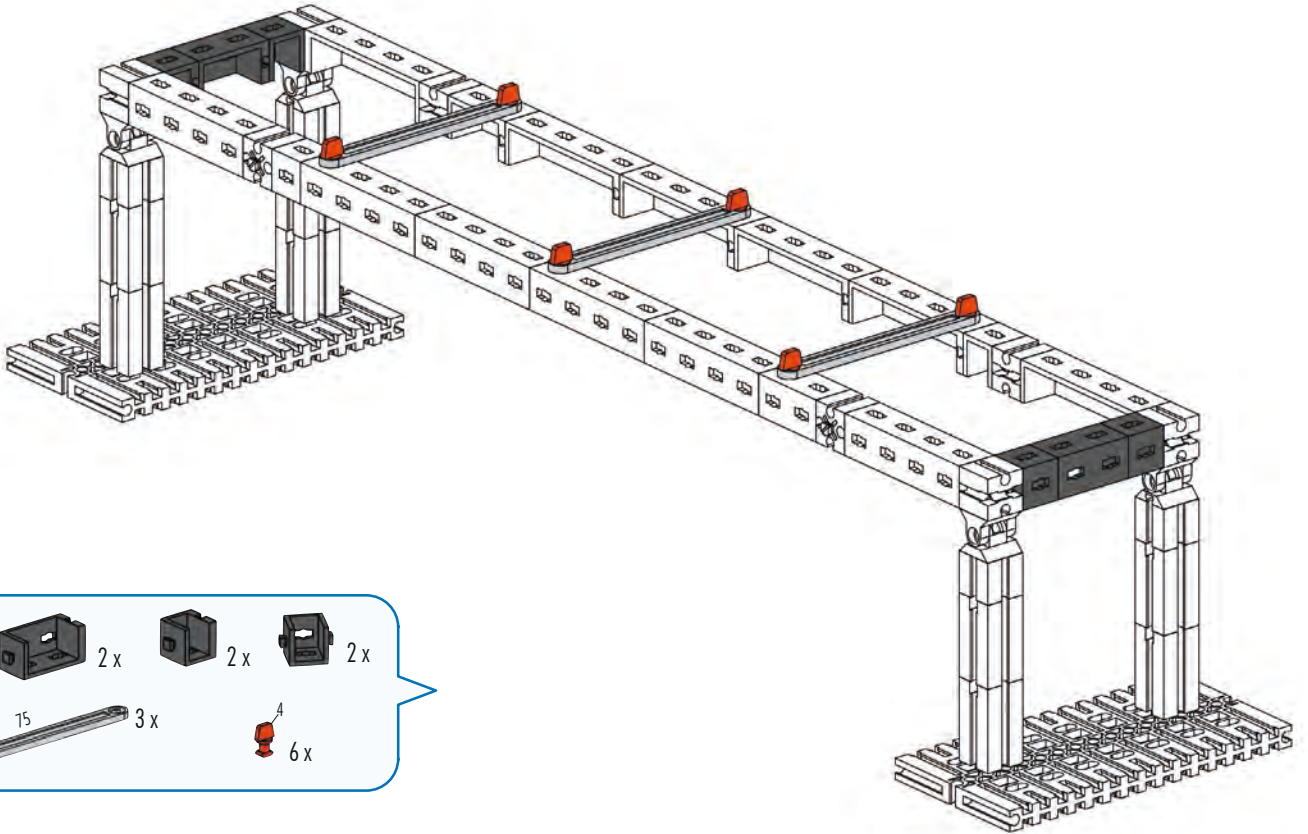

**3**

- 2 x [Small black connector]
- 2 x [Small black connector]
- 2 x [Small black connector]
- 3 x [Long grey axle, labeled 15]
- 6 x [Red pin, labeled A]

**4**

- 4 x [Long black beam]
- 3 x [Long grey axle, labeled 15]
- 2 x [Small black connector]
- 2 x [Small black connector]
- 6 x [Red pin, labeled A]

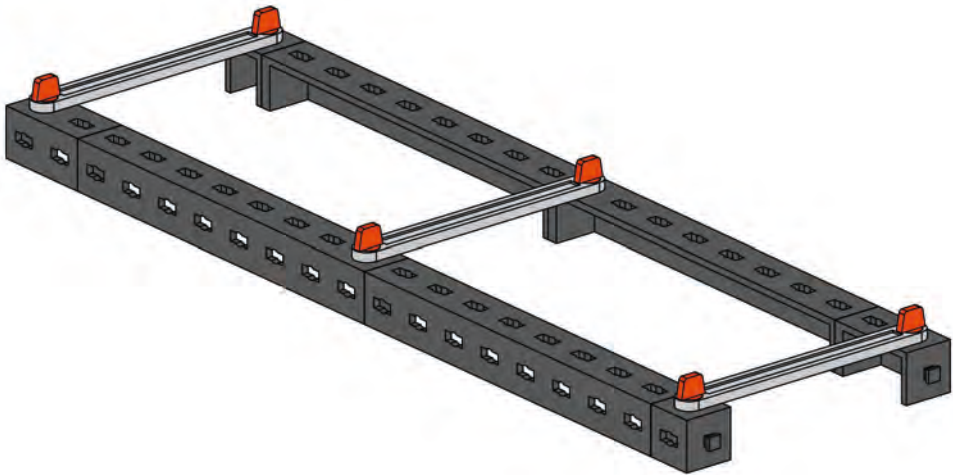

**5** 106 4 x  
 4 8 x

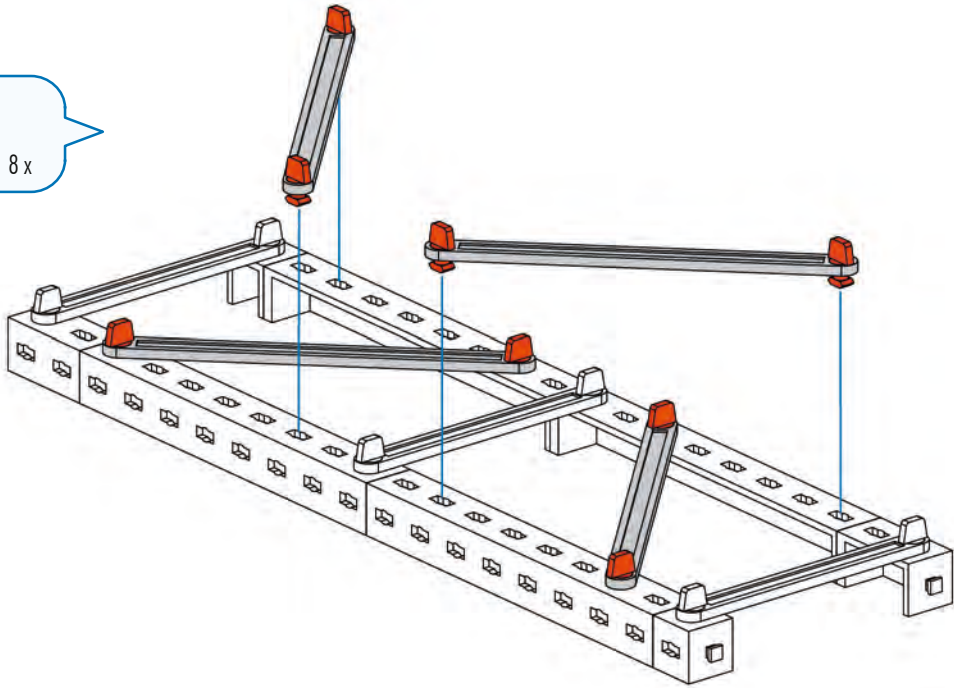

**5**

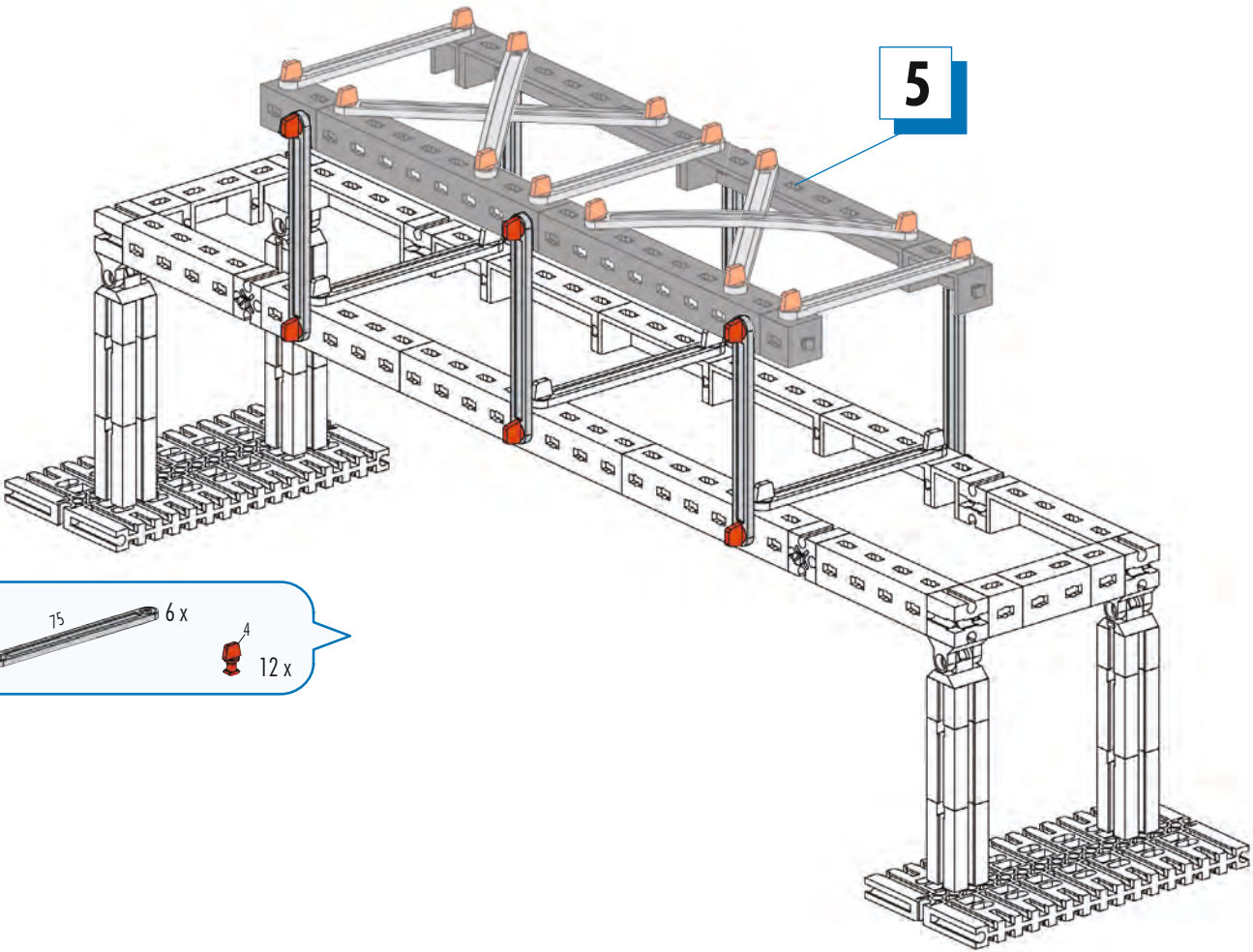

**6** 15 6 x  
 4 12 x

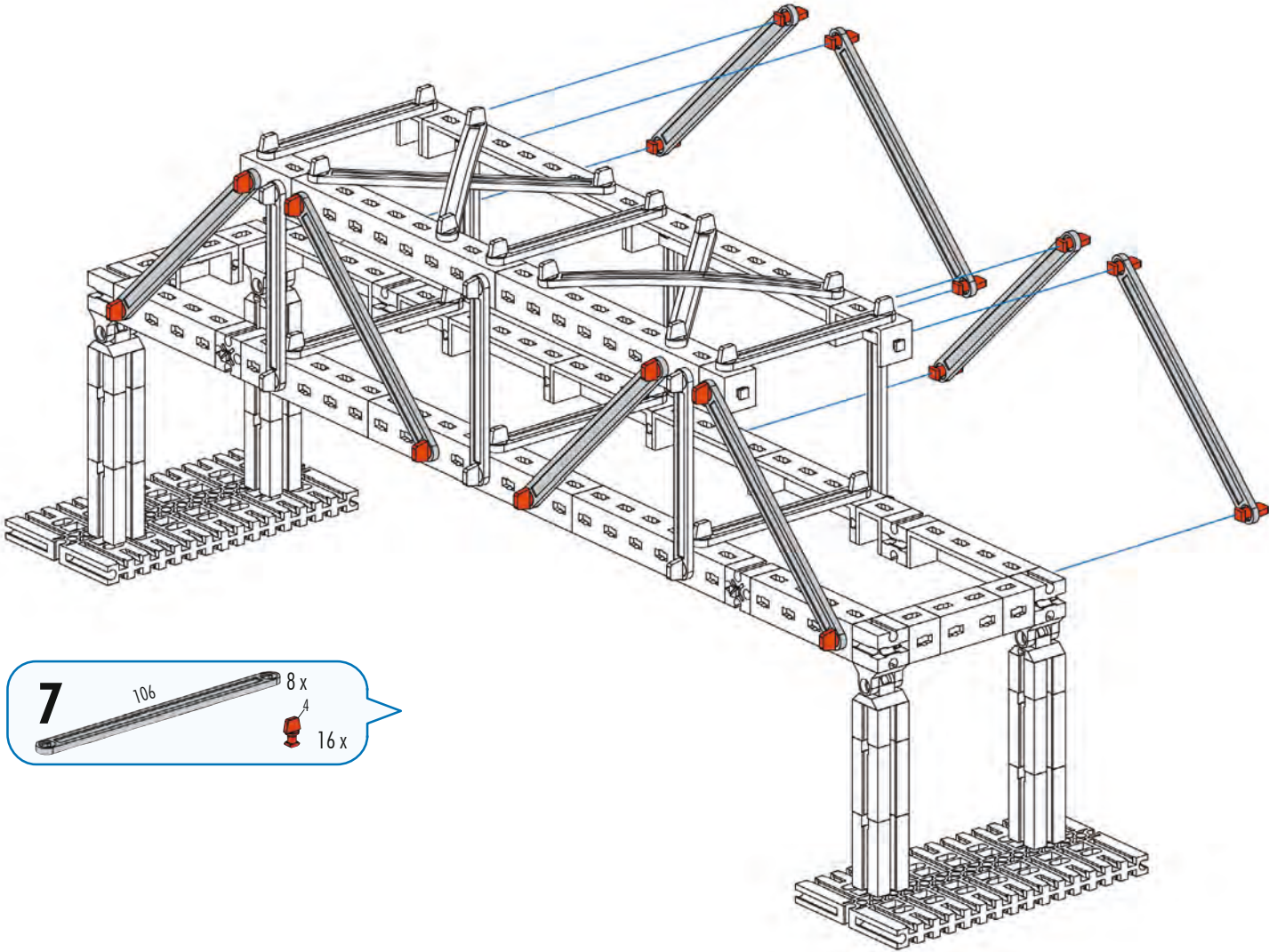

**7** 106 8 x  
4 16 x

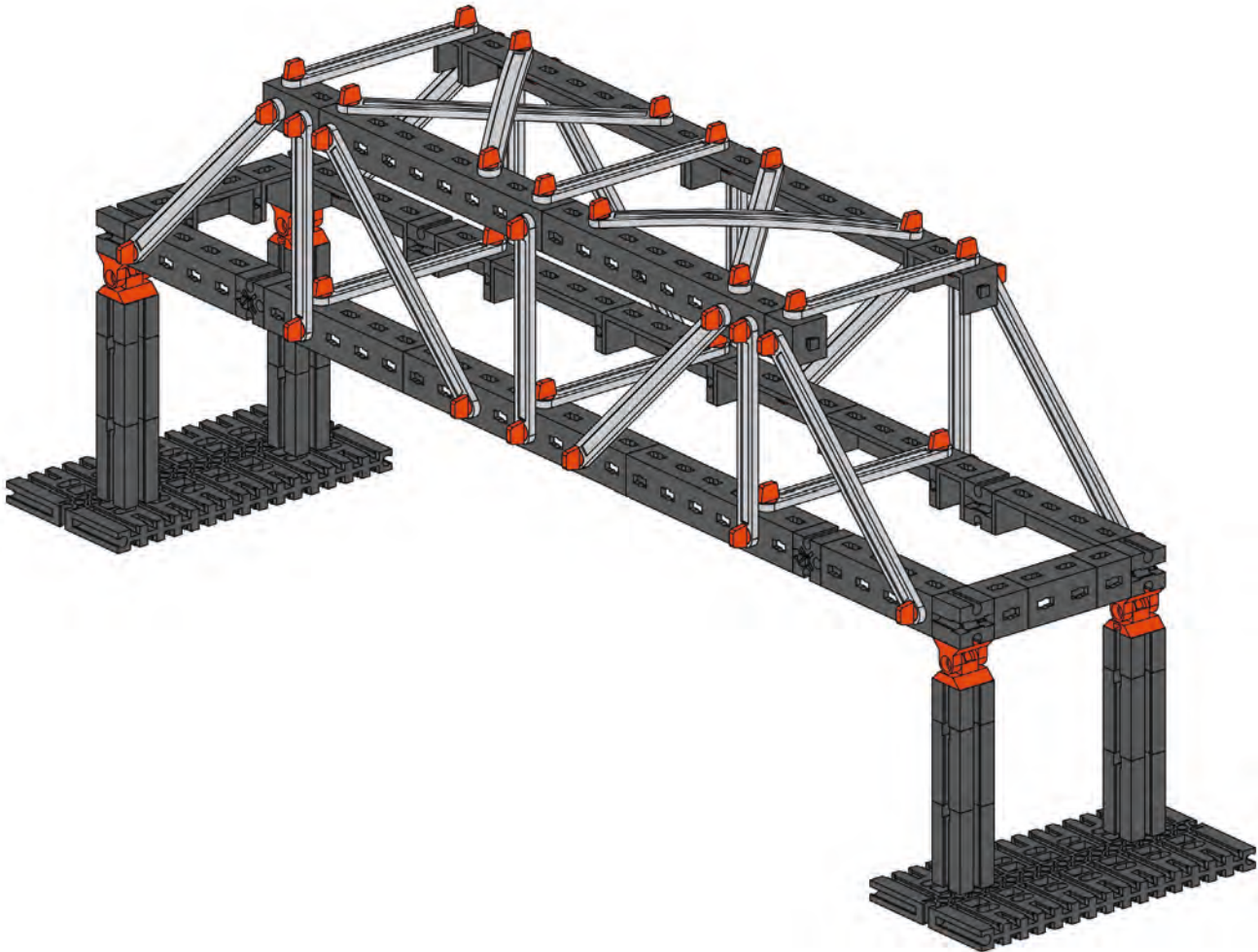



Schrägseilbrücke  
Cable-stayed bridge  
Pont à haubans

Tuibrug  
Puente atirantado  
Ponte estaiada

Ponte con funi di sospensione  
Вантовый мост  
斜拉桥

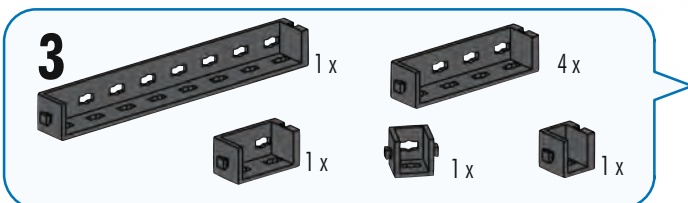
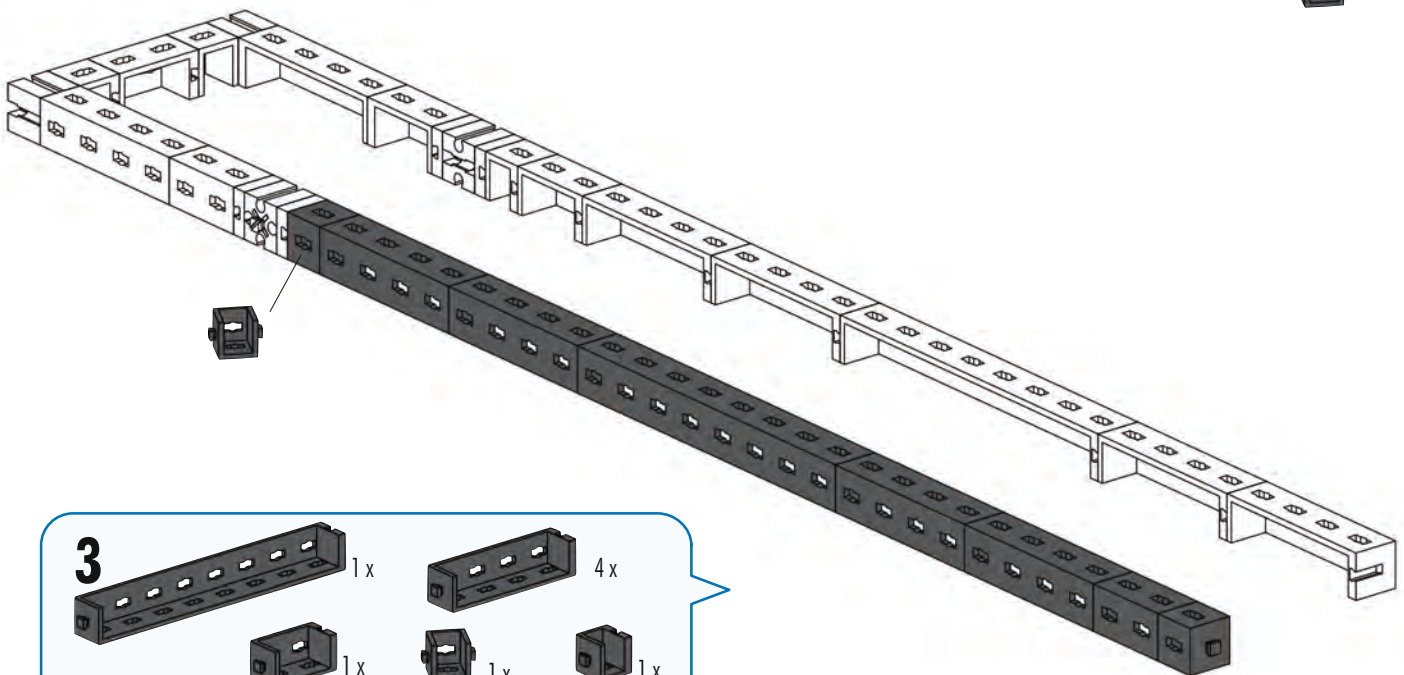
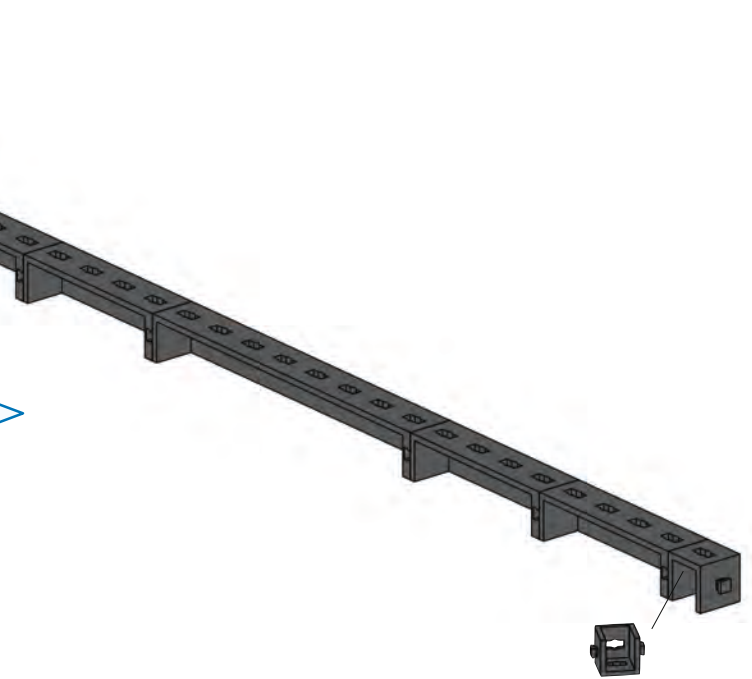
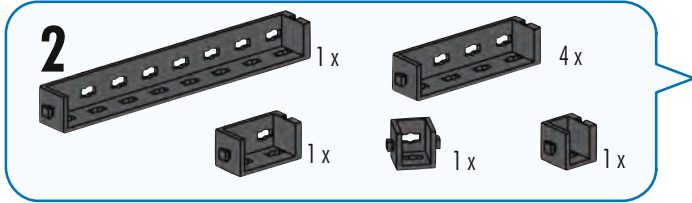
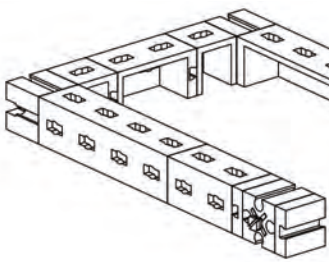
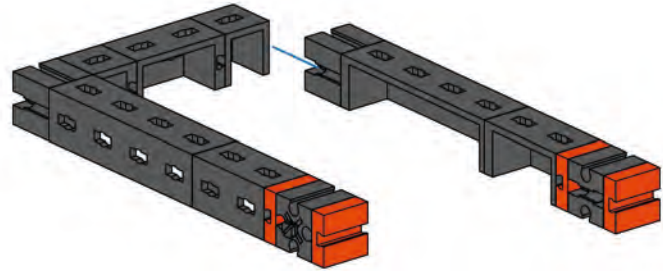
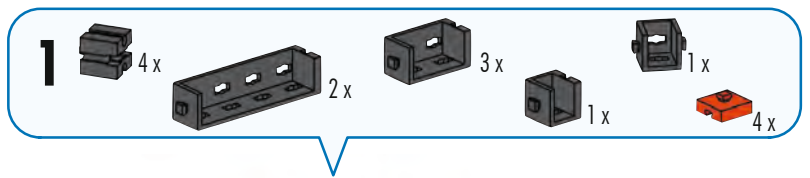

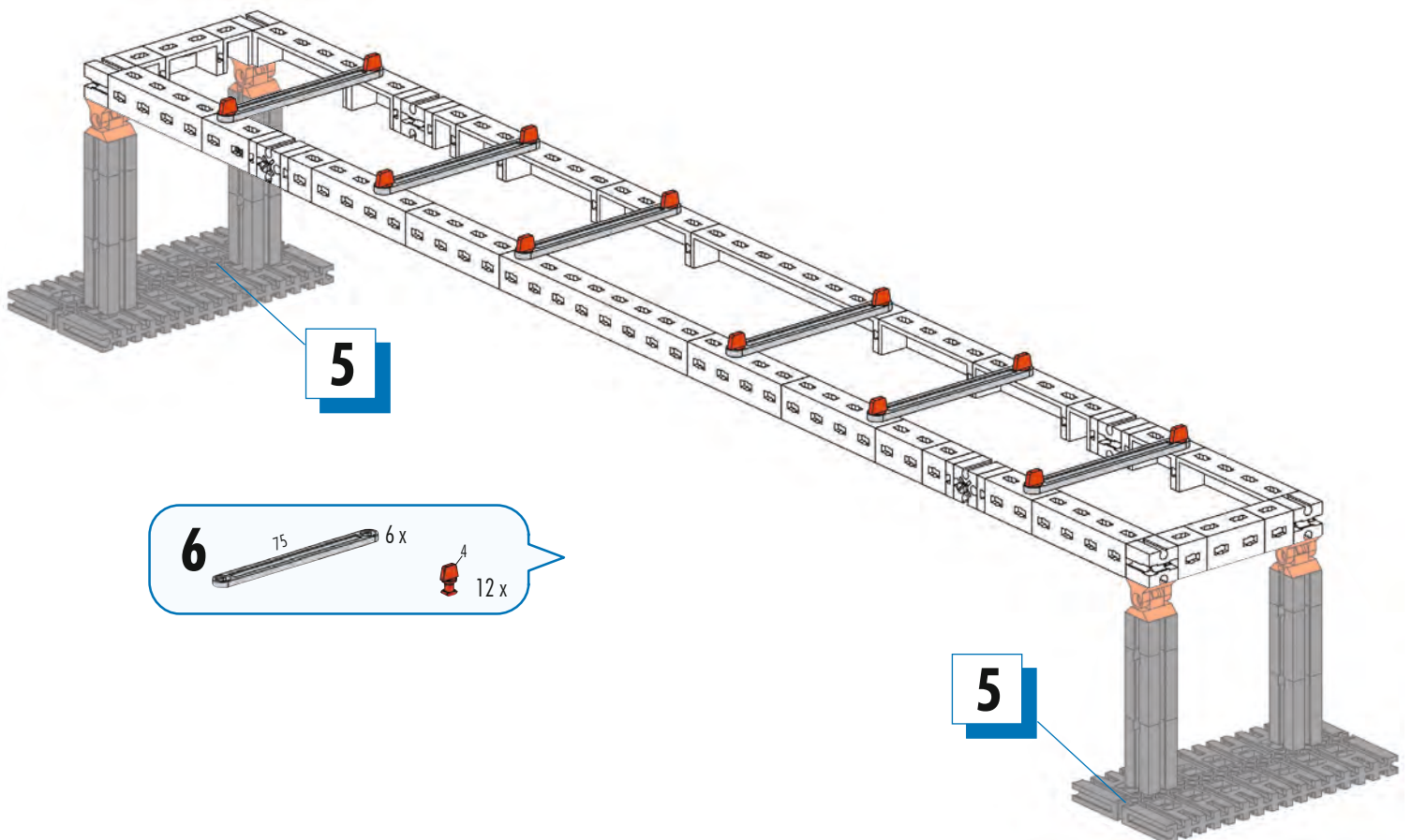
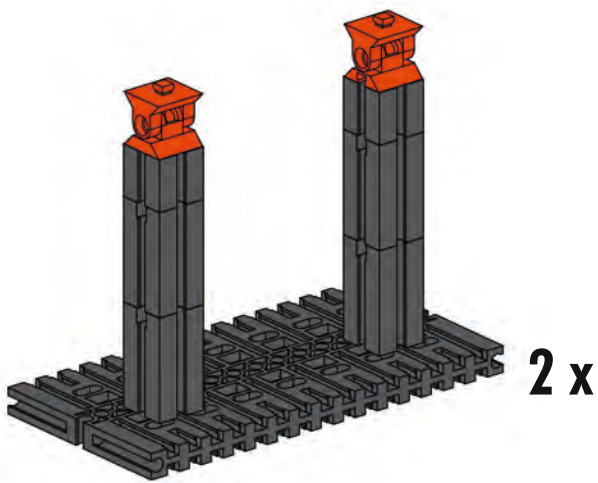
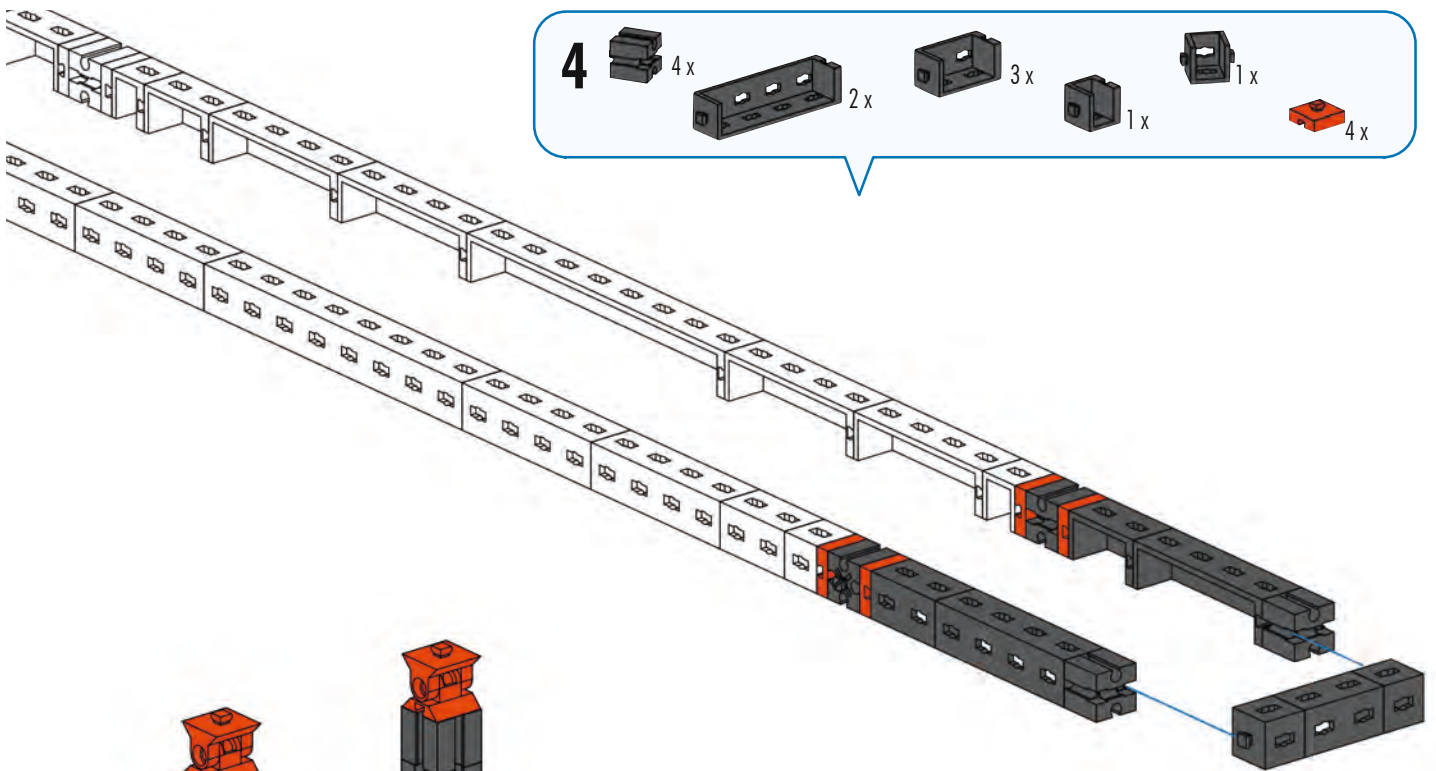



**7**

- 2 x (orange 1x10 Technic beam)
- 5 x (black 1x5 Technic axle)
- 1 x (orange 1x1 Technic pin)
- 2 x (orange 1x2 Technic pin)
- 1 x (orange 1x1 Technic pin)

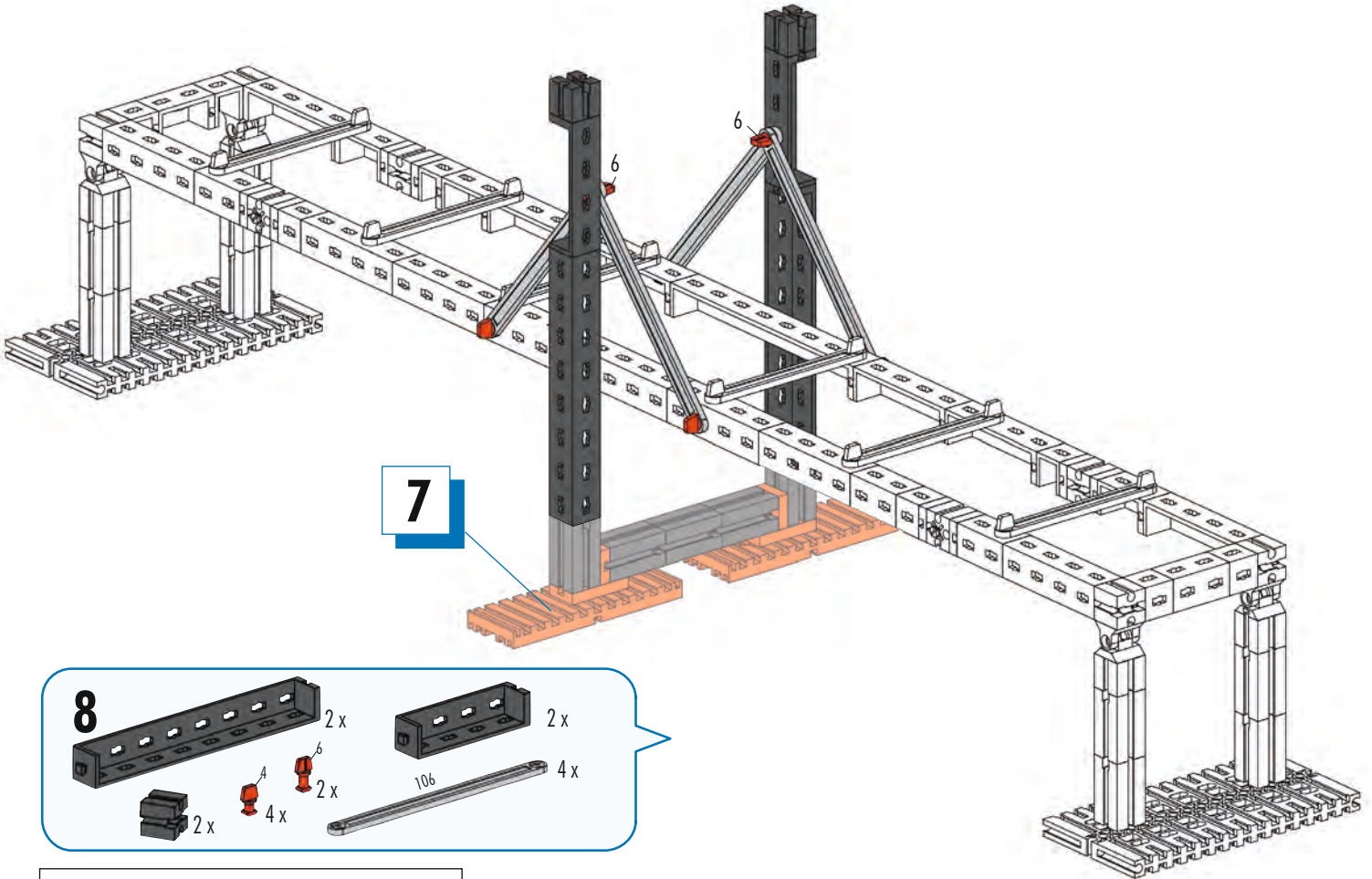
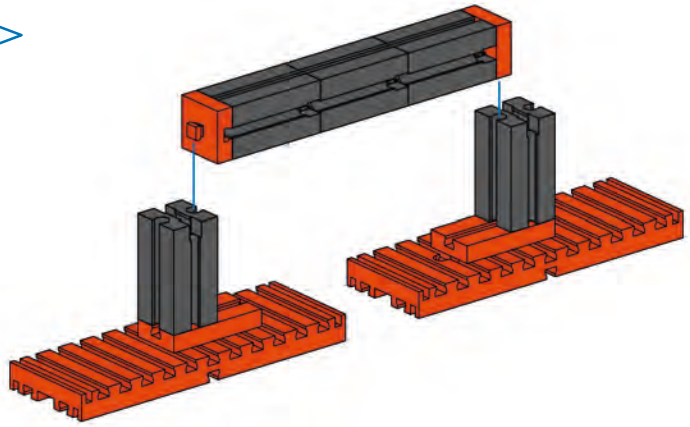

**8**

- 2 x (black 1x10 Technic axle)
- 2 x (black 1x5 Technic axle)
- 4 x (red 1x4 Technic pin)
- 2 x (red 1x2 Technic pin)
- 4 x (grey 1x10 Technic axle)

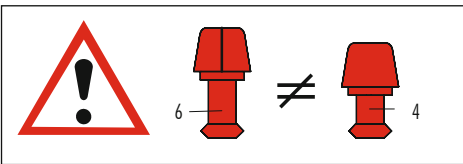

**9**

- 4 x (grey 1x10 Technic axle, labeled 106)
- 4 x (grey 1x10 Technic axle, labeled 63.6)
- 4 x (orange 1x4 Technic pin)
- 8 x (red 1x2 Technic pin)

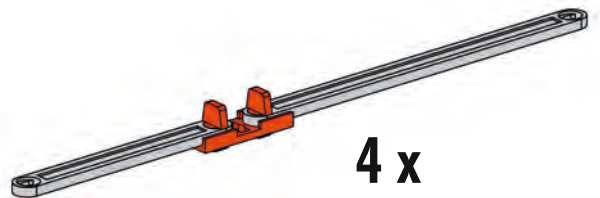

**10**

- 106 4 x
- 63,6 8 x
- 30 4 x
- 15 4 x
- 4 16 x

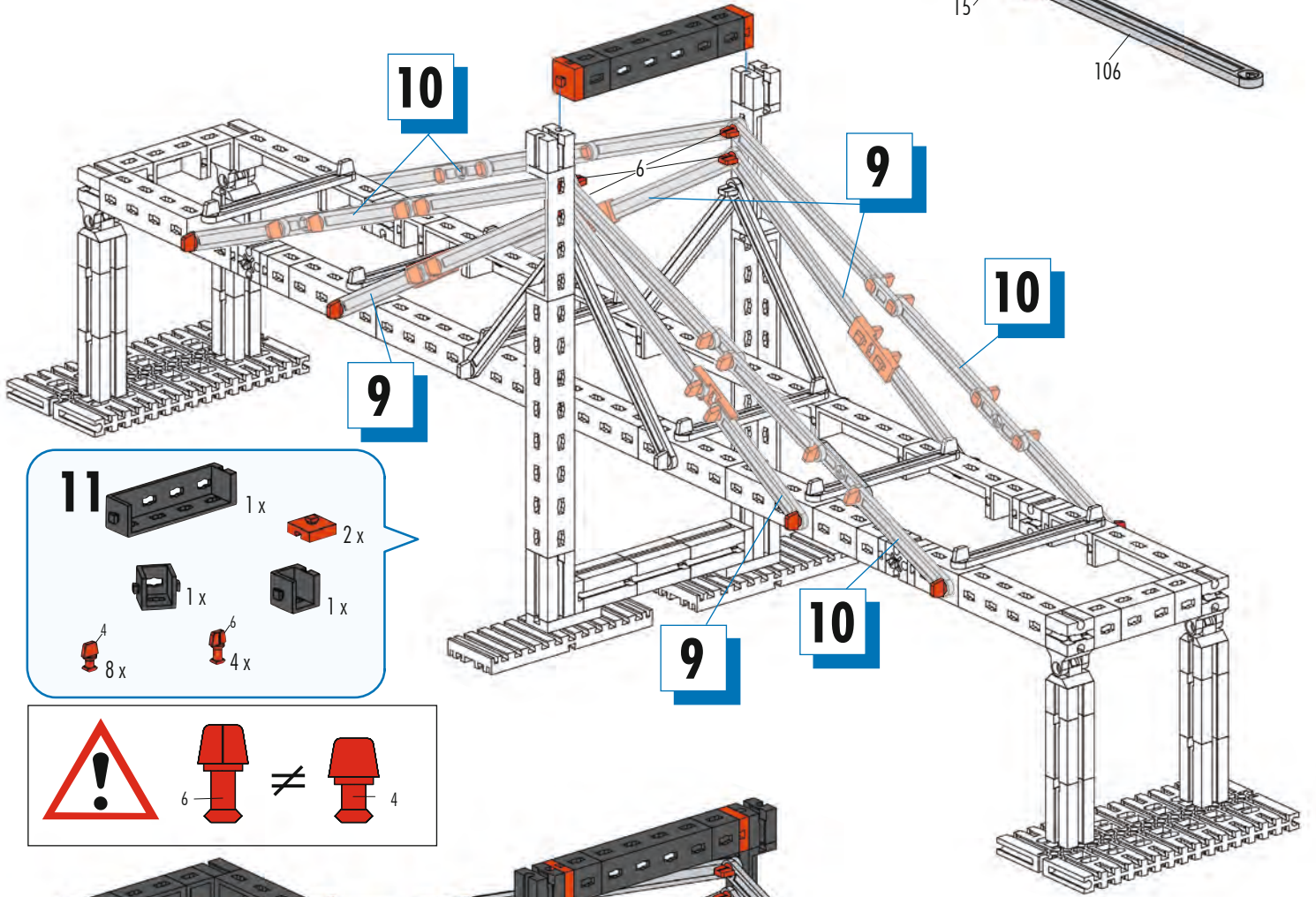
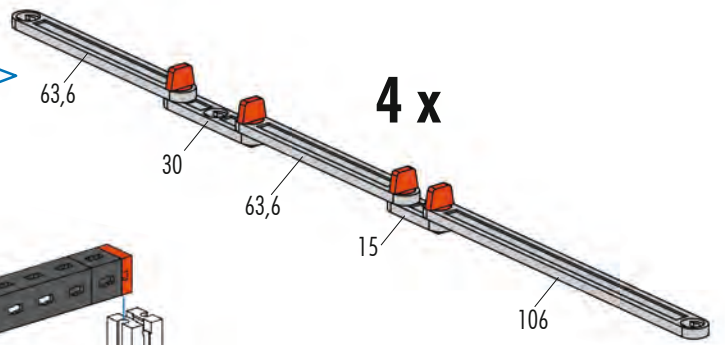

**11**

- 1 x
- 2 x
- 1 x
- 1 x
- 8 x
- 4 x

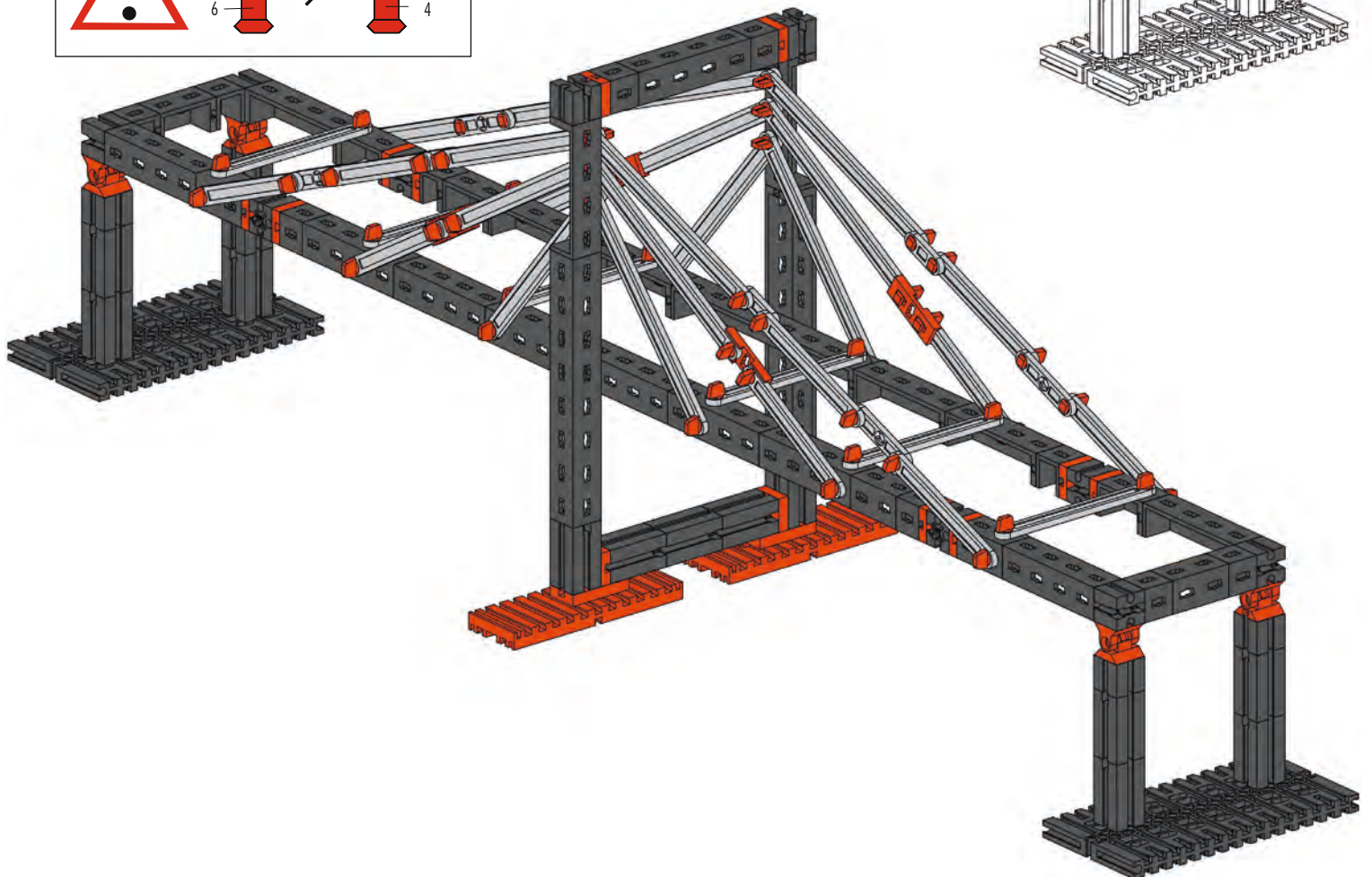
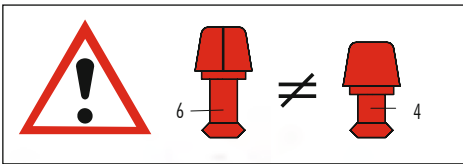





Kran  
Crane  
Grue

Kraan  
Grúa  
Guindaste

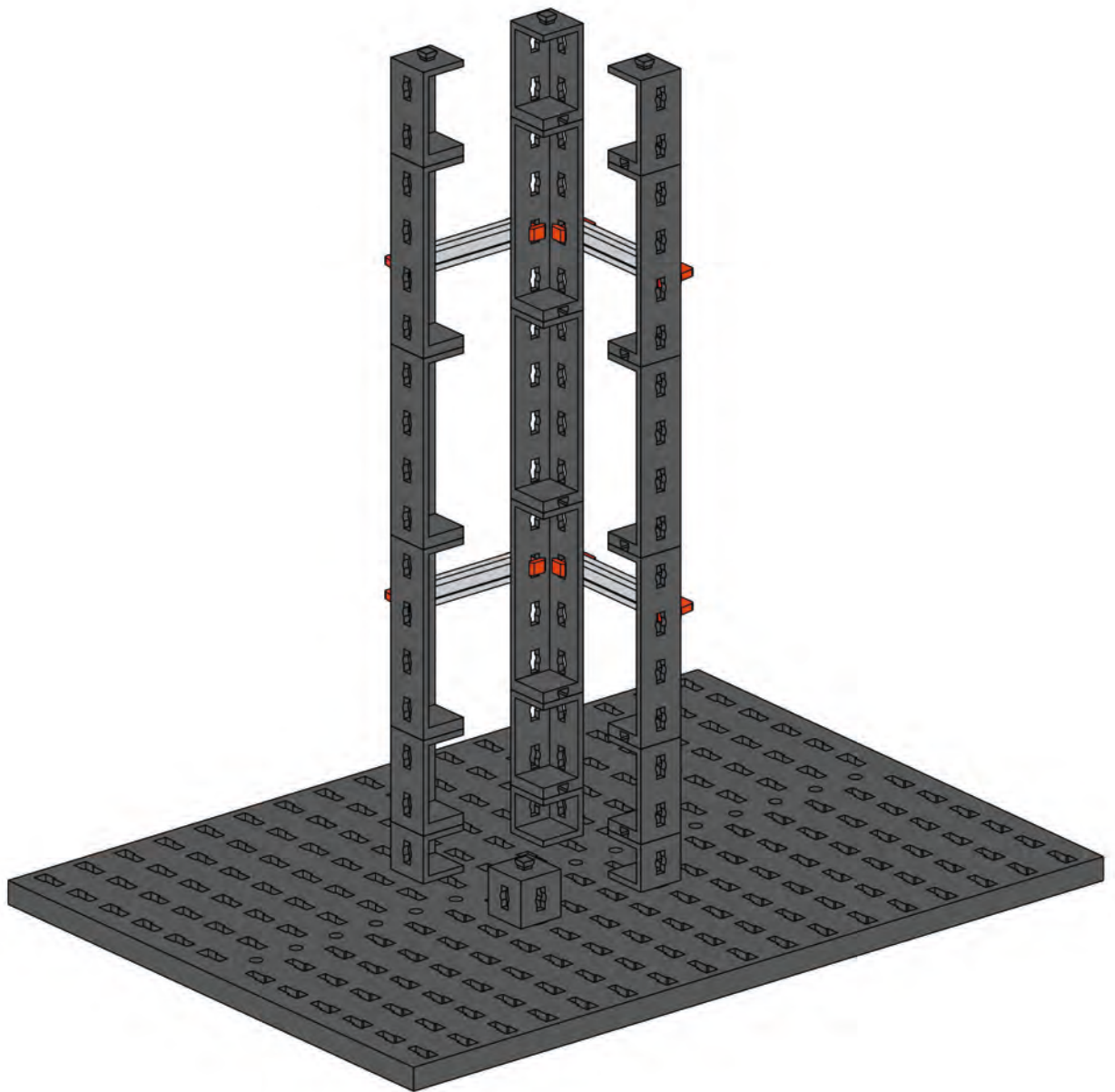
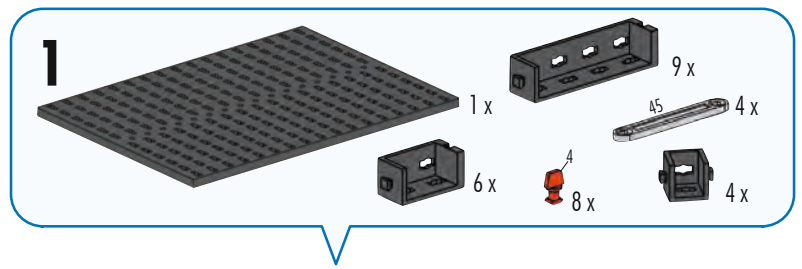
Gru  
Кран  
起重机

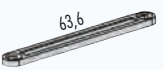

**2**  3 x  12 x  6 x

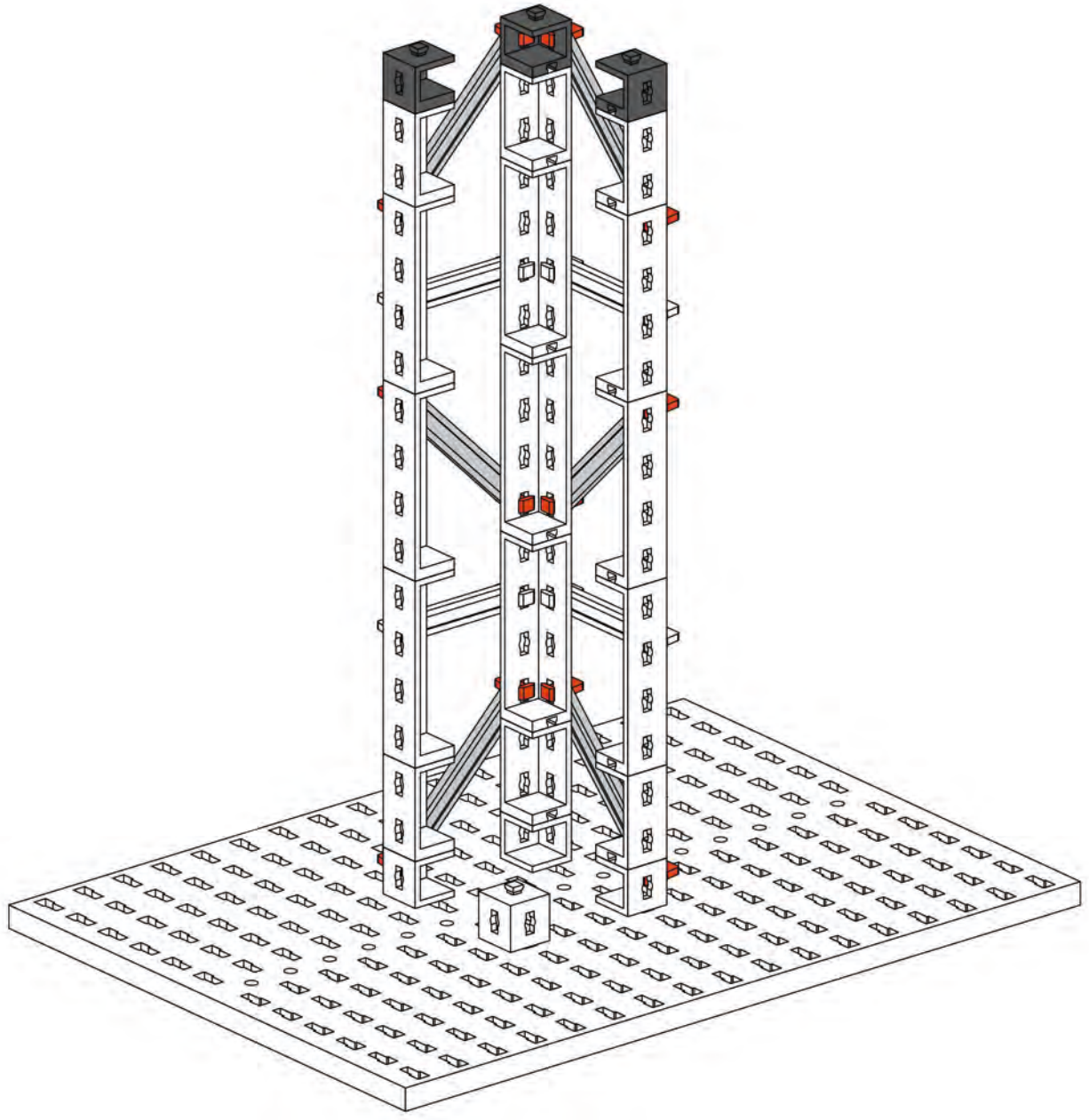

**3**

- 3 x [Black 1x3 Technic Beam]
- 2 x [Black 1x2 Technic Beam]
- 1 x [Black 1x1 Technic Beam]
- 4 x [Grey Technic Pin]
- 8 x [Red Technic Pin]

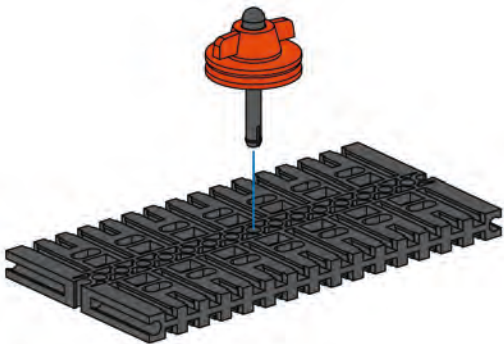
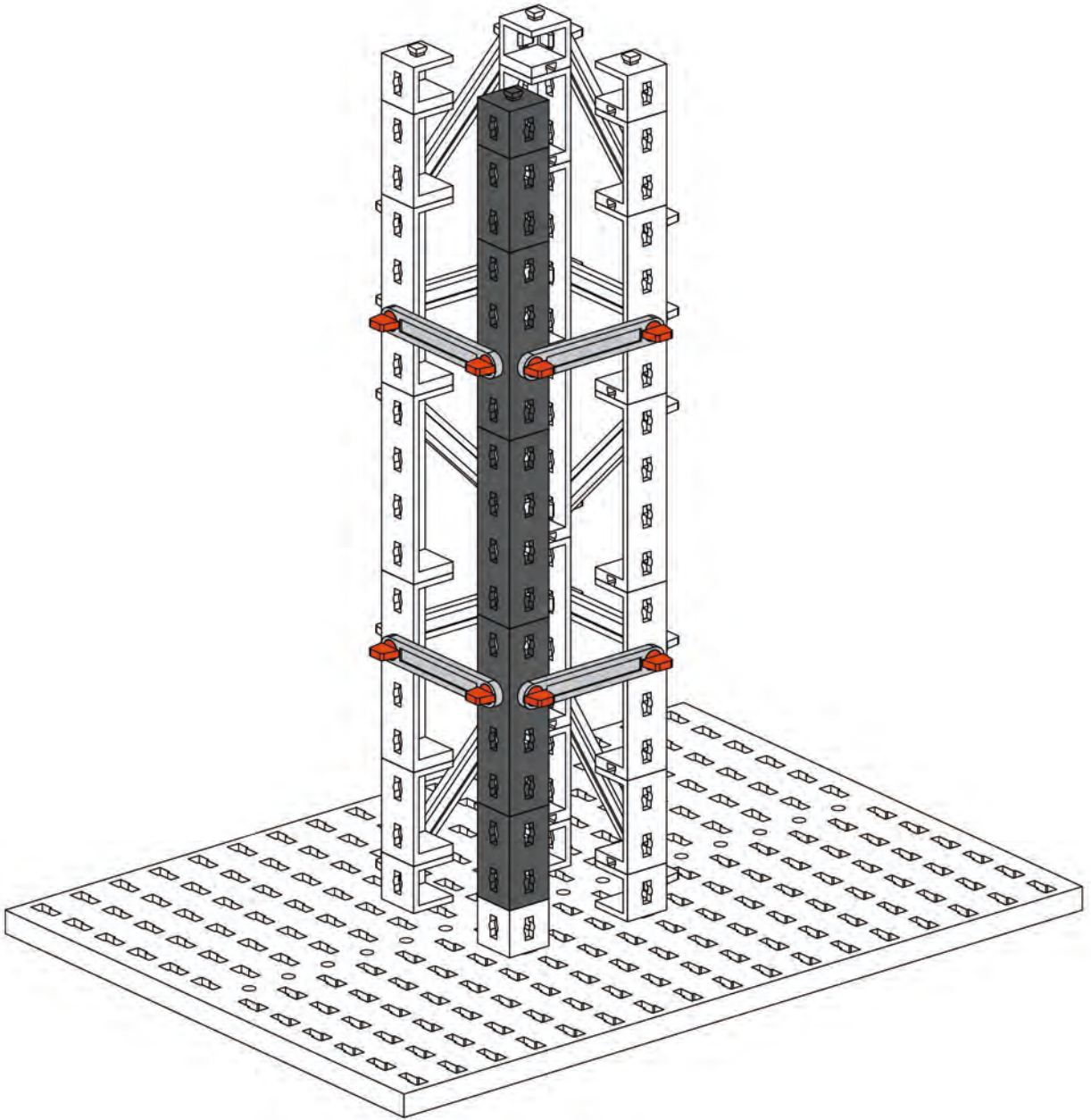

**4**

- 1 x [Black 1x10 Technic Beam]
- 1 x [Red Technic Pin]
- 1 x [Red Technic Pin]
- 1 x [Grey Technic Pin]

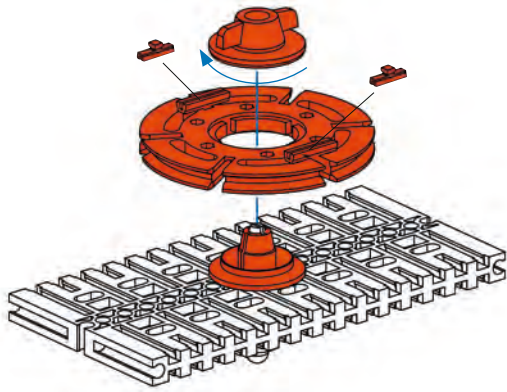

**5**

- 1 x
- 1 x
- 1 x
- 2 x

**6**

- 4 x

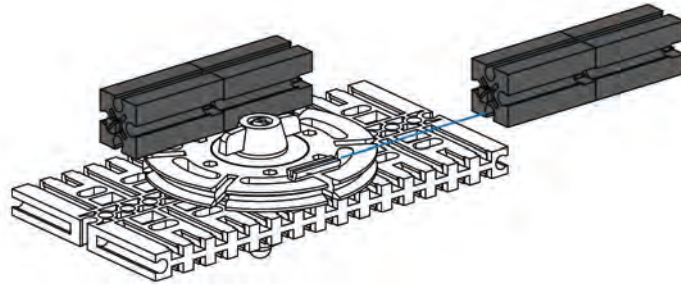

**6**

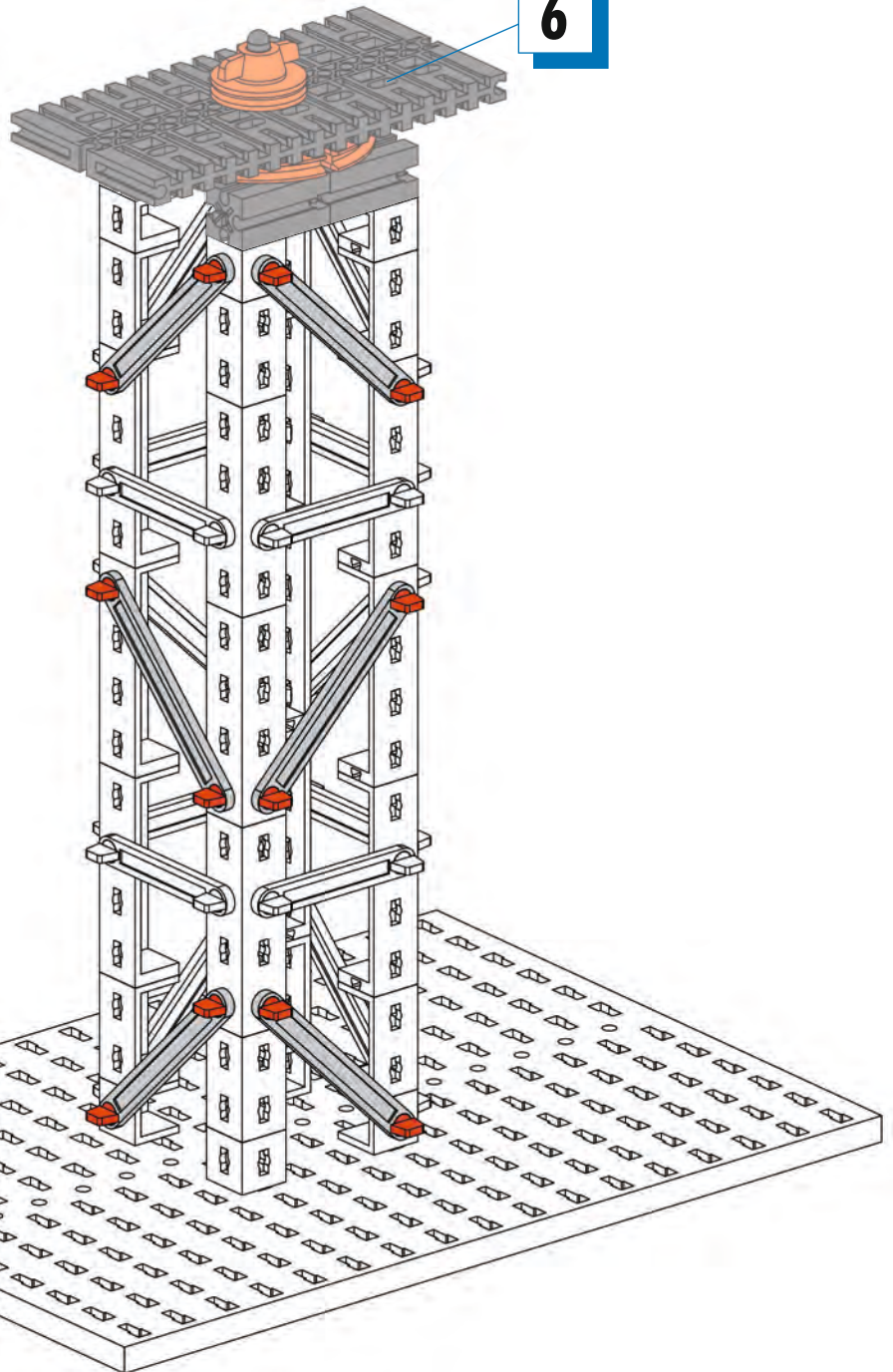

**7**

- 12 x
- 6 x

- 8**
- 4 x [1x1 orange Technic brick]
  - 1 x [1x3 orange Technic L-shaped Technic brick]
  - 1 x [grey Technic axle]
  - 3 x [1x2 orange Technic brick with hole]
  - 1 x [60° orange Technic wedge]
  - 1 x [1x2 orange Technic Technic brick]
  - 1 x [30 orange Technic Technic brick]
  - 1 x [30 grey Technic axle]
  - 1 x [grey Technic axle pin]

30 mm

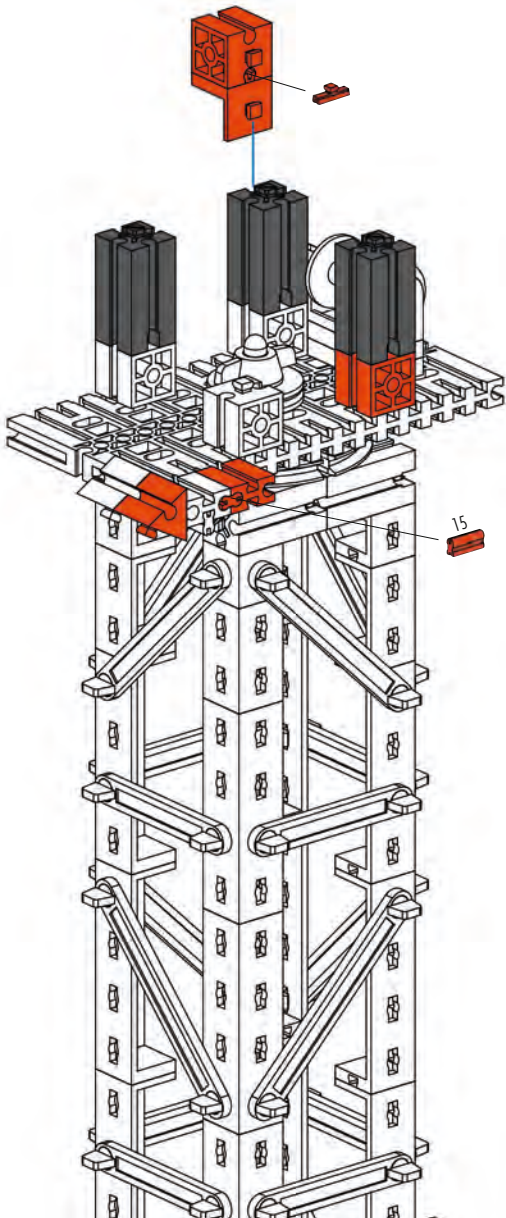
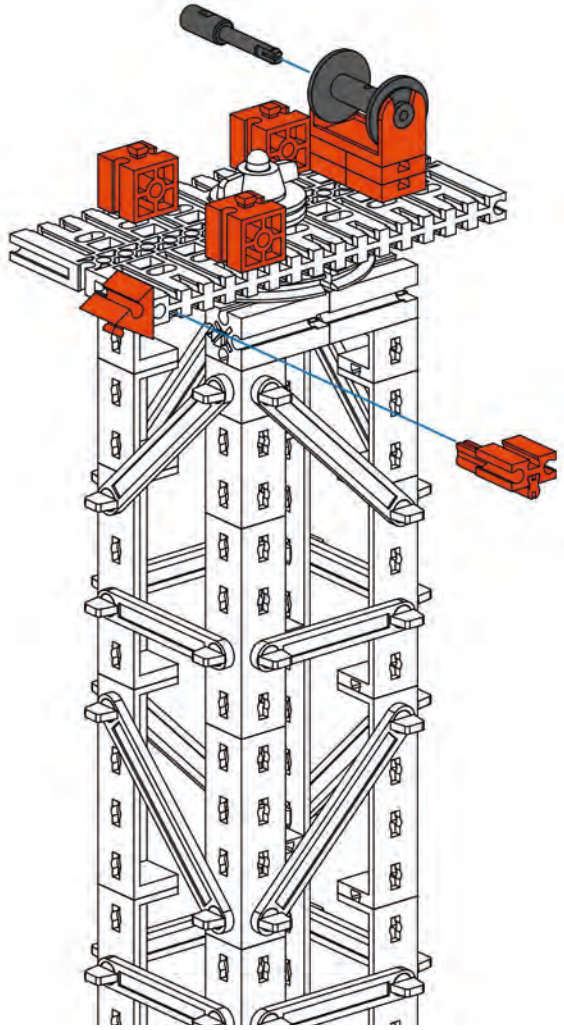

- 9**
- 3 x [grey Technic Technic brick]
  - 2 x [1x2 orange Technic brick with hole]
  - 1 x [60° orange Technic wedge]
  - 1 x [1x3 orange Technic L-shaped Technic brick]
  - 1 x [1x2 orange Technic Technic brick]
  - 1 x [15 orange Technic Technic brick]
  - 1 x [red Technic axle pin]

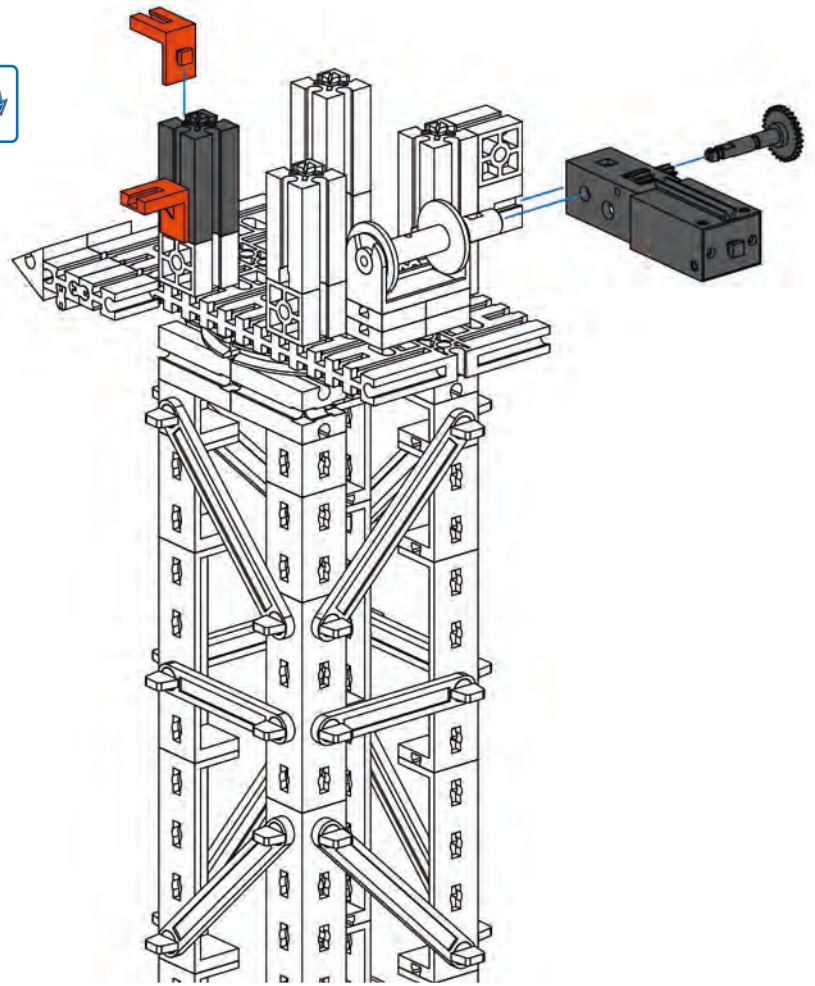

10

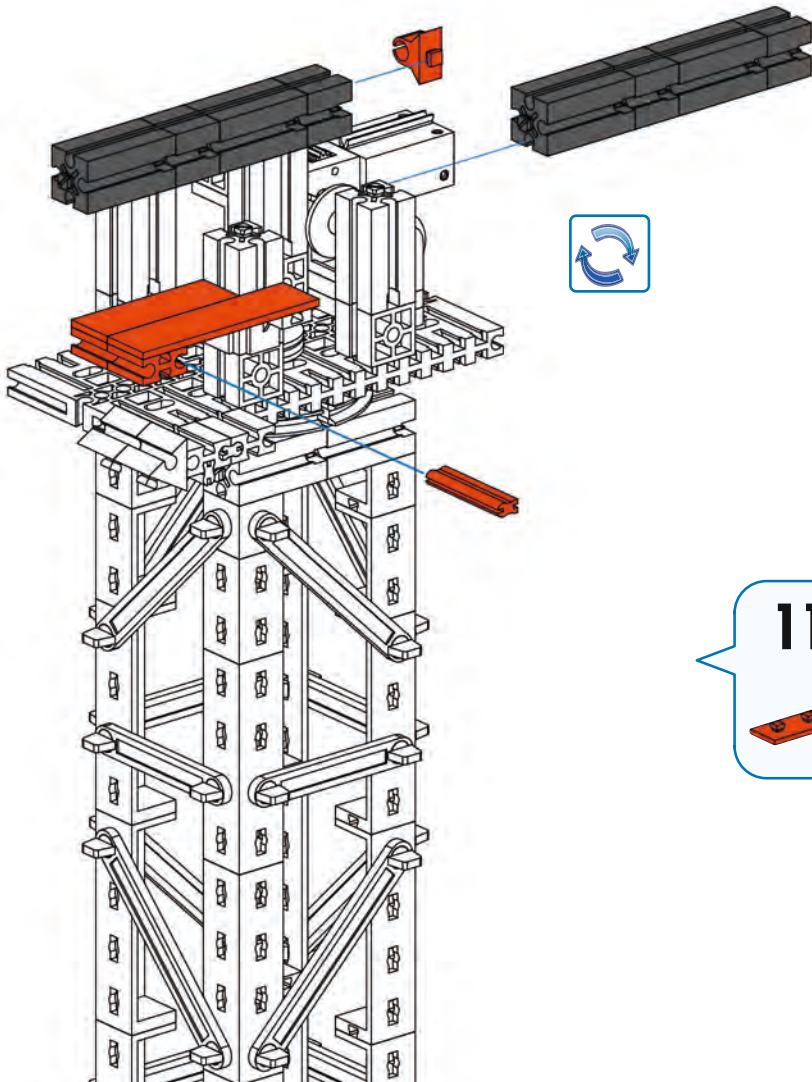







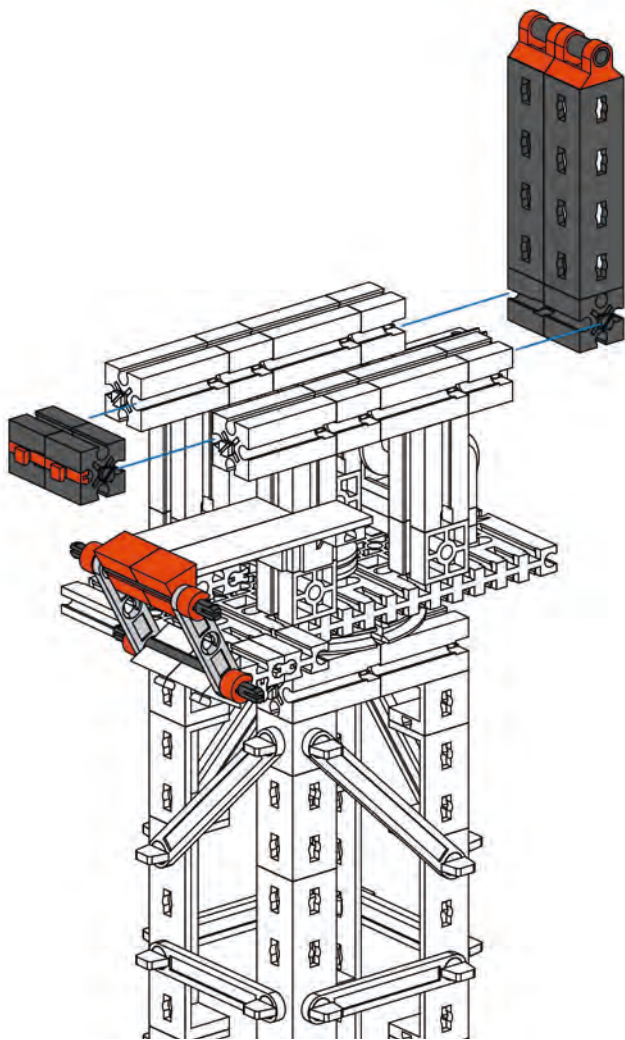

11

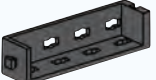







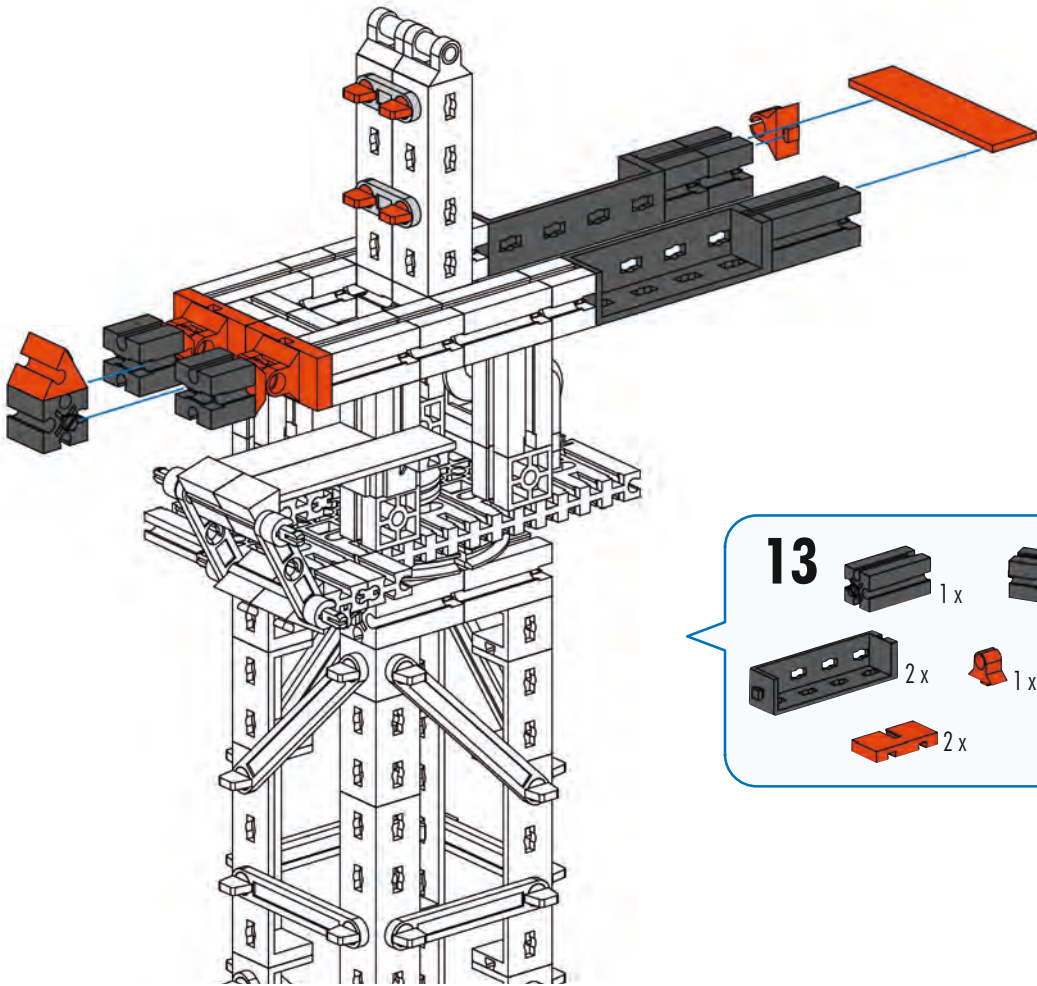
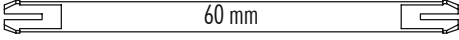







- 12**
-  2 x
  -  2 x
  -  2 x
  -  2 x
  -  2 x
  -  2 x
  -  2 x
  -  4 x



- 13**
-  1 x
  -  4 x
  -  1 x
  -  1 x
  -  2 x
  -  1 x
  -  2 x
  -  4 x
  -  2 x
  -  2 x
  -  1 x

**14**

- 120 2 x
- 90 2 x
- 2 x
- A 4 x
- 2 x

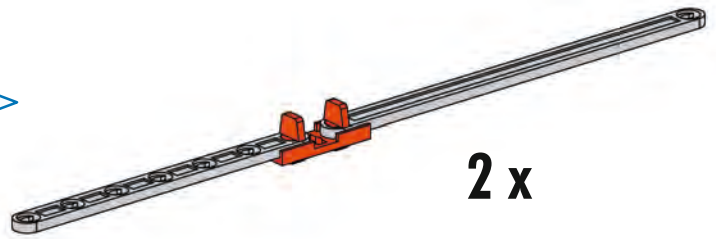



**15**

- 2 x
- 2 x
- 2 x
- A 4 x
- 2 x
- 60 1 x
- 106 2 x
- 2 x
- 2 x

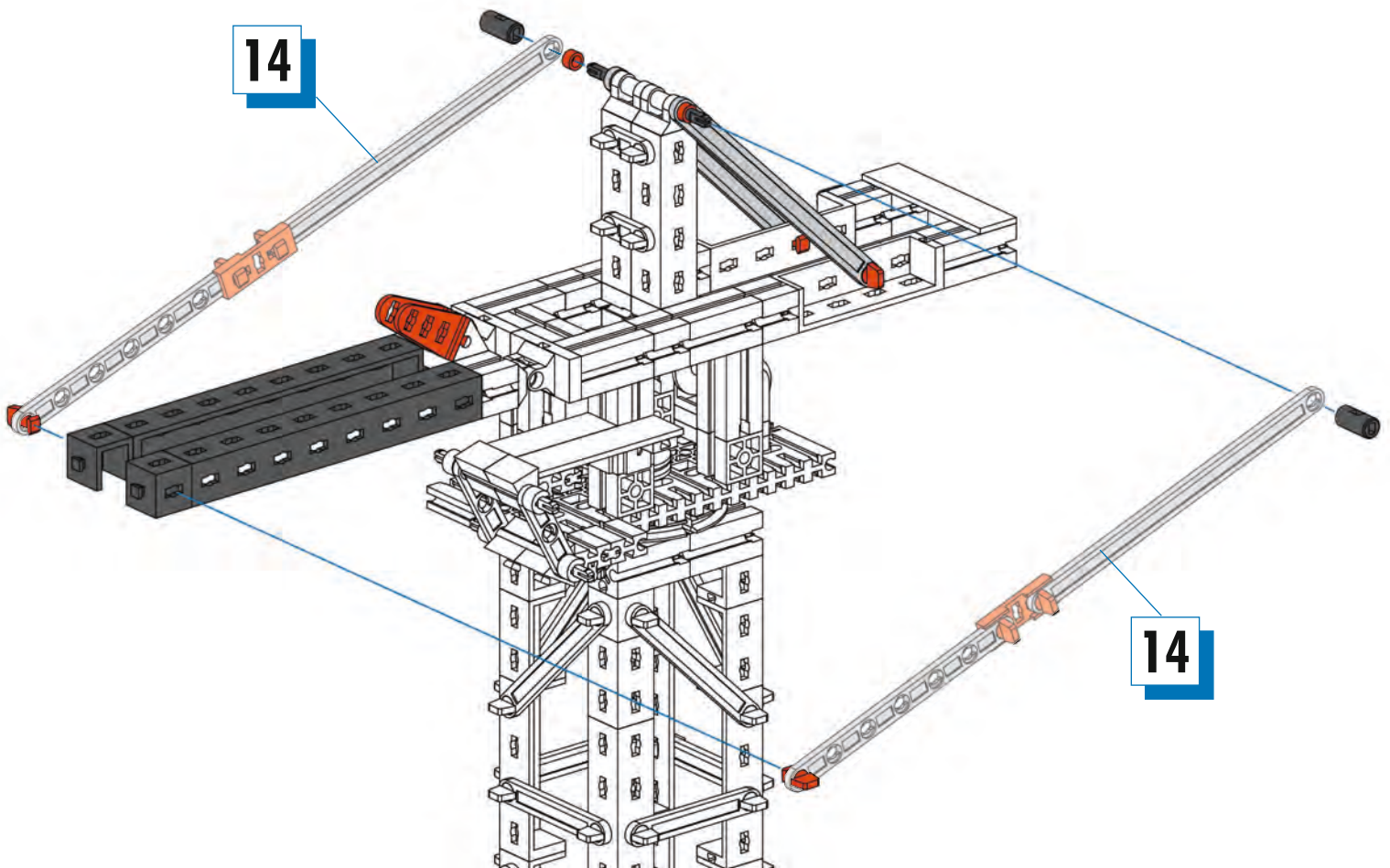

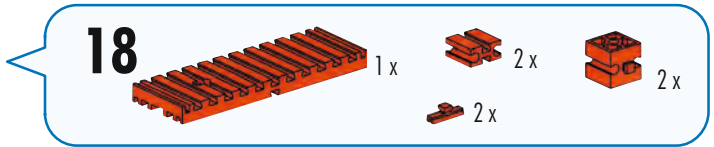
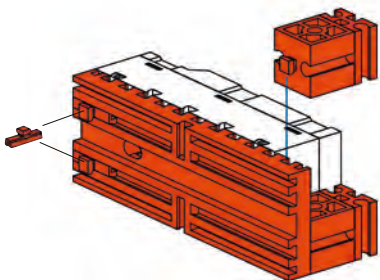
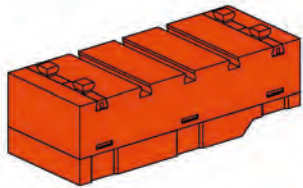
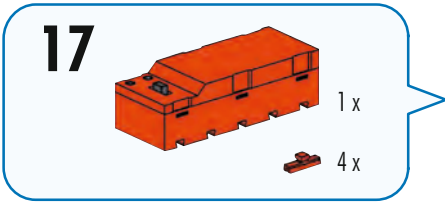
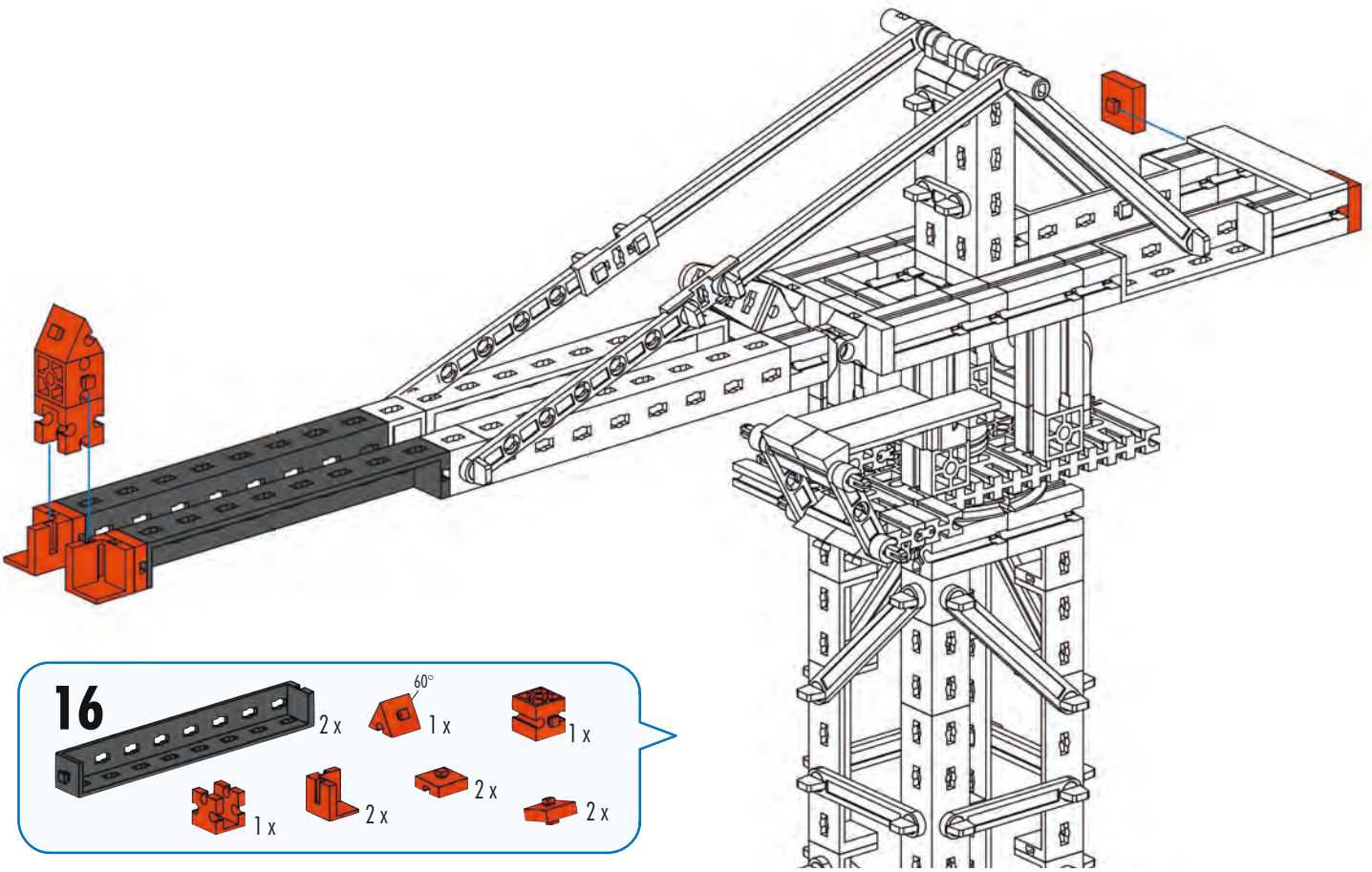

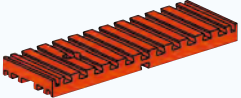
60 mm



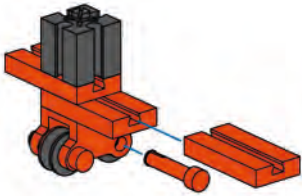
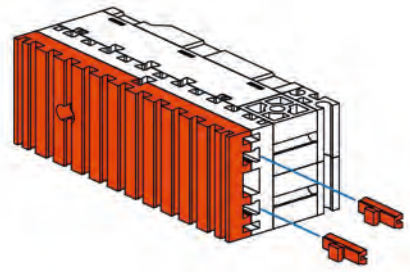





**19**  1x  2x

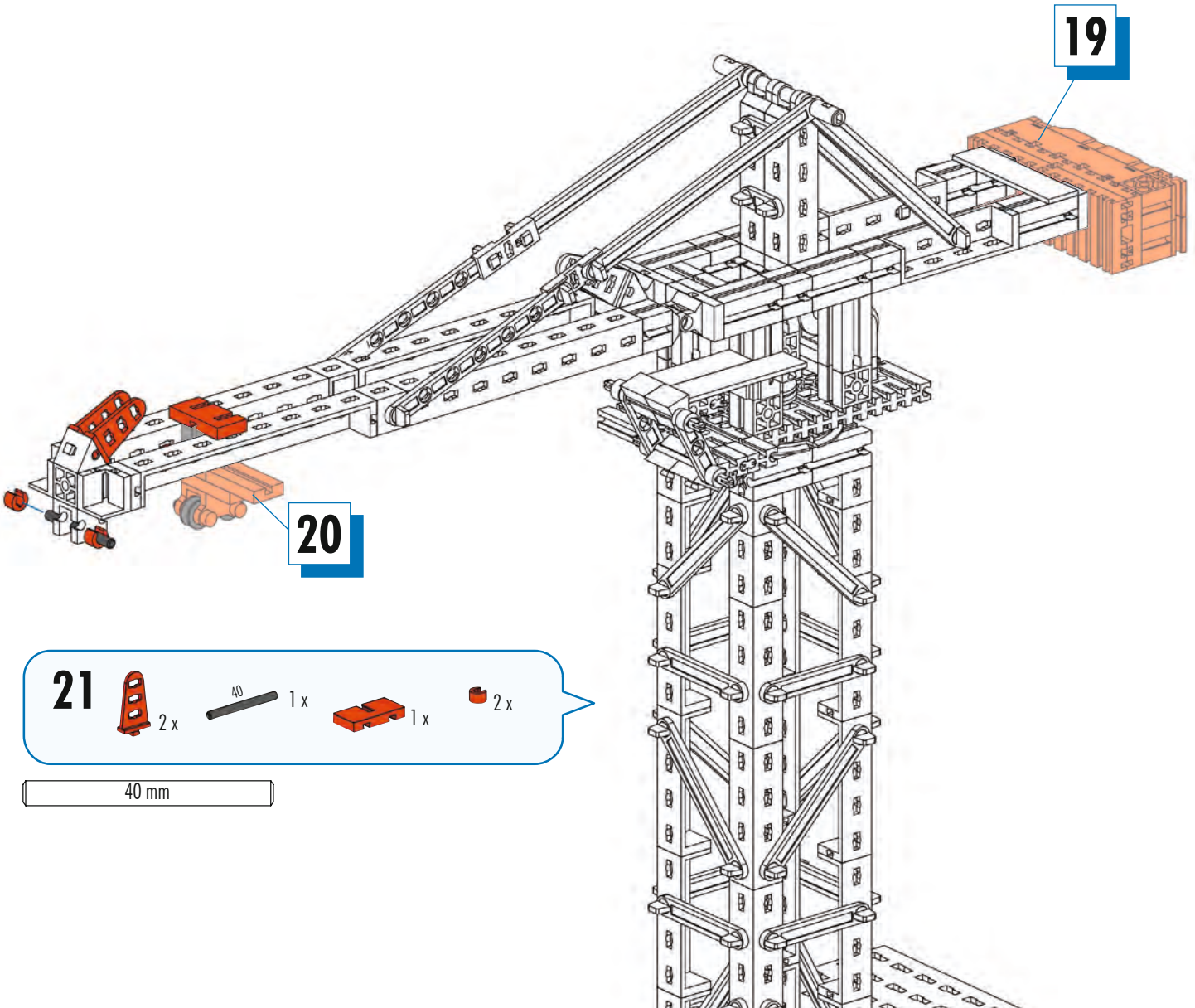

**20**  1x  3x  1x  2x  2x



**21**  2x  40 1x  1x  2x

40 mm

2 x

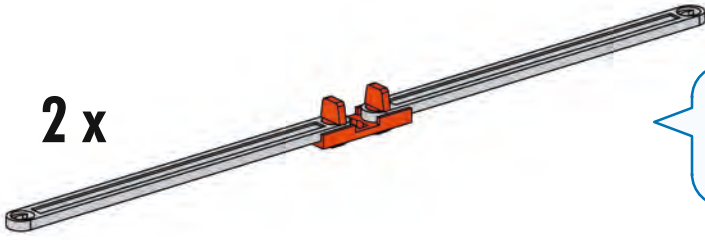

22



23



22

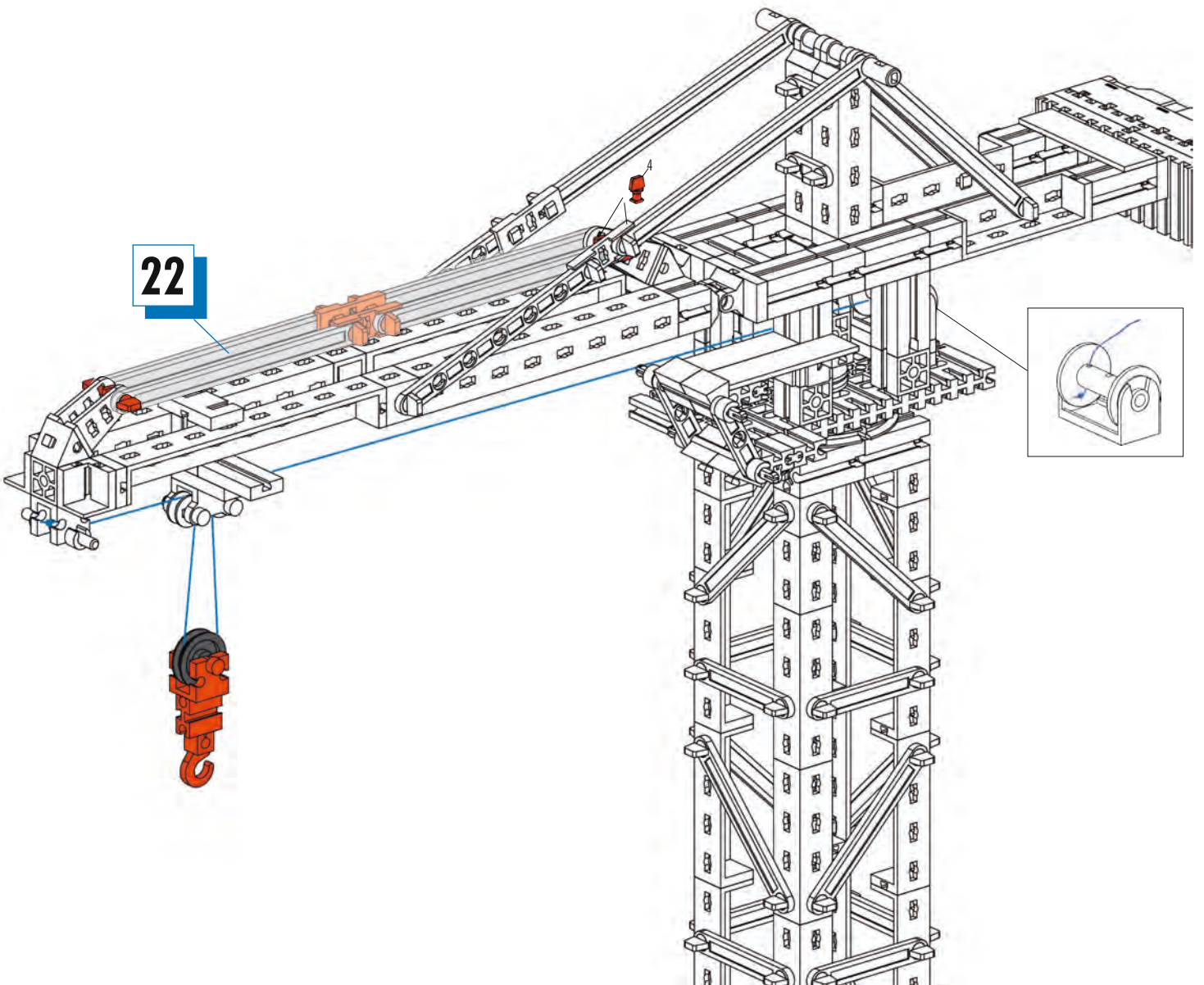

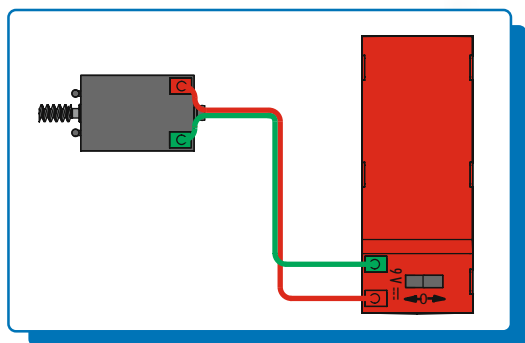
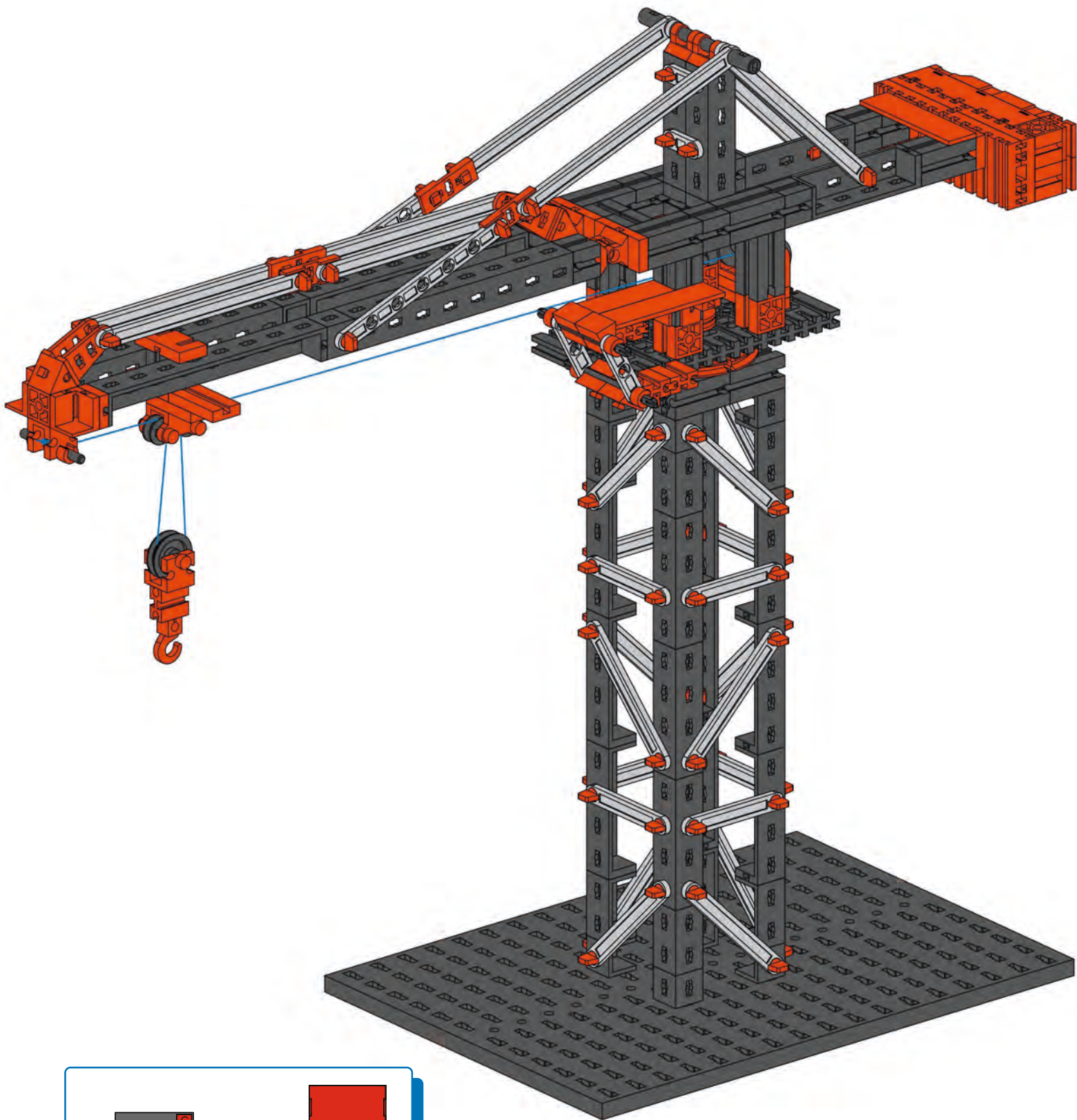

Empfohlene Aufbewahrung:	4 x Aufbewahrungssystem Art.-Nr. 94828
Recommended storage:	4 x storage system Art No. 94828
Stockage conseillé :	4 x système de stockage Art n° 94828
Bewaaraadvies:	4 x bewaarsysteem art.-nr. 94828
Consejos para guardar el producto:	4 x almacenamiento Art. N° 94828
Conservação recomendada:	4 x sistema de conservação n.º de art. 94828
Conservazione consigliata:	4 sistemi di conservazione, cod. prod. 94828
Рекомендуемое хранение:	4 x бокса для хранения. Арт.№ 94 828
推荐的保存方式 :	4个产品号为 94 828 的保存系统

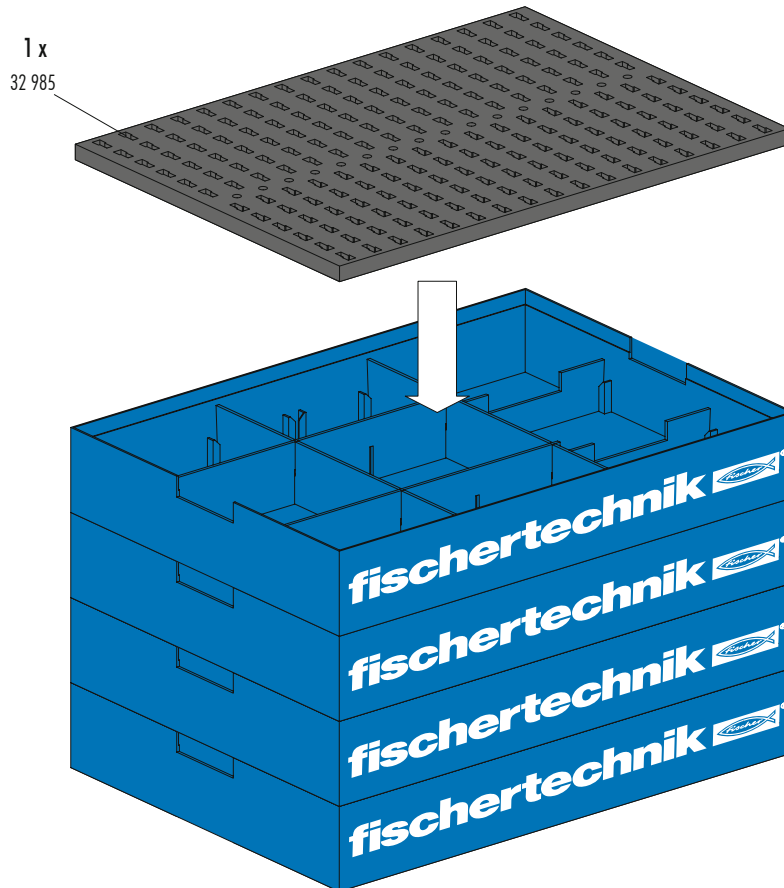

Sortiervorschlag / Storage suggestion / Suggestion de classement / Sorteervoorstel / Propuesta de clasificación / Proposta de divisão / Proposta di sistemazione / Рекомендации по сортировке / 保存系统的分类建议:

[www.fischertechnik.de/Sortiervorschläge](http://www.fischertechnik.de/Sortiervorschläge)



Hinweise zum Umweltschutz / Instructions for Environmental Protection / Remarques de protection de l'environnement / Bescherming van het milieu / Notas con respecto a la protección del medio ambiente / Instruções para a proteção do meio ambiente / Indicazioni sulla tutela ambientale / Указания по охране окружающей среды / 有关环保的提示 :

[www.fischertechnik.de/environment](http://www.fischertechnik.de/environment)